



US 20190051860A1

(19) **United States**

(12) **Patent Application Publication**
Jeong et al.

(10) **Pub. No.: US 2019/0051860 A1**
(43) **Pub. Date: Feb. 14, 2019**

(54) **ORGANIC LIGHT-EMITTING DISPLAY APPARATUS**

Publication Classification

(71) Applicant: **Samsung Display Co., Ltd.**, Yongin-si (KR)

(51) **Int. Cl.**
H01L 51/52 (2006.01)
H01L 27/32 (2006.01)
H01L 51/00 (2006.01)
C07D 221/14 (2006.01)
C07D 401/10 (2006.01)

(72) Inventors: **Eunjae Jeong**, Yongin-si (KR);
Youngkook Kim, Yongin-si (KR);
Yohan Kim, Yongin-si (KR); **Esu Kim**,
Yongin-si (KR); **Jongwoo Kim**,
Yongin-si (KR); **Jangyeol Baek**,
Yongin-si (KR); **Wonmin Yun**,
Yongin-si (KR); **Sanghyun Han**,
Yongin-si (KR); **Seokhwan Hwang**,
Yongin-si (KR)

(52) **U.S. Cl.**
CPC *H01L 51/5253* (2013.01); *H01L 27/3244*
(2013.01); *H01L 27/322* (2013.01); *C07D*
401/10 (2013.01); *H01L 51/0067* (2013.01);
C07D 221/14 (2013.01); *H01L 51/0072*
(2013.01)

(21) Appl. No.: **15/973,289**

(57) **ABSTRACT**

(22) Filed: **May 7, 2018**

An organic light-emitting display apparatus includes a substrate, an organic light-emitting device disposed above the substrate, and an encapsulation unit disposed above the organic light-emitting device and sealing the organic light-emitting device, wherein the encapsulation unit includes a compound represented by Formula 1.

(30) **Foreign Application Priority Data**

Aug. 9, 2017 (KR) 10-2017-0101347

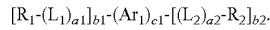

Formula 1

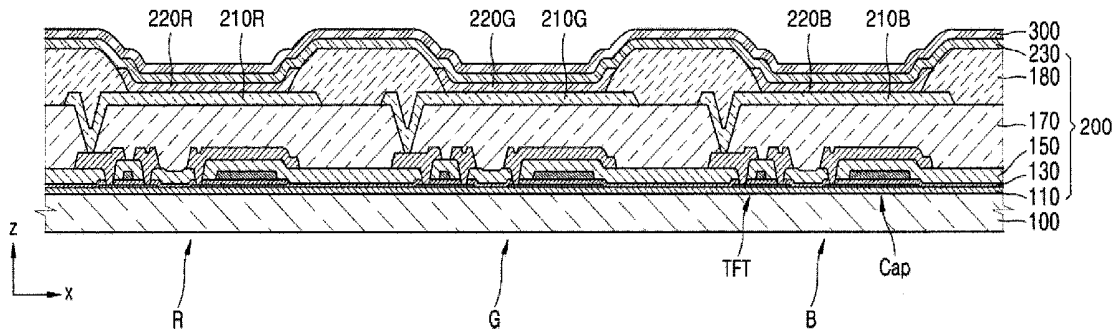

FIG. 1

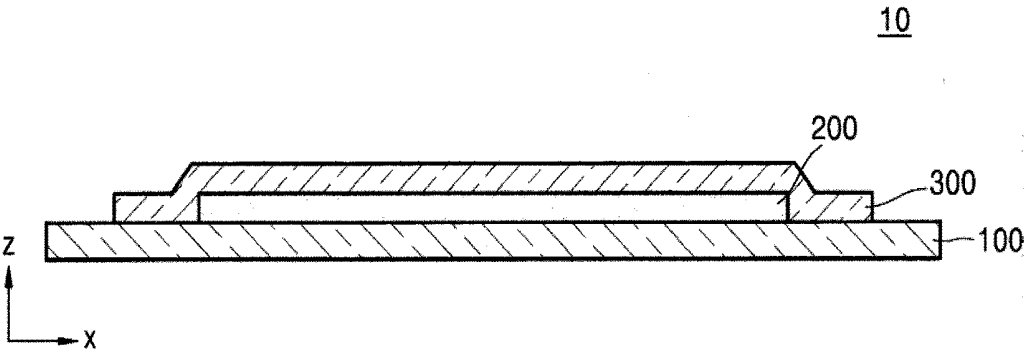
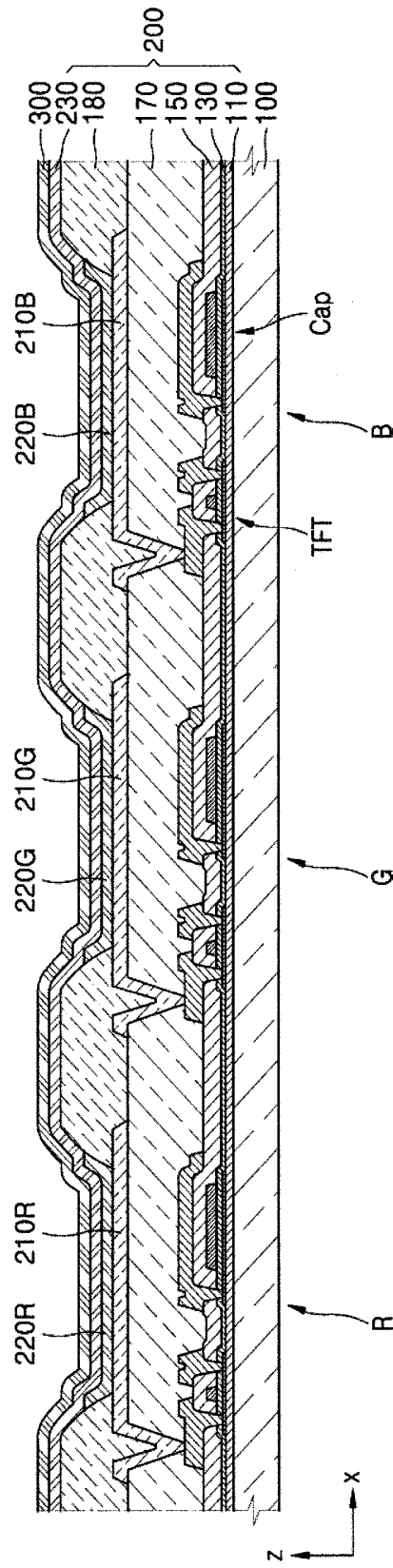

FIG. 2



ORGANIC LIGHT-EMITTING DISPLAY APPARATUS

CROSS-REFERENCE TO RELATED APPLICATION

[0001] This application claims priority to and the benefit of Korean Patent Application No. 10-2017-0101347, filed on Aug. 9, 2017, in the Korean Intellectual Property Office, the disclosure of which is incorporated herein in its entirety by reference.

BACKGROUND

1. Field

[0002] One or more embodiments relate to an organic light-emitting display apparatus.

2. Description of the Related Art

[0003] An organic light-emitting display apparatus is a self-emission device and includes an organic light-emitting device, which includes a hole injection electrode, an electron injection electrode, and an organic emission layer between the hole injection electrode and the electron injection. Holes provided from the hole injection electrode and electrons provided from the electron injection electrode recombine in the organic emission layer to produce excitons. These excitons transit from an excited state to a ground state, thereby generating light.

[0004] Because the organic light-emitting display apparatus, which is a self-emission device, does not require a separate light source, the organic light-emitting display apparatus may be driven at a low voltage and configured to be lightweight and thin. Also, because of excellent characteristics in terms of a viewing angle, contrast, response time, and/or the like, the applications of the organic light-emitting display apparatus have expanded from personal portable devices (such as MP3 players or mobile phones) to televisions.

[0005] However, if ultraviolet rays or the like are introduced from the outside into the organic light-emitting display apparatus, or if ultraviolet rays are introduced in the process of manufacturing the organic light-emitting display apparatus and penetrate into the organic light-emitting display apparatus, an emission layer, an insulating film, and/or the like including an organic material may be particularly seriously damaged.

SUMMARY

[0006] Aspects of the present disclosure are directed toward an organic light-emitting display apparatus capable of reducing an amount of ultraviolet rays transmitting through the organic light-emitting display apparatus.

[0007] Additional aspects will be set forth in part in the description which follows and, in part, will be apparent from the description, or may be learned by practice of the presented embodiments.

[0008] According to an embodiment of the present disclosure, an organic light-emitting display apparatus includes:

[0009] a substrate;

[0010] an organic light-emitting device on the substrate; and

[0011] an encapsulation unit on the organic light-emitting device and configured to seal the organic light-emitting device,

[0012] wherein the encapsulation unit includes a first compound represented by Formula 1:

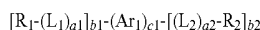

Formula 1

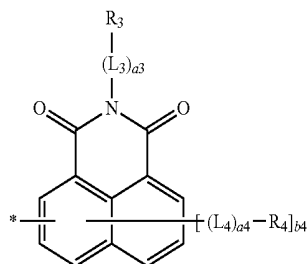

Formula 2-1

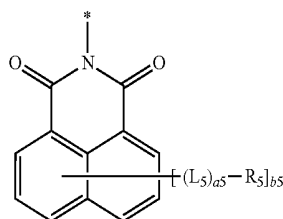

Formula 2-2

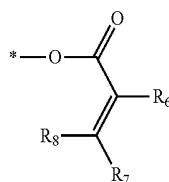

Formula 2-4

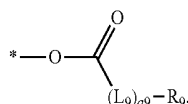

Formula 2-3

[0013] In Formulae 1 and 2-1 to 2-4,

[0014] An may be a C₅-C₆₀ carbocyclic group or a C₂-C₃₀ heterocyclic group,

[0015] c1 may be 0 or 1,

[0016] L₁ to L₅ and L₉ may each independently be selected from *—N(R₁₁)—*, *—B(R₁₁)—*, *—P(R₁₁)—*, *—Si(R₁₁)(R₁₂)—*, *—S—*, *—Se—*, *—O—*, *—C(=O)—*, *—S(=O)—*, *—S(=O)₂—*, *—C(R₁₁)=*, *—C(=S)—*, a substituted or unsubstituted C₁-C₆₀ alkylene group, a substituted or unsubstituted C₂-C₆₀ alkenylene group, a substituted or unsubstituted C₂-C₆₀ alkyne group, a substituted or unsubstituted C₃-C₁₀ cycloalkylene group, a substituted or unsubstituted C₁-C₁₀ heterocycloalkylene group, a substituted or unsubstituted C₃-C₁₀ cycloalkenylene group, a substituted or unsubstituted C₁-C₁₀ heterocycloalkenylene group, a substituted or unsubstituted C₆-C₆₀ arylene group, a substituted or unsubstituted C₁-C₆₀ heteroarylene group, a substituted or unsubstituted divalent non-aromatic condensed polycyclic group, and a substituted or unsubstituted divalent non-aromatic condensed heteropolycyclic group,

[0017] a1 to a5 and a9 may each independently be an integer from 0 to 10,

[0018] R_1 may be a group represented by Formula 2-1 or a group represented by Formula 2-2,

[0019] R_2 to R_5 may each independently be selected from a group represented by Formula 2-3, a group represented by Formula 2-4, hydrogen, deuterium, —F, —Cl, —Br, —I, a hydroxyl group, a cyano group, a nitro group, an amidino group, a hydrazino group, a hydrazono group, a substituted or unsubstituted C_1 - C_{60} alkyl group, a substituted or unsubstituted C_2 - C_{60} alkenyl group, a substituted or unsubstituted C_2 - C_{60} alkynyl group, a substituted or unsubstituted C_1 - C_{60} alkoxy group, a substituted or unsubstituted C_3 - C_{60} cycloalkoxy group, a substituted or unsubstituted C_3 - C_{10} cycloalkyl group, a substituted or unsubstituted C_1 - C_{10} heterocycloalkyl group, a substituted or unsubstituted C_3 - C_{10} cycloalkenyl group, a substituted or unsubstituted heterocycloalkenyl group, a substituted or unsubstituted C_6 - C_{60} aryl group, a substituted or unsubstituted C_6 - C_{60} aryloxy group, a substituted or unsubstituted C_6 - C_{60} arylthio group, a substituted or unsubstituted C_1 - C_{60} heteroaryl group, a substituted or unsubstituted monovalent non-aromatic condensed polycyclic group, a substituted or unsubstituted monovalent non-aromatic condensed heteropolycyclic group, $Si(Q_1)(Q_2)(Q_3)$, — $N(Q_1)(Q_2)$, — $B(Q_1)(Q_2)$, — $C(=O)(Q_1)$, — $S(=O)_2(Q_1)$, and — $P(=O)(Q_1)(Q_2)$,

[0020] R_6 to R_9 , R_{11} , and R_{12} may each independently be selected from hydrogen, deuterium, —F, —Cl, —Br, —I, a hydroxyl group, a cyano group, a nitro group, an amidino group, a hydrazino group, a hydrazono group, a substituted or unsubstituted C_1 - C_{60} alkyl group, a substituted or unsubstituted C_2 - C_{60} alkenyl group, a substituted or unsubstituted C_2 - C_{60} alkynyl group, a substituted or unsubstituted C_1 - C_{60} alkoxy group, a substituted or unsubstituted C_3 - C_{60} cycloalkoxy group, a substituted or unsubstituted C_3 - C_{10} cycloalkyl group, a substituted or unsubstituted C_1 - C_{10} heterocycloalkyl group, a substituted or unsubstituted C_3 - C_{10} cycloalkenyl group, a substituted or unsubstituted C_1 - C_{10} heterocycloalkenyl group, a substituted or unsubstituted C_6 - C_{60} aryl group, a substituted or unsubstituted C_6 - C_{60} aryloxy group, a substituted or unsubstituted C_6 - C_{60} arylthio group, a substituted or unsubstituted C_1 - C_{60} heteroaryl group, a substituted or unsubstituted monovalent non-aromatic condensed polycyclic group, a substituted or unsubstituted monovalent non-aromatic condensed heteropolycyclic group, $Si(Q_4)(Q_5)(Q_6)$, — $N(Q_4)(Q_5)$, — $B(Q_4)(Q_5)$, — $C(=O)(Q_4)$, — $S(=O)_2(Q_4)$, and — $P(=O)(Q_4)(Q_5)$,

[0021] b_1 may be an integer from 1 to 10, wherein, when b_1 is two or more, two or more $*(L_1)_{a1}$ - $R_1(s)$ may be identical to or different from each other,

[0022] b_2 may be an integer from 1 to 10, wherein, when b_2 is two or more, two or more $*(L_2)_{a2}$ - $R_2(s)$ may be identical to or different from each other,

[0023] b_4 may be an integer from 0 to 5, wherein, when b_4 is two or more, two or more $*(L_4)_{a4}$ - $R_4(s)$ may be identical to or different from each other,

[0024] b_5 may be an integer from 0 to 6, wherein, when b_5 is two or more, two or more $*(L_5)_{a5}$ - $R_5(s)$ may be identical to or different from each other,

[0025] at least one substituent of the substituted C_1 - C_{60} alkylene group, the substituted C_2 - C_{60} alkenylene group, the substituted C_2 - C_{60} alkynylene group, the substituted C_3 - C_{10} cycloalkylene group, the substituted C_1 - C_{10} heterocycloalkylene group, the substituted C_3 - C_{10} cycloalkenylene group, the substituted C_1 - C_{10} heterocycloalkenylene group,

the substituted C_6 - C_{60} arylene group, the substituted C_1 - C_{60} heteroarylene group, the substituted divalent non-aromatic condensed polycyclic group, the substituted divalent non-aromatic condensed heteropolycyclic group, the substituted C_1 - C_{60} alkyl group, the substituted C_2 - C_{60} alkenyl group, the substituted C_2 - C_{60} alkynyl group, the substituted C_1 - C_{60} alkoxy group, the substituted C_3 - C_{60} cycloalkoxy group, the substituted C_3 - C_{10} cycloalkyl group, the substituted C_1 - C_{10} heterocycloalkyl group, the substituted C_3 - C_{10} cycloalkenyl group, the substituted C_1 - C_{10} heterocycloalkenyl group, the substituted C_6 - C_{60} aryl group, the substituted C_6 - C_{60} aryloxy group, the substituted C_6 - C_{60} arylthio group, the substituted C_1 - C_{60} heteroaryl group, the substituted monovalent non-aromatic condensed polycyclic group, and the substituted monovalent non-aromatic condensed heteropolycyclic group may be selected from:

[0026] deuterium, —F, —Cl, —Br, —I, a hydroxyl group, a cyano group, a nitro group, an amidino group, a hydrazino group, a hydrazono group, a C_1 - C_{60} alkyl group, a C_2 - C_{60} alkenyl group, a C_2 - C_{60} alkynyl group, a C_1 - C_{60} alkoxy group, and a C_3 - C_{60} cycloalkoxy group;

[0027] a C_1 - C_{60} alkyl group, a C_2 - C_{60} alkenyl group, a C_2 - C_{60} alkynyl group, a C_1 - C_{60} alkoxy group, and a C_3 - C_{60} cycloalkoxy group, each substituted with at least one selected from deuterium, —F, —Cl, —Br, —I, a hydroxyl group, a cyano group, a nitro group, an amidino group, a hydrazino group, a hydrazono group, a C_3 - C_{10} cycloalkyl group, a C_1 - C_{10} heterocycloalkyl group, a C_3 - C_{10} cycloalkenyl group, a C_1 - C_{10} heterocycloalkenyl group, a C_6 - C_{60} aryl group, a C_6 - C_{60} aryloxy group, a C_6 - C_{60} arylthio group, a C_1 - C_{60} heteroaryl group, a monovalent non-aromatic condensed polycyclic group, a monovalent non-aromatic condensed heteropolycyclic group, — $Si(Q_{11})(Q_{12})(Q_{13})$, — $N(Q_{11})(Q_{12})$, — $B(Q_{11})(Q_{12})$, — $C(=O)(Q_{11})$, — $S(=O)_2(Q_{11})$, and — $P(=O)(Q_{11})(Q_{12})$;

[0028] a C_3 - C_{10} cycloalkyl group, a C_1 - C_{10} heterocycloalkyl group, a C_3 - C_{10} cycloalkenyl group, a C_1 - C_{10} heterocycloalkenyl group, a C_6 - C_{60} aryl group, a C_6 - C_{60} aryloxy group, a C_6 - C_{60} arylthio group, a C_1 - C_{60} heteroaryl group, a monovalent non-aromatic condensed polycyclic group, a monovalent non-aromatic condensed heteropolycyclic group, a biphenyl group, and a terphenyl group;

[0029] a C_3 - C_{10} cycloalkyl group, a C_1 - C_{10} heterocycloalkyl group, a C_3 - C_{10} cycloalkenyl group, a C_1 - C_{10} heterocycloalkenyl group, a C_6 - C_{60} aryl group, a C_6 - C_{60} aryloxy group, a C_6 - C_{60} arylthio group, a C_1 - C_{60} heteroaryl group, a monovalent non-aromatic condensed polycyclic group, a monovalent non-aromatic condensed heteropolycyclic group, each substituted with at least one selected from deuterium, —F, —Cl, —Br, —I, a hydroxyl group, a cyano group, a nitro group, an amidino group, a hydrazino group, a hydrazono group, a C_1 - C_{60} alkyl group, a C_2 - C_{60} alkenyl group, a C_2 - C_{60} alkynyl group, a C_1 - C_{60} alkoxy group, a C_3 - C_{60} cycloalkoxy group, a C_3 - C_{10} cycloalkyl group, a C_1 - C_{10} heterocycloalkyl group, a C_3 - C_{10} cycloalkenyl group, a C_1 - C_{10} heterocycloalkenyl group, a C_6 - C_{60} aryl group, a C_6 - C_{60} aryloxy group, a C_6 - C_{60} arylthio group, a C_1 - C_{60} heteroaryl group, a monovalent non-aromatic condensed polycyclic group, a monovalent non-aromatic condensed heteropolycyclic group, — $Si(Q_{21})(Q_{22})(Q_{23})$, — $N(Q_{21})(Q_{22})$, — $B(Q_{21})(Q_{22})$, — $C(=O)(Q_{21})$, — $S(=O)_2(Q_{21})$, and — $P(=O)(Q_{21})(Q_{22})$; and

[0030] $-\text{Si}(\text{Q}_{31})(\text{Q}_{32})(\text{Q}_{33})$, $-\text{N}(\text{Q}_{31})(\text{Q}_{32})$, $-\text{B}(\text{Q}_{31})(\text{Q}_{32})$, $-\text{C}(=\text{O})(\text{Q}_{31})$, $-\text{S}(=\text{O})_2(\text{Q}_{31})$, and $-\text{P}(=\text{O})(\text{Q}_{31})(\text{Q}_{32})$.

[0031] Q_1 to Q_6 , Q_{11} to Q_{13} , Q_{21} to Q_{23} , and Q_{31} to Q_{33} may each independently be selected from hydrogen, deuterium, $-\text{F}$, $-\text{Cl}$, $-\text{Br}$, $-\text{I}$, a hydroxyl group, a cyano group, a nitro group, an amidino group, a hydrazino group, a hydrazono group, a C_1 - C_{60} alkyl group, a C_2 - C_{60} alkenyl group, a C_2 - C_{60} alkynyl group, a C_1 - C_{60} alkoxy group, a C_3 - C_{60} cycloalkoxy group, a C_3 - C_{10} cycloalkyl group, a C_1 - C_{10} heterocycloalkyl group, a C_3 - C_{10} cycloalkenyl group, a C_1 - C_{10} heterocycloalkenyl group, a C_6 - C_{60} aryl group, a C_6 - C_{60} aryl group substituted with a C_1 - C_{60} alkyl group, a C_6 - C_{60} aryl group substituted with a C_6 - C_{60} aryl group, a terphenyl group, a C_1 - C_{60} heteroaryl group, a C_1 - C_{60} heteroaryl group substituted with a C_1 - C_{60} alkyl group, a C_1 - C_{60} heteroaryl group substituted with a C_6 - C_{60} aryl group, a monovalent non-aromatic condensed polycyclic group, a monovalent non-aromatic condensed heteropolycyclic group, a biphenyl group, and a terphenyl group, and

[0032] * and *' each indicate a binding site to a neighboring atom.

[0033] According to another embodiment, an organic light-emitting display apparatus includes:

[0034] a substrate;

[0035] an organic emission unit on the substrate and including a plurality of organic light-emitting devices; and

[0036] an encapsulation unit on the organic emission unit and sealing the organic emission unit,

[0037] wherein the encapsulation unit includes a first compound represented by Formula 1.

BRIEF DESCRIPTION OF THE DRAWINGS

[0038] These and/or other aspects will become apparent and more readily appreciated from the following description of the embodiments, taken in conjunction with the accompanying drawings in which:

[0039] FIG. 1 is a schematic cross-sectional view of an organic light-emitting display apparatus according to an embodiment; and

[0040] FIG. 2 is a schematic cross-sectional view of an organic light-emitting display apparatus according to another embodiment.

DETAILED DESCRIPTION

[0041] The present disclosure will now be described more fully with reference to exemplary embodiments. The disclosure may, however, be embodied in many different forms and should not be construed as being limited to the embodiments set forth herein; rather, these embodiments are provided so that this disclosure will be thorough and complete, and will fully convey the concept of the disclosure to those skilled in the art. Enhancements and features of the present invention and how to achieve them will become apparent by reference to the embodiment that will be described later in more detail, together with the accompanying drawings. This invention may, however, be embodied in many different forms and should not be limited to the exemplary embodiments.

[0042] Hereinafter, embodiments are described in more detail by referring to the accompanying drawings. In the drawings, like reference numerals denote like elements, and a redundant explanation thereof will not be provided herein.

[0043] It will be understood that when a layer, film, region, or plate is referred to as being “formed on” another layer, film, region, or plate, it can be directly or indirectly formed on the other layer, film, region, or plate. That is, for example, intervening layers, films, regions, or plates may be present. In addition, sizes of components in the drawings may be exaggerated for convenience of explanation. In other words, because sizes and thicknesses of components in the drawings are arbitrarily illustrated for convenience of explanation, the following embodiments of the present disclosure are not limited thereto. .

[0044] Hereinafter, the terms “first, second, etc.,” are used only for the purpose of distinguishing one element from another.

[0045] In the following Examples, the x-axis and the z-axis are not limited to two axes on the rectangular coordinate system, and may be interpreted in a broader sense. For example, the x-axis and the z-axis may cross each other at right angles, but they may also refer to different directions that the axes do not cross each other at right angles.

[0046] FIG. 1 is a schematic cross-sectional view of an organic light-emitting display apparatus according to an embodiment.

[0047] In FIG. 1, an organic light-emitting display apparatus according to an embodiment includes a substrate **100**, an organic light-emitting device **200**, and an encapsulation unit **300**.

[0048] The substrate **100** may be any one of various suitable substrates that are utilized in an organic light-emitting display apparatus in the related art, and may be an inorganic substrate or an organic substrate, each having high mechanical strength, thermal stability, transparency, surface smoothness, ease of handling, and/or water repellency.

[0049] For example, the substrate may be an inorganic substrate made of a transparent glass material including SiO_2 as a main component, but embodiments of the present disclosure are not limited thereto.

[0050] In one or more embodiments, the substrate may be an organic substrate having an insulating property. An organic material having the insulating property may be selected from, for example, polyethersulphone (PES), polyacrylate (PAR), polyetherimide (PEI), polyethylenenaphthalate (PEN), polyethyleneterephthalate (PET), polyphenylene sulfide (PPS), polyallylate, polyimide, polycarbonate (PC), cellulose triacetate (TAC), and cellulose acetate propionate (CAP), but embodiments of the present disclosure are not limited thereto.

[0051] The organic light-emitting device **200** is disposed on the substrate **100**. The organic light-emitting device **200** may include a first electrode, an intermediate layer including an emission layer, and a second electrode.

[0052] The first electrode may be formed by, for example, depositing or sputtering a material for forming the first electrode on the substrate. When the first electrode is an anode, the material for forming the first electrode may be selected from materials with a high work function to facilitate hole injection.

[0053] The first electrode may be a reflective electrode, a semi-transmissive electrode, or a transmissive electrode. When the first electrode is a transmissive electrode, a material for forming the first electrode may be selected from indium tin oxide (ITO), indium zinc oxide (IZO), tin oxide (SnO_2), zinc oxide (ZnO), and any combinations thereof, but embodiments of the present disclosure are not limited

thereto. In one or more embodiments, when the first electrode is a semi-transmissive electrode or a reflective electrode, a material for forming the first electrode may be selected from magnesium (Mg), silver (Ag), aluminum (Al), aluminum-lithium (Al—Li), calcium (Ca), magnesium-indium (Mg—In), magnesium-silver (Mg—Ag), and any combinations thereof, but embodiments of the present disclosure are not limited thereto.

[0054] The first electrode may have a single-layered structure, or a multi-layered structure including two or more layers. For example, the first electrode may have a three-layered structure of ITO/Ag/ITO, but the structure of the first electrode is not limited thereto.

[0055] On the first electrode, an interlayer including an emission layer may be disposed.

[0056] The interlayer may further include a hole transport region between the first electrode and the emission layer, and an electron transport region between the emission layer and the second electrode.

[0057] On the interlayer, the second electrode may be disposed. The second electrode may be a cathode that is an electron injection electrode, and in this regard, a metal for forming the second electrode may be a material having a low work function, such as a metal, an alloy, an electrically conductive compound, or a mixture thereof.

[0058] The second electrode may include at least one selected from lithium (Li), silver (Ag), magnesium (Mg), aluminum (Al), aluminum-lithium (Al—Li), calcium (Ca), magnesium-indium (Mg—In), magnesium-silver (Mg—Ag), ITO, and IZO, but embodiments of the present disclosure are not limited thereto. The second electrode may be a transmissive electrode, a semi-transmissive electrode, or a reflective electrode.

[0059] The first electrode may have a single-layered structure, or a multi-layered structure including two or more layers.

[0060] On the organic light-emitting device 200, the encapsulation unit 300 may be disposed.

[0061] The encapsulation unit 300 may include a first compound represented by Formula 1 below:

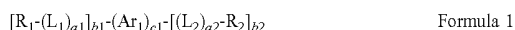

[0062] In Formula 1, Ar₁ may be a C₅-C₆₀ carbocyclic group or a C₂-C₃₀ heterocyclic group.

[0063] For example, Ar₁ may be selected from a benzene group, a naphthalene group, an anthracene group, a phenanthrene group, a pyrene group, a chrysene group, a triphenylene group, an indene group, a fluorene group, a benzo-fluorene group, a spiro-bifluorene group, a carbazole group, a dibenzofuran group, a dibenzothiophene group, a pyridine group, a pyrazine group, a pyrimidine group, a pyridazine group, a pyrrole group, an imidazole group, a quinoline group, an isoquinoline group, a quinoxaline group, a quinazoline group, a triazine group, an indeno pyrazine group, an indeno pyridine group, a phenanthroline group, and a phenanthridine group.

[0064] In one embodiment, An may be selected from a benzene group, a naphthalene group, an anthracene group, a fluorene group, a spiro-bifluorene group, a carbazole group, a dibenzofuran group, a dibenzothiophene group, a pyridine group, a pyrazine group, a pyrimidine group, a pyridazine group, and a triazine group.

[0065] In one or more embodiments, Ar₁ may be selected from a benzene group, a naphthalene group, an anthracene

group, a dibenzofuran group, a dibenzothiophene group, a pyridine group, and a triazine group, but embodiments of the present disclosure are not limited thereto.

[0066] In Formula 1, c₁ may be 0 or 1. c₁ indicates the number of Ar₁, and when c₁ is 0, *—Ar₁—* is a single bond.

[0067] In Formula 1, R₁ may be a group represented by Formula 2-1 or a group represented by Formula 2-2:

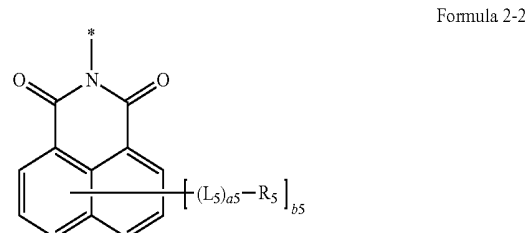
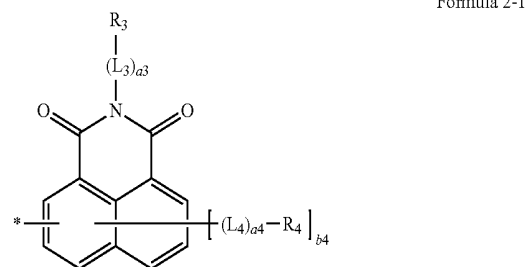

[0068] In Formulae 2-1 and 2-2, L₃ to L₅, a₃ to a₅, R₃ to R₅, b₄, and b₅ are the same as described above, and * indicates a binding site to a neighboring atom.

[0069] In Formulae 1, 2-1, and 2-2, R₂ to R₅ may each independently be selected from: a group represented by Formula 2-3, a group represented by Formula 2-4, hydrogen, deuterium, —F, —Cl, —Br, —I, a hydroxyl group, a cyano group, a nitro group, an amidino group, a hydrazino group, a hydrazono group, a substituted or unsubstituted C₁-C₆₀ alkyl group, a substituted or unsubstituted C₂-C₆₀ alkenyl group, a substituted or unsubstituted C₂-C₆₀ alkynyl group, a substituted or unsubstituted C₁-C₆₀ alkoxy group, a substituted or unsubstituted C₃-C₆₀ cycloalkoxy group, a substituted or unsubstituted C₃-C₁₀ cycloalkyl group, a substituted or unsubstituted C₁-C₁₀ heterocycloalkyl group, a substituted or unsubstituted C₃-C₁₀ cycloalkenyl group, a substituted or unsubstituted C₁-C₁₀ heterocycloalkenyl group, a substituted or unsubstituted C₆-C₆₀ aryl group, a substituted or unsubstituted C₆-C₆₀ aryloxy group, a substituted or unsubstituted C₆-C₆₀ arylthio group, a substituted or unsubstituted C₁-C₆₀ heteroaryl group, a substituted or unsubstituted monovalent non-aromatic condensed polycyclic group, a substituted or unsubstituted monovalent non-aromatic condensed heteropolycyclic group, Si(Q₁)(Q₂)(Q₃), —N(Q₁)(Q₂), —B(Q₁)(Q₂), —C(=O)(Q₁), —S(=O)₂(Q₁), and —P(=O)(Q₁)(Q₂):

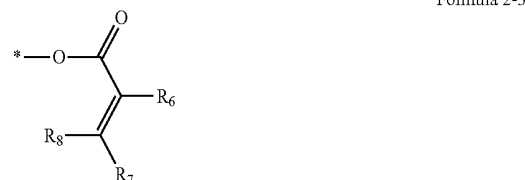

-continued

Formula 2-4

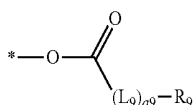

[0070] Q₁ to Q₃, L₉, a₉, and R₆ to R₉ are the same as described above, and * indicates a binding site to a neighboring atom.

[0071] In Formulae 1, 2-1, 2-2, and 2-4, L₁ to L₅ and L₉ may each independently be selected from *—N(R₁₁)—*, *—Si(R₁₁)(R₁₂)—*, *—S—*, *—Se—*, *—O—*, *—C(=O)—*, *—S(=O)—*, *—S(=O)₂—*, *—C(R₁₁)—*, *—C(=S)—*, a substituted or unsubstituted C₁-C₆₀ alkylene group, a substituted or unsubstituted C₂-C₆₀ alkenylene group, a substituted or unsubstituted C₂-C₆₀ alkynylene group, a substituted or unsubstituted C₃-C₁₀ cycloalkylene group, a substituted or unsubstituted C₁-C₁₀ heterocycloalkylene group, a substituted or unsubstituted C₃-C₁₀ cycloalkenylene group, a substituted or unsubstituted C₁-C₁₀ heterocycloalkenylene group, a substituted or unsubstituted C₆-C₆₀ arylene group, a substituted or unsubstituted C₁-C₆₀ heteroarylene group, a substituted or unsubstituted divalent non-aromatic condensed polycyclic group, and a substituted or unsubstituted divalent non-aromatic condensed heteropolycyclic group.

[0072] For example, L₁ to L₅ and L₉ may each independently be selected from:

[0073] *—S—*, *—O—*, *—C(=O)—*, *—S(=O)—*, *—S(=O)₂—*, a C₁-C₂₀ alkylene group, a C₂-C₂₀ alkenylene group, a C₂-C₂₀ alkynylene group, a phenylene group, a pentalenylene group, an indenylene group, a naphthylene group, an azulenylene group, an indacenylene group, an acenaphthylene group, a fluorenylene group, a spiro-bifluorenylene group, a spiro-benzofluorene-fluorenylene group, a benzofluorenylene group, a dibenzofluorenylene group, a phenalenylene group, a phenanthrenylene group, an anthracenylene group, a fluoranthenylene group, a triphenylenylene group, a pyrenylene group, a chrysenylene group, a perylenylene group, a pentaphenylene group, a pyrrolylene group, a thiophenylene group, a furanylene group, a silolylene group, an imidazolylene group, a pyrazolylene group, a thiazolylene group, an isothiazolylene group, an oxazolylene group, an isoxazolylene group, a pyridinylene group, a pyrazinylene group, a pyrimidinylene group, a pyridazinylene group, an indolylene group, an isoindolylene group, an indazolylene group, a purinylene group, a quinolinylene group, an isoquinolinylene group, a benzoquinolinylene group, a phthalazinylene group, a naphthyridinylene group, a quinoxalinylene group, a quinazolinylene group, a cinnolinylene group, a phenanthridinylene group, an acridinylene group, a phenanthrolinylene group, a phenazinylene group, a benzimidazolylene group, a benzofuranylene group, a benzothiofenylene group, a benzosilolylene group, an isobenzothiazolylene group, a benzoxazolylene group, an isobenzoxazolylene group, a triazolylene group, a tetrazolylene group, an oxadiazolylene group, a triazinylene group, a dibenzofuranylene group, a dibenzothiofenylene group, a dibenzosilolylene group, a carbazolylene group, a benzocarbazolylene group, a dibenzocarbazolylene group, a thiadiazolylene group, an imidazopyridinylene group, an imidazopyrimidinylene group, an oxazolopyridinylene

group, a thiazolopyridinylene group, a benzonaphthyridinylene group, an azafluorenylene group, an azaspiro-bifluorenylene group, an azacarbazolylene group, an azadibenzofuranylene group, an azadibenzothiofenylene group, and an azadibenzosilolylene group; and

[0074] a C₁-C₂₀ alkylene group, a C₂-C₂₀ alkenylene group, a C₂-C₂₀ alkynylene group, a phenylene group, a pentalenylene group, an indenylene group, a naphthylene group, an azulenylene group, an indacenylene group, an acenaphthylene group, a fluorenylene group, a spiro-bifluorenylene group, a spiro-benzofluorene-fluorenylene group, a benzofluorenylene group, a dibenzofluorenylene group, a phenalenylene group, a phenanthrenylene group, an anthracenylene group, a fluoranthenylene group, a triphenylenylene group, a pyrenylene group, a chrysenylene group, a perylenylene group, a pentaphenylene group, a pyrrolylene group, a thiophenylene group, a furanylene group, a silolylene group, an imidazolylene group, a pyrazolylene group, a thiazolylene group, an isothiazolylene group, an oxazolylene group, an isoxazolylene group, a pyridinylene group, a pyrazinylene group, a pyrimidinylene group, a pyridazinylene group, an indolylene group, an isoindolylene group, an indazolylene group, a purinylene group, a quinolinylene group, an isoquinolinylene group, a benzoquinolinylene group, a phthalazinylene group, a naphthyridinylene group, a quinoxalinylene group, a quinazolinylene group, a cinnolinylene group, a phenanthridinylene group, an acridinylene group, a phenanthrolinylene group, a phenazinylene group, a benzimidazolylene group, a benzofuranylene group, a benzothiofenylene group, a benzosilolylene group, an isobenzothiazolylene group, a benzoxazolylene group, an isobenzoxazolylene group, a triazolylene group, a tetrazolylene group, an oxadiazolylene group, a triazinylene group, a dibenzofuranylene group, a dibenzothiofenylene group, a dibenzosilolylene group, a carbazolylene group, a benzocarbazolylene group, a dibenzocarbazolylene group, a thiadiazolylene group, an imidazopyridinylene group, an imidazopyrimidinylene group, an oxazolopyridinylene group, a thiazolopyridinylene group, a benzonaphthyridinylene group, an azafluorenylene group, an azaspiro-bifluorenylene group, an azacarbazolylene group, an azadibenzofuranylene group, an azadibenzothiofenylene group, and an azadibenzosilolylene group, each substituted with at least one selected from deuterium, —F, —Cl, —Br, —I, a hydroxyl group, a cyano group, a nitro group, an amidino group, a hydrazino group, a hydrazono group, a C₁-C₂₀ alkyl group, a C₁-C₂₀ alkoxy group, a C₃-C₂₀ cycloalkoxy group, a C₃-C₁₀ cycloalkyl group, a C₁-C₁₀ heterocycloalkyl group, a C₃-C₁₀ cycloalkenyl group, a C₁-C₁₀ heterocycloalkenyl group, a C₆-C₆₀ aryl group, a C₁-C₆₀ heteroaryl group, a monovalent non-aromatic condensed polycyclic group, a monovalent non-aromatic condensed heteropolycyclic group, a biphenyl group, a terphenyl group, and —Si(Q₃₁)(Q₃₂)(Q₃₃).

[0075] Q₃₁ to Q₃₃ may each independently be selected from:

[0076] a C₁-C₁₀ alkyl group, a C₁-C₁₀ alkoxy group, a C₃-C₁₀ cycloalkoxy group, a phenyl group, a biphenyl group, a terphenyl group, a naphthyl group, a pyridinyl group, a pyrimidinyl group, a pyrazinyl group, a quinolinyl group, an isoquinolinyl group, a quinoxalinyl group, and a quinazolinyl group; and

[0077] a C₁-C₁₀ alkyl group, a C₁-C₁₀ alkoxy group, a C₃-C₁₀ cycloalkoxy group, a phenyl group, a biphenyl

group, a terphenyl group, a naphthyl group, a pyridinyl group, a pyrimidinyl group, a pyrazinyl group, a quinolinyl group, an isoquinolinyl group, a quinoxalinyl group, and a quinazoliny group, each substituted with at least one selected from a C₁-C₁₀ alkyl group, a C₁-C₁₀ alkoxy group, a C₃-C₁₀ cycloalkoxy group, a phenyl group, a biphenyl group, a terphenyl group, a naphthyl group, a pyridinyl group, a pyrimidinyl group, a pyrazinyl group, a quinolinyl group, an isoquinolinyl group, a quinoxalinyl group, and a quinazoliny group, and

[0078] * and *' each indicate a binding site to a neighboring atom.

[0079] In one embodiment, L₁ to L₅ and L₉ may each independently be selected from *—S—*', *—O—*', *—C(=O)—*', *—S(=O)—*', *—S(=O)₂—*', *—[C(Z₁)(Z₂)]_{n1}—*', and groups represented by Formulae 3-1 to 3-75, but embodiments of the present disclosure are not limited thereto:

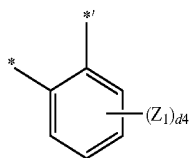

Formula 3-1

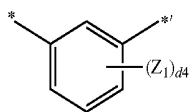

Formula 3-2

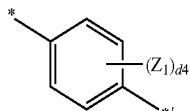

Formula 3-3

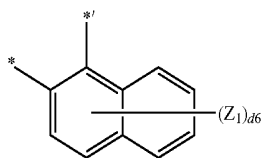

Formula 3-4

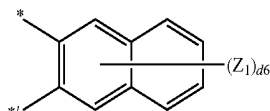

Formula 3-5

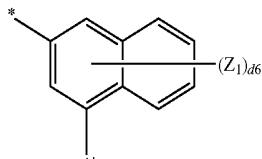

Formula 3-6

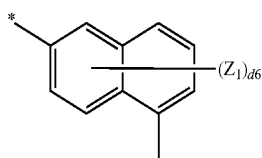

Formula 3-7

-continued

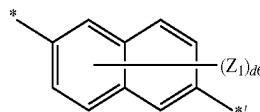

Formula 3-8

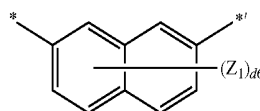

Formula 3-9

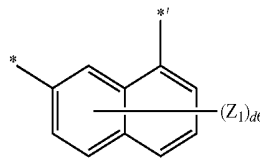

Formula 3-10

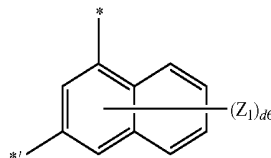

Formula 3-11

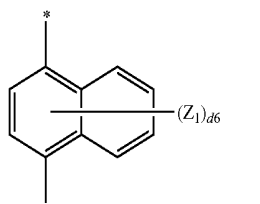

Formula 3-12

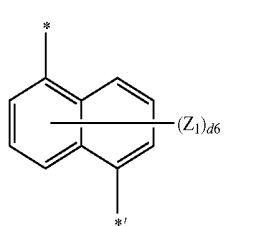

Formula 3-13

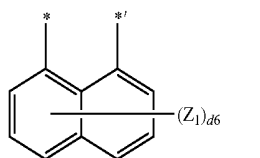

Formula 3-14

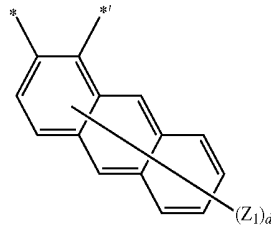

Formula 3-15

-continued

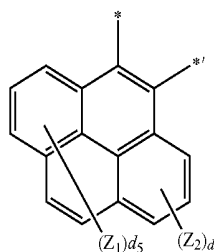
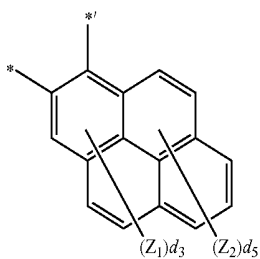
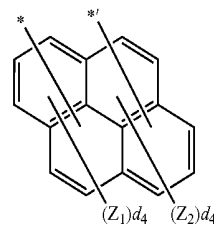
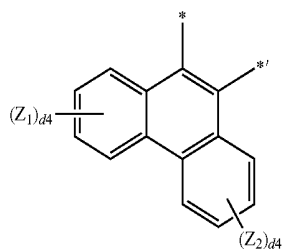
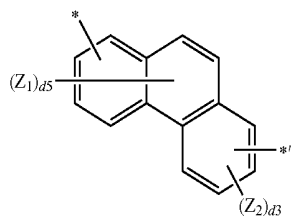
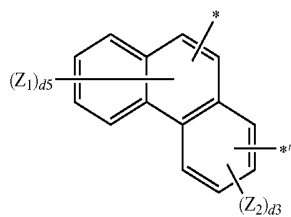

-continued

Formula 3-28

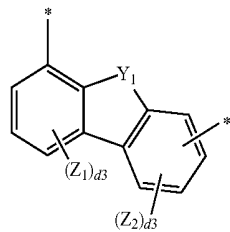

Formula 3-34

Formula 3-29

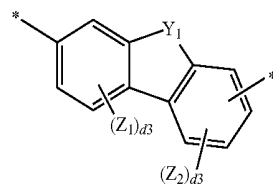

Formula 3-35

Formula 3-30

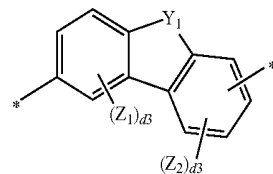

Formula 3-36

Formula 3-31

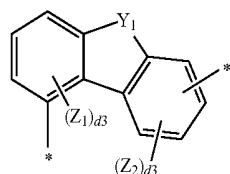

Formula 3-37

Formula 3-32

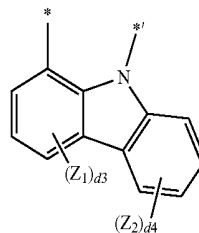

Formula 3-38

Formula 3-33

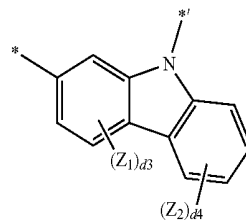

Formula 3-39

Formula 3-40

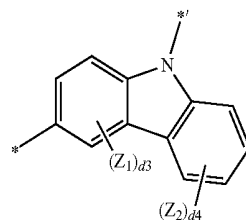

-continued

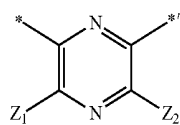
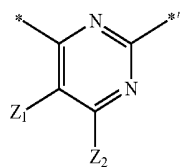
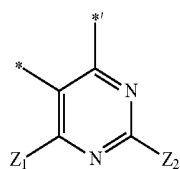
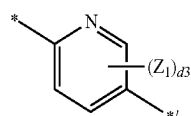
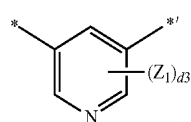
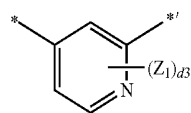
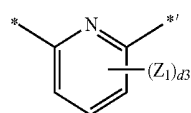
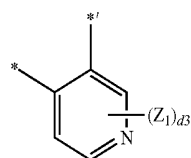
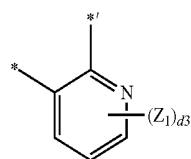
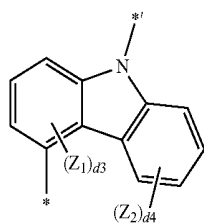

-continued

Formula 3-41

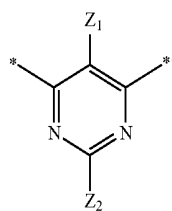

Formula 3-42

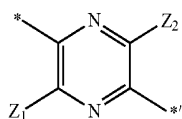

Formula 3-43

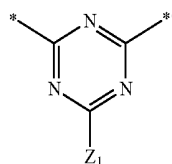

Formula 3-44

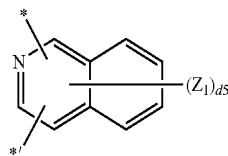

Formula 3-45

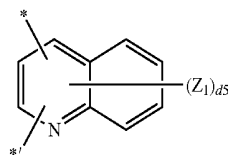

Formula 3-46

Formula 3-47

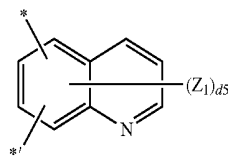

Formula 3-48

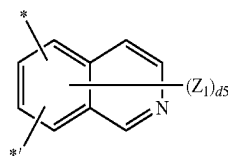

Formula 3-49

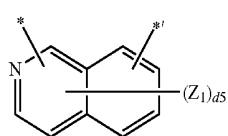

Formula 3-50

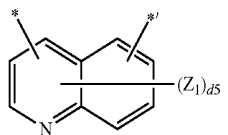

Formula 3-51

Formula-52

Formula 3-53

Formula 3-54

Formula 3-55

Formula 3-56

Formula 3-57

Formula 3-58

Formula 3-59

-continued

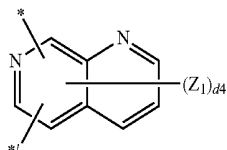

Formula 3-60

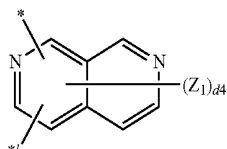

Formula 3-61

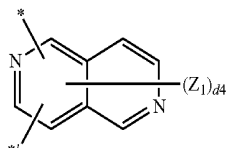

Formula 3-62

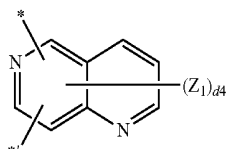

Formula 3-63

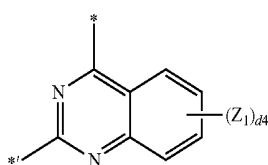

Formula 3-64

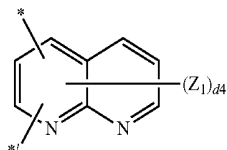

Formula 3-65

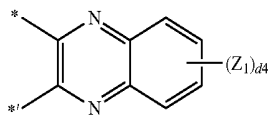

Formula 3-66

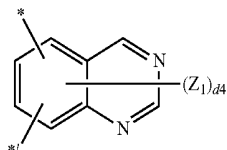

Formula 3-67

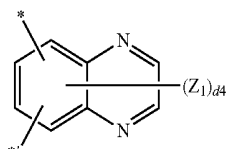

Formula 3-68

-continued

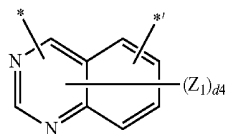

Formula 3-69

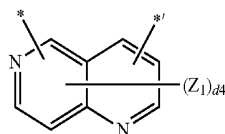

Formula 3-70

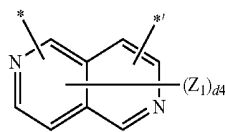

Formula 3-71

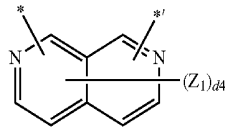

Formula 3-72

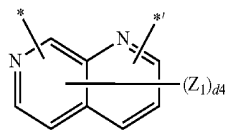

Formula 3-73

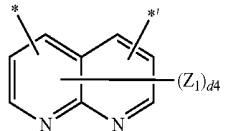

Formula 3-74

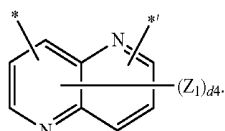

Formula 3-75

[0080] In Formulae 3-1 to 3-75,

[0081] Y_1 may be O, S, $C(Z_3)(Z_4)$, $N(Z_3)$, or $Si(Z_3)(Z_4)$,

[0082] Z_1 to Z_4 may each independently be selected from hydrogen, deuterium, $-F$, $-CF_3$, $-Cl$, $-Br$, $-I$, a hydroxyl group, a cyano group, a nitro group, an amidino group, a hydrazino group, a hydrazono group, a C_1 - C_{20} alkyl group, a C_1 - C_{20} alkoxy group, a C_3 - C_{20} cycloalkoxy group, a phenyl group, a biphenyl group, a terphenyl group, a naphthyl group, a fluorenyl group, a spiro-bifluorenyl group, a benzofluorenyl group, a dibenzofluorenyl group, a phenanthrenyl group, an anthracenyl group, a triphenylenyl group, a pyrenyl group, a chrysenyl group, a pyridinyl group, a pyrazinyl group, a pyrimidinyl group, a pyridazinyl group, a triazinyl group, and $-Si(Q_{31})(Q_{32})(Q_{33})$,

[0083] Q_{31} to Q_{33} may each independently be selected from a C_1 - C_{10} alkyl group, a C_1 - C_{10} alkoxy group, a C_3 - C_{20} cycloalkoxy group, a phenyl group, a biphenyl group, a terphenyl group, and a naphthyl group,

[0084] d_3 may be an integer from 1 to 3,

[0085] d_4 may be an integer from 1 to 4,

[0086] d_5 may be an integer from 1 to 5,

[0087] d_6 may be an integer from 1 to 6,

[0088] d8 may be an integer from 1 to 8,
 [0089] n1 may be an integer from 1 to 20, and
 [0090] * and *' each indicate a binding site to a neighboring atom.

[0091] a1 to a5 and a9 in Formulae 1, 2-1, 2-2, and 2-4 may each independently be an integer from 0 to 10. a1 indicates the number of L₁(s), wherein, when a1 is zero, *-L₁-*' may be a single bond, and when a1 is two or more, two or more L₁(s) may be identical to or different from each other.

[0092] For example, a1 to a5 and a9 may each independently be an integer from 0 to 6.

[0093] In one embodiment, a1 to a5 and a9 may each independently be an integer from 0 to 3.

[0094] In one or more embodiments, a1 to a5 and a9 may each independently be 0, 1, or 2, but embodiments of the present disclosure are not limited thereto.

[0095] In one embodiment, Ar₁ in Formula 1 may be selected from groups represented by Formulae 4-1 to 4-59, and L₁ to L₅ and L₉ in Formulae 1, 2-1, 2-2, and 2-4 may each independently be selected from *-O-*, *-C(=O)-*, *-CH₂-*, *-(CH₂)₂-*, *-(CH₂)₃-*, *-(CH₂)₄-*, *-(CH₂)₅-*, and groups represented by Formulae 4-1 to 4-58 and 4-60, but embodiments of the present disclosure are not limited thereto:

-continued

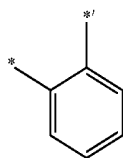

Formula 4-1

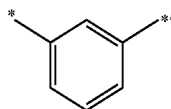

Formula 4-2

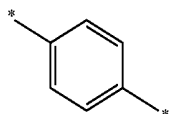

Formula 4-3

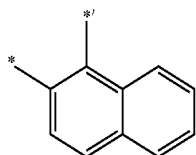

Formula 4-4

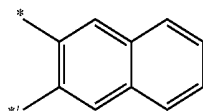

Formula 4-5

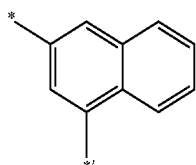

Formula 4-6

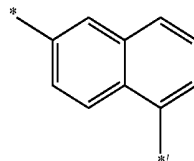

Formula 4-7

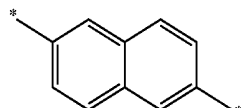

Formula 4-8

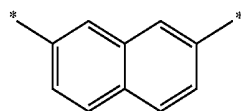

Formula 4-9

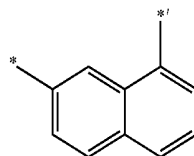

Formula 4-10

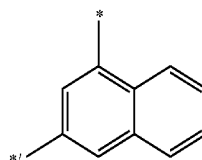

Formula 4-11

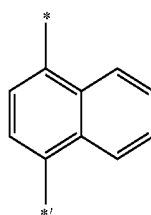

Formula 4-12

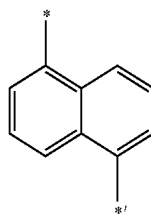

Formula 4-13

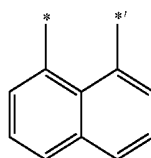

Formula 4-14

-continued

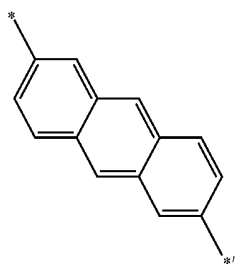
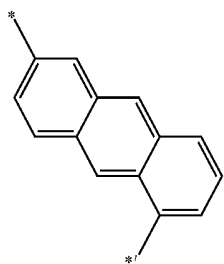
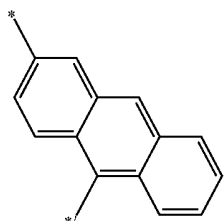
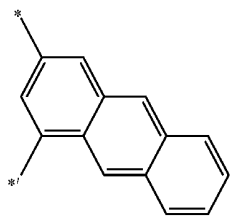
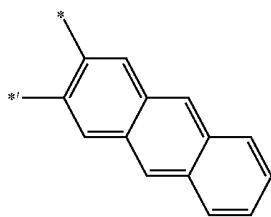
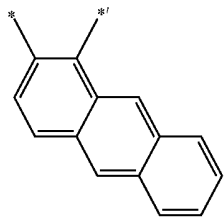

Formula 4-15

Formula 4-16

Formula 4-17

Formula 4-18

Formula 4-19

Formula 4-20

-continued

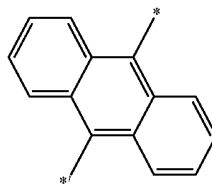
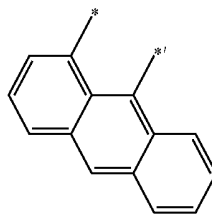
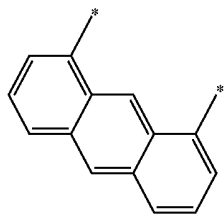
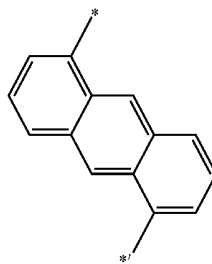
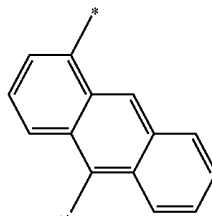
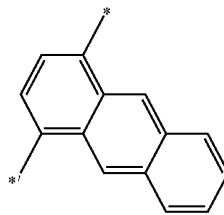
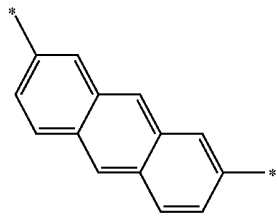

Formula 4-21

Formula 4-22

Formula 4-23

Formula 4-24

Formula 4-25

Formula 4-26

Formula 4-27

-continued

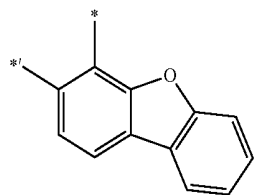
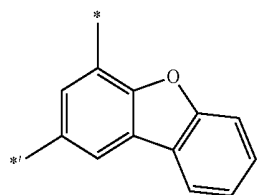
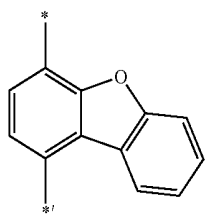
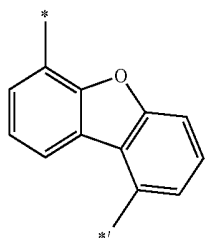
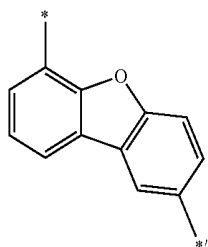
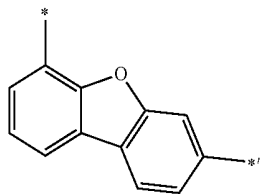
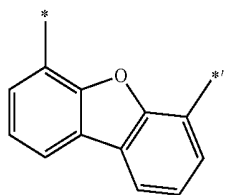

Formula 4-28

Formula 4-29

Formula 4-30

Formula 4-31

Formula 4-32

Formula 4-33

Formula 4-34

-continued

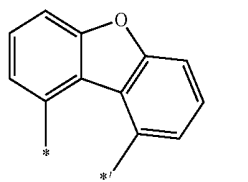
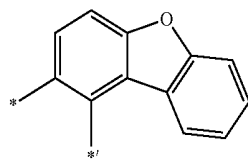
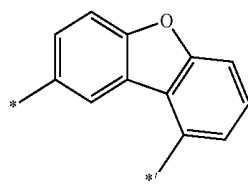
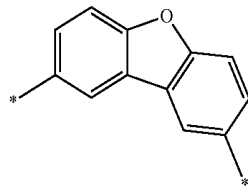
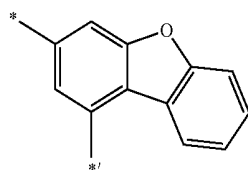
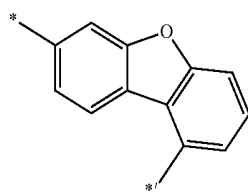
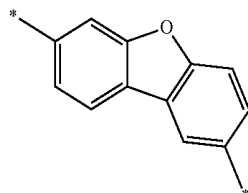
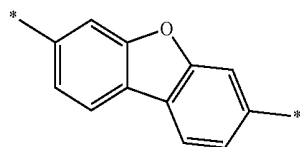

Formula 4-35

Formula 4-36

Formula 4-37

Formula 4-38

Formula 4-39

Formula 4-40

Formula 4-41

Formula 4-42

-continued

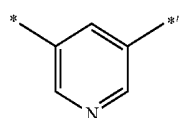
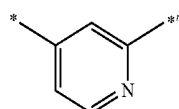
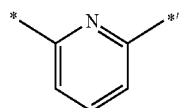
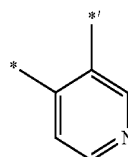
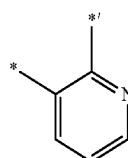
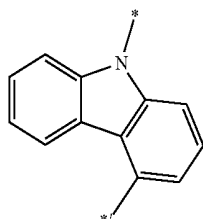
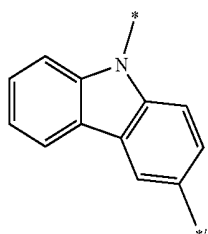
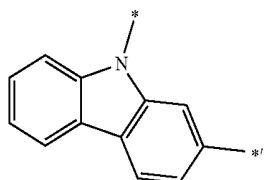
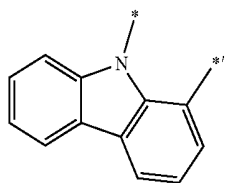

Formula 4-43

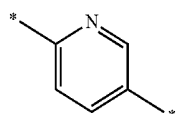

Formula 4-44

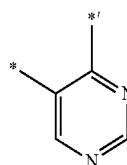

Formula 4-45

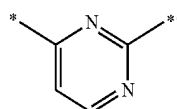

Formula 4-46

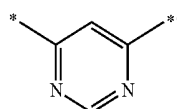

Formula 4-47

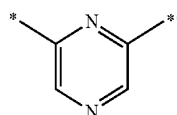

Formula 4-48

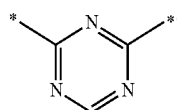

Formula 4-49

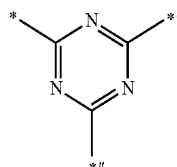

Formula 4-50

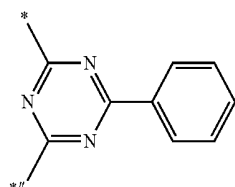

Formula 4-51

-continued

Formula 4-52

Formula 4-53

Formula 4-54

Formula 4-55

Formula 4-56

Formula 4-57

Formula 4-58

Formula 4-59

Formula 4-60

[0096] *, *', and *'' in Formulae 4-1 to 4-60 each indicate a binding site to a neighboring atom.

[0097] R₁ in Formula 1 may be a group represented by Formula 2-1 or a group represented by Formula 2-2.

[0098] For example, the group represented by Formula 2-1 may be a group represented by Formula 2-1A, but embodiments of the present disclosure are not limited thereto:

Formula 2-1A

[0099]

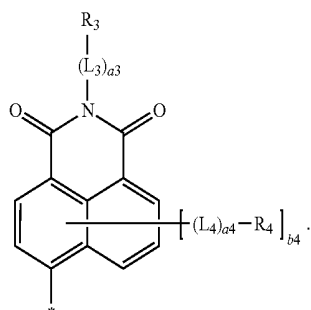

[0100] In Formula 2-1A, L_3 , L_4 , a_3 , a_4 , R_3 , R_4 , and b_4 are the same as described above, and * indicates a binding site to a neighboring atom.

[0101] In one embodiment, in Formulae 1, 2-1, and 2-2, R_2 to R_5 may each independently be selected from:

[0102] a group represented by Formula 2-3, a group represented by Formula 2-4, hydrogen, deuterium, —F, —Cl, —Br, —I, a hydroxyl group, a cyano group, a nitro group, an amidino group, a hydrazino group, a hydrazono group, $\text{Si}(\text{Q}_1)(\text{Q}_2)(\text{Q}_3)$, a C_1 - C_{20} alkyl group, a C_3 - C_{10} cycloalkyl group, a C_1 - C_{10} heterocycloalkyl group, a C_1 - C_{20} alkoxy group, and a C_3 - C_{20} cycloalkoxy group;

[0103] a C_1 - C_{20} alkyl group, a C_3 - C_{10} cycloalkyl group, a C_1 - C_{10} heterocycloalkyl group, a C_1 - C_{20} alkoxy group, and a C_3 - C_{20} cycloalkoxy group, each substituted with at least one selected from deuterium, —F, —Cl, —Br, —I, a hydroxyl group, a cyano group, a nitro group, an amidino group, a hydrazino group, and a hydrazono group;

[0104] a cyclopentyl group, a cyclohexyl group, a cycloheptyl group, a cyclopentenyl group, a cyclohexenyl group, a phenyl group, a biphenyl group, a terphenyl group, a pentalenyl group, an indenyl group, a naphthyl group, an azulenyl group, an indacenyl group, an acenaphthyl group, a fluorenyl group, a spiro-bifluorenyl group, a spiro-benzofluorene-fluorenyl group, a benzofluorenyl group, a dibenzofluorenyl group, a phenalenyl group, a phenanthrenyl group, an anthracenyl group, a fluoranthenyl group, a triphenylenyl group, a pyrenyl group, a chrysenyl group, a perylenyl group, a pentaphenyl group, a pyrrolyl group, a thiophenyl group, a furanyl group, a silolyl group, an imidazolyl group, a pyrazolyl group, a thiazolyl group, an isothiazolyl group, an oxazolyl group, an isoxazolyl group, a pyridinyl group, a pyrazinyl group, a pyrimidinyl group, a pyridazinyl group, an indolyl group, an isoindolyl group, an indazolyl group, a purinyl group, a quinolinyl group, an isoquinolinyl group, a benzoquinolinyl group, a phthalazinyl group, a naphthyridinyl group, a quinoxalinyl group, a quinazolinyl group, a cinnolinyl group, a phenanthridinyl group, an acridinyl group, a phenanthrolinyl group, a phenazinyl group, a benzimidazolyl group, a benzofuran group, a benzothiophenyl group, a benzosilolyl group, an isobenzothiazolyl group, a benzoxazolyl group, an isobenzoxazolyl group, a triazolyl group, a tetrazolyl group, an oxadiazolyl group, a triazinyl group, a dibenzofuran group, a dibenzothiophenyl group, a dibenzosilolyl group, a carbazolyl group, a benzocarbazolyl group, a dibenzocarbazolyl group, a thiadiazolyl group, an imidazopyridinyl group, an imidazopyrimidinyl group, an oxazolopyridinyl group, a thiazolopyridinyl group, a benzonaphthyridinyl group, an azafluorenyl group, an azaspiro-bifluorenyl group, an azacarbazolyl group, an azadibenzofuran group, an azadibenzothiophenyl group, and an azadibenzosilolyl group, each substituted with at least one selected from deuterium, —F, —Cl, —Br, —I, a hydroxyl group, a cyano group, a nitro group, an amidino group, a hydrazino group, a hydrazono group, a C_1 - C_{20} alkyl group, a C_1 - C_{20} alkoxy group, a C_3 - C_{20} cycloalkoxy group, a C_3 - C_{10} cycloalkyl group, a C_1 - C_{10} heterocycloalkyl group, a C_3 - C_{10} cycloalkenyl group, a C_1 - C_{10} heterocycloalkenyl group, a C_6 - C_{60} aryl group, a C_1 - C_{60} heteroaryl group, a monovalent non-aromatic condensed polycyclic group, a monovalent non-aromatic condensed heteropolycyclic group, a biphenyl group, a terphenyl group and $-\text{Si}(\text{Q}_{31})(\text{Q}_{32})(\text{Q}_{33})$, and

group, an imidazopyrimidinyl group, an oxazolopyridinyl group, a thiazolopyridinyl group, a benzonaphthyridinyl group, an azafluorenyl group, an azaspiro-bifluorenyl group, an azacarbazolyl group, an azadibenzofuran group, an azadibenzothiophenyl group, and an azadibenzosilolyl group; and

[0105] a cyclopentyl group, a cyclohexyl group, a cycloheptyl group, a cyclopentenyl group, a cyclohexenyl group, a phenyl group, a biphenyl group, a terphenyl group, a pentalenyl group, an indenyl group, a naphthyl group, an azulenyl group, an indacenyl group, an acenaphthyl group, a fluorenyl group, a spiro-bifluorenyl group, a spiro-benzofluorene-fluorenyl group, a benzofluorenyl group, a dibenzofluorenyl group, a phenalenyl group, a phenanthrenyl group, an anthracenyl group, a fluoranthenyl group, a triphenylenyl group, a pyrenyl group, a chrysenyl group, a perylenyl group, a pentaphenyl group, a pyrrolyl group, a thiophenyl group, a furanyl group, a silolyl group, an imidazolyl group, a pyrazolyl group, a thiazolyl group, an isothiazolyl group, an oxazolyl group, an isoxazolyl group, a pyridinyl group, a pyrazinyl group, a pyrimidinyl group, a pyridazinyl group, an indolyl group, an isoindolyl group, an indazolyl group, a purinyl group, a quinolinyl group, an isoquinolinyl group, a benzoquinolinyl group, a phthalazinyl group, a naphthyridinyl group, a quinoxalinyl group, a quinazolinyl group, a cinnolinyl group, a phenanthridinyl group, an acridinyl group, a phenanthrolinyl group, a phenazinyl group, a benzimidazolyl group, a benzofuran group, a benzothiophenyl group, a benzosilolyl group, an isobenzothiazolyl group, a benzoxazolyl group, an isobenzoxazolyl group, a triazolyl group, a tetrazolyl group, an oxadiazolyl group, a triazinyl group, a dibenzofuran group, a dibenzothiophenyl group, a dibenzosilolyl group, a carbazolyl group, a benzocarbazolyl group, a dibenzocarbazolyl group, a thiadiazolyl group, an imidazopyridinyl group, an imidazopyrimidinyl group, an oxazolopyridinyl group, a thiazolopyridinyl group, a benzonaphthyridinyl group, an azafluorenyl group, an azaspiro-bifluorenyl group, an azacarbazolyl group, an azadibenzofuran group, an azadibenzothiophenyl group, and an azadibenzosilolyl group, each substituted with at least one selected from deuterium, —F, —Cl, —Br, —I, a hydroxyl group, a cyano group, a nitro group, an amidino group, a hydrazino group, a hydrazono group, a C_1 - C_{20} alkyl group, a C_1 - C_{20} alkoxy group, a C_3 - C_{20} cycloalkoxy group, a C_3 - C_{10} cycloalkyl group, a C_1 - C_{10} heterocycloalkyl group, a C_3 - C_{10} cycloalkenyl group, a C_1 - C_{10} heterocycloalkenyl group, a C_6 - C_{60} aryl group, a C_1 - C_{60} heteroaryl group, a monovalent non-aromatic condensed polycyclic group, a monovalent non-aromatic condensed heteropolycyclic group, a biphenyl group, a terphenyl group and $-\text{Si}(\text{Q}_{31})(\text{Q}_{32})(\text{Q}_{33})$, and

[0106] Q_1 to Q_3 and Q_{31} to Q_{33} may each independently be selected from:

[0107] a C_1 - C_{10} alkyl group, a C_1 - C_{10} alkoxy group, a phenyl group, a biphenyl group, a terphenyl group, a naphthyl group, a pyridinyl group, a pyrimidinyl group, a pyrazinyl group, a quinolinyl group, an isoquinolinyl group, a quinoxalinyl group, and a quinazolinyl group; and

[0108] a phenyl group, a biphenyl group, a terphenyl group, a naphthyl group, a pyridinyl group, a pyrimidinyl group, a pyrazinyl group, a quinolinyl group, an isoquinolinyl group, a quinoxalinyl group, and a quinazolinyl group, each substituted with at least one selected from a C_1 - C_{10} alkyl group, a C_1 - C_{10} alkoxy group, and a phenyl group.

[0109] In one embodiment, R_2 to R_5 may each independently be selected from:

[0110] a group represented by Formula 2-3, a group represented by Formula 2-4, hydrogen, deuterium, —F, —Cl, —Br, —I, a hydroxyl group, a cyano group, a nitro group, an amidino group, a hydrazino group, a hydrazono group, a C_1 - C_{20} alkyl group, a C_3 - C_{10} cycloalkyl group, a C_1 - C_{20} alkoxy group, a C_3 - C_{20} cycloalkoxy group, a phenyl group, a biphenyl group, a terphenyl group, a naphthyl group, a fluorenyl group, a spiro-bifluorenyl group, a benzofluorenyl group, a dibenzofluorenyl group, a phenanthrenyl group, an anthracenyl group, a triphenylenyl group, a pyrenyl group, a chrysenyl group, a carbazolyl group, a benzocarbazolyl group, a dibenzocarbazolyl group, a furanyl group, a benzofuranyl group, a dibenzofuranyl group, a thiophenyl group, a benzothiophenyl group, a dibenzothiophenyl group, a pyridinyl group, a pyrazinyl group, a pyrimidinyl group, a pyridazinyl group, a triazinyl group, and —Si(Q_1)(Q_2)(Q_3); and

[0111] a C_1 - C_{20} alkyl group, a C_3 - C_{10} cycloalkyl group, a C_1 - C_{20} alkoxy group, a C_3 - C_{20} cycloalkoxy group, a phenyl group, a biphenyl group, a terphenyl group, a naphthyl group, a fluorenyl group, a spiro-bifluorenyl group, a benzofluorenyl group, a dibenzofluorenyl group, a phenanthrenyl group, an anthracenyl group, a triphenylenyl group, a pyrenyl group, a chrysenyl group, a carbazolyl group, a benzocarbazolyl group, a dibenzocarbazolyl group, a furanyl group, a benzofuranyl group, a dibenzofuranyl group, a thiophenyl group, a benzothiophenyl group, a dibenzothiophenyl group, a pyridinyl group, a pyrazinyl group, a pyrimidinyl group, a pyridazinyl group, and a triazinyl group, each substituted with at least one selected from deuterium, —F, —Cl, —Br, —I, a hydroxyl group, a cyano group, a nitro group, an amidino group, a hydrazino group, a hydrazono group, a C_1 - C_{20} alkyl group, a C_3 - C_{10} cycloalkyl group, a C_1 - C_{20} alkoxy group, a C_3 - C_{20} cycloalkoxy group, a phenyl group, a biphenyl group, a terphenyl group, a naphthyl group, a fluorenyl group, a spiro-bifluorenyl group, a benzofluorenyl group, a phenanthrenyl group, an anthracenyl group, a triphenylenyl group, a pyrenyl group, a chrysenyl group, a carbazolyl group, a benzocarbazolyl group, a dibenzocarbazolyl group, a furanyl group, a benzofuranyl group, a dibenzofuranyl group, a thiophenyl group, a benzothiophenyl group, a dibenzothiophenyl group, a pyridinyl group, a pyrazinyl group, a pyrimidinyl group, a pyridazinyl group, a triazinyl group, and —Si(Q_3)(Q_2)(Q_3), and

[0112] Q_1 to Q_3 and Q_{31} to Q_{33} may each independently be selected from a C_1 - C_{10} alkyl group, a C_1 - C_{10} alkoxy group, a phenyl group, a biphenyl group, a terphenyl group, and a naphthyl group.

[0113] In one or more embodiments, R_2 to R_5 may each independently be selected from a group represented by Formula 2-3, a group represented by Formula 2-4, hydrogen, deuterium, —F, —Cl, —Br, —I, a hydroxyl group, a cyano group, a nitro group, an amidino group, a hydrazino group, a hydrazono group, a C_1 - C_{20} alkyl group, a C_3 - C_{10} cycloalkyl group, a C_1 - C_{20} alkoxy group, a C_3 - C_{20} cycloalkoxy group, a phenyl group, a biphenyl group, a terphenyl group, a naphthyl group, an anthracenyl group, a carbazolyl group, a dibenzofuranyl group, a dibenzothiophenyl group, a pyridinyl group, a pyrazinyl group, a pyrimidinyl group, a pyridazinyl group, a triazinyl group, and —Si(Q_1)(Q_2)(Q_3); and

[0114] a C_1 - C_{20} alkyl group, a C_3 - C_{10} cycloalkyl group, a C_1 - C_{20} alkoxy group, a phenyl group, a biphenyl group, a terphenyl group, a naphthyl group, an anthracenyl group, a carbazolyl group, a dibenzofuranyl group, a dibenzothiophenyl group, a pyridinyl group, a pyrazinyl group, a pyrimidinyl group, a pyridazinyl group, and a triazinyl group, each substituted with at least one selected from deuterium, —F, —Cl, —Br, —I, a hydroxyl group, a cyano group, a nitro group, an amidino group, a hydrazino group, a hydrazono group, a C_1 - C_{20} alkyl group, a C_3 - C_{10} cycloalkyl group, a C_1 - C_{20} alkoxy group, a C_3 - C_{20} cycloalkoxy group, a phenyl group, a biphenyl group, a terphenyl group, a naphthyl group, an anthracenyl group, a carbazolyl group, a dibenzofuranyl group, a dibenzothiophenyl group, a pyridinyl group, a pyrazinyl group, a pyrimidinyl group, a pyridazinyl group, a triazinyl group, and —Si(Q_{31})(Q_{32})(Q_{33}), and

[0115] Q_1 to Q_3 and Q_{31} to Q_{33} may each independently be selected from a C_1 - C_{10} alkyl group, a C_1 - C_{10} alkoxy group, a phenyl group, a biphenyl group, a terphenyl group, and a naphthyl group, but embodiments of the present disclosure are not limited thereto.

[0116] In Formulae 1, 2-3, and 2-4, R_6 to R_9 , R_{11} , and R_{12} may each independently be selected from hydrogen, deuterium, —F, —Cl, —Br, —I, a hydroxyl group, a cyano group, a nitro group, an amidino group, a hydrazino group, a hydrazono group, a substituted or unsubstituted C_1 - C_{60} alkyl group, a substituted or unsubstituted C_2 - C_{60} alkenyl group, a substituted or unsubstituted C_2 - C_{60} alkynyl group, a substituted or unsubstituted C_1 - C_{60} alkoxy group, a substituted or unsubstituted C_3 - C_{60} cycloalkoxy group, a substituted or unsubstituted C_3 - C_{10} cycloalkyl group, a substituted or unsubstituted C_1 - C_{10} heterocycloalkyl group, a substituted or unsubstituted C_3 - C_{10} cycloalkenyl group, a substituted or unsubstituted C_1 - C_{10} heterocycloalkenyl group, a substituted or unsubstituted C_6 - C_{60} aryl group, a substituted or unsubstituted C_6 - C_{60} aryloxy group, a substituted or unsubstituted C_6 - C_{60} arylthio group, a substituted or unsubstituted C_1 - C_{60} heteroaryl group, a substituted or unsubstituted monovalent non-aromatic condensed polycyclic group, a substituted or unsubstituted monovalent non-aromatic condensed heteropolycyclic group, Si(Q_4)(Q_5)(Q_6), —N(Q_4)(Q_5), —B(Q_4)(Q_5), —C(=O)(Q_4), —S(=O)₂(Q_4), and —P(=O)(Q_4)(Q_5), and

[0117] Q_4 to Q_6 are the same as described above.

[0118] For example, R_6 to R_9 , R_{11} , and R_{12} may each independently be selected from:

[0119] hydrogen, deuterium, —F, —Cl, —Br, —I, a hydroxyl group, a cyano group, a nitro group, an amidino group, a hydrazino group, a hydrazono group, Si(Q_4)(Q_5)(Q_6), a C_1 - C_{20} alkyl group, a C_3 - C_{10} cycloalkyl group, a C_1 - C_{10} heterocycloalkyl group, a C_1 - C_{20} alkoxy group, and a C_3 - C_{20} cycloalkoxy group;

[0120] a C_1 - C_{20} alkyl group, a C_3 - C_{10} cycloalkyl group, a C_1 - C_{10} heterocycloalkyl group, a C_1 - C_{20} alkoxy group, and a C_3 - C_{20} cycloalkoxy group, each substituted with at least one selected from deuterium, —F, —Cl, —Br, —I, a hydroxyl group, a cyano group, a nitro group, an amidino group, a hydrazino group, and a hydrazono group;

[0121] a cyclopentyl group, a cyclohexyl group, a cycloheptyl group, a cyclopentenyl group, a cyclohexenyl group, a phenyl group, a biphenyl group, a terphenyl group, a pentalenyl group, an indenyl group, a naphthyl group, an azulenyl group, an indacenyl group, an acenaphthyl group,

a fluorenyl group, a spiro-bifluorenyl group, a spiro-benzofluorene-fluorenyl group, a benzofluorenyl group, a dibenzofluorenyl group, a phenalenyl group, a phenanthrenyl group, an anthracenyl group, a fluoranthenyl group, a triphenylenyl group, a pyrenyl group, a chrysenyl group, a perylenyl group, a pentaphenyl group, a pyrrolyl group, a thiophenyl group, a furanyl group, a silolyl group, an imidazolyl group, a pyrazolyl group, a thiazolyl group, an isothiazolyl group, an oxazolyl group, an isoxazolyl group, a pyridinyl group, a pyrazinyl group, a pyrimidinyl group, a pyridazinyl group, an indolyl group, an isoindolyl group, an indazolyl group, a purinyl group, a quinolyl group, an isoquinolyl group, a benzoquinolyl group, a phthalazinyl group, a naphthyridinyl group, a quinoxalinyl group, a quinazolinyl group, a cinnolinyl group, a phenanthridinyl group, an acridinyl group, a phenanthrolinyl group, a phenazinyl group, a benzimidazolyl group, a benzofuranlyl group, a benzothiophenyl group, a benzosilolyl group, an isobenzothiazolyl group, a benzoxazolyl group, an isobenzoxazolyl group, a triazolyl group, a tetrazolyl group, an oxadiazolyl group, a triazinyl group, a dibenzofuranlyl group, a dibenzothiophenyl group, a dibenzosilolyl group, a carbazolyl group, a benzocarbazolyl group, a dibenzocarbazolyl group, a thiadiazolyl group, an imidazopyridinyl group, an imidazopyrimidinyl group, an oxazolopyridinyl group, a thiazolopyridinyl group, a benzonaphthyridinyl group, an azafluorenyl group, an azaspiro-bifluorenyl group, an azacarbazolyl group, an azadibenzofuranlyl group, an azadibenzothiophenyl group, and an azadibenzosilolyl group; and

[0122] a cyclopentyl group, a cyclohexyl group, a cycloheptyl group, a cyclopentenyl group, a cyclohexenyl group, a phenyl group, a biphenyl group, a terphenyl group, a pentalenyl group, an indenyl group, a naphthyl group, an azulenyl group, an indacenyl group, an acenaphthyl group, a fluorenyl group, a spiro-bifluorenyl group, a spiro-benzofluorene-fluorenyl group, a benzofluorenyl group, a dibenzofluorenyl group, a phenalenyl group, a phenanthrenyl group, an anthracenyl group, a fluoranthenyl group, a triphenylenyl group, a pyrenyl group, a chrysenyl group, a perylenyl group, a pentaphenyl group, a pyrrolyl group, a thiophenyl group, a furanyl group, a silolyl group, an imidazolyl group, a pyrazolyl group, a thiazolyl group, an isothiazolyl group, an oxazolyl group, an isoxazolyl group, a pyridinyl group, a pyrazinyl group, a pyrimidinyl group, a pyridazinyl group, an indolyl group, an isoindolyl group, an indazolyl group, a purinyl group, a quinolyl group, an isoquinolyl group, a benzoquinolyl group, a phthalazinyl group, a naphthyridinyl group, a quinoxalinyl group, a quinazolinyl group, a cinnolinyl group, a phenanthridinyl group, an acridinyl group, a phenanthrolinyl group, a phenazinyl group, a benzimidazolyl group, a benzofuranlyl group, a benzothiophenyl group, a benzosilolyl group, an isobenzothiazolyl group, a benzoxazolyl group, an isobenzoxazolyl group, a triazolyl group, a tetrazolyl group, an oxadiazolyl group, a triazinyl group, a dibenzofuranlyl group, a dibenzothiophenyl group, a dibenzosilolyl group, a carbazolyl group, a benzocarbazolyl group, a dibenzocarbazolyl group, a thiadiazolyl group, an imidazopyridinyl group, an imidazopyrimidinyl group, an oxazolopyridinyl group, a thiazolopyridinyl group, a benzonaphthyridinyl group, an azafluorenyl group, an azaspiro-bifluorenyl group, an azacarbazolyl group, an azadibenzofuranlyl group, an azadibenzothiophenyl group, and an azadibenzosilolyl

group, each substituted with at least one selected from deuterium, —F, —Cl, —Br, —I, a hydroxyl group, a cyano group, a nitro group, an amidino group, a hydrazino group, a hydrazono group, a C₁-C₂₀ alkyl group, a C₁-C₂₀ alkoxy group, a C₃-C₂₀ cycloalkoxy group, a C₃-C₁₀ cycloalkyl group, a C₁-C₁₀ heterocycloalkyl group, a C₃-C₁₀ cycloalkenyl group, a C₁-C₁₀ heterocycloalkenyl group, a C₆-C₆₀ aryl group, a C₁-C₆₀ heteroaryl group, a monovalent non-aromatic condensed polycyclic group, a monovalent non-aromatic condensed heteropolycyclic group, a biphenyl group, a terphenyl group, and —Si(Q₃₁)(Q₃₂)(Q₃₃), and

[0123] Q₄ to Q₆ and Q₃₁ to Q₃₃ may each independently be selected from:

[0124] a C₁-C₁₀ alkyl group, a C₁-C₁₀ alkoxy group, a phenyl group, a biphenyl group, a terphenyl group, a naphthyl group, a pyridinyl group, a pyrimidinyl group, a pyrazinyl group, a quinolyl group, an isoquinolyl group, a quinoxalinyl group, and a quinazolinyl group; and

[0125] a phenyl group, a biphenyl group, a terphenyl group, a naphthyl group, a pyridinyl group, a pyrimidinyl group, a pyrazinyl group, a quinolyl group, an isoquinolyl group, a quinoxalinyl group, and a quinazolinyl group, each substituted with at least one selected from a C₁-C₁₀ alkyl group, a C₁-C₁₀ alkoxy group, and a phenyl group.

[0126] In one embodiment, R₆ to R₉, R₁₁, and R₁₂ may each independently be selected from:

[0127] hydrogen, deuterium, —F, —Cl, —Br, —I, a hydroxyl group, a cyano group, a nitro group, an amidino group, a hydrazino group, a hydrazono group, a C₁-C₂₀ alkyl group, a C₃-C₁₀ cycloalkyl group, a C₁-C₂₀ alkoxy group, a C₃-C₂₀ cycloalkoxy group, a phenyl group, a biphenyl group, a terphenyl group, a naphthyl group, a fluorenyl group, a spiro-bifluorenyl group, a benzofluorenyl group, a dibenzofluorenyl group, a phenanthrenyl group, an anthracenyl group, a triphenylenyl group, a pyrenyl group, a chrysenyl group, a carbazolyl group, a benzocarbazolyl group, a dibenzocarbazolyl group, a furanyl group, a benzofuranlyl group, a dibenzofuranlyl group, a thiophenyl group, a benzothiophenyl group, a dibenzothiophenyl group, a pyridinyl group, a pyrazinyl group, a pyrimidinyl group, a pyridazinyl group, a triazinyl group, and —Si(Q₄)(Q₅)(Q₆); and

[0128] a C₁-C₂₀ alkyl group, a C₃-C₁₀ cycloalkyl group, a C₁-C₂₀ alkoxy group, a C₃-C₂₀ cycloalkoxy group, a phenyl group, a biphenyl group, a terphenyl group, a naphthyl group, a fluorenyl group, a spiro-bifluorenyl group, a benzofluorenyl group, a dibenzofluorenyl group, a phenanthrenyl group, an anthracenyl group, a triphenylenyl group, a pyrenyl group, a chrysenyl group, a carbazolyl group, a benzocarbazolyl group, a dibenzocarbazolyl group, a furanyl group, a benzofuranlyl group, a dibenzofuranlyl group, a thiophenyl group, a benzothiophenyl group, a dibenzothiophenyl group, a pyridinyl group, a pyrazinyl group, a pyrimidinyl group, a pyridazinyl group, and a triazinyl group, each substituted with at least one selected from deuterium, —F, —Cl, —Br, —I, a hydroxyl group, a cyano group, a nitro group, an amidino group, a hydrazino group, a hydrazono group, a C₁-C₂₀ alkyl group, a C₃-C₁₀ cycloalkyl group, a C₁-C₂₀ alkoxy group, a C₃-C₂₀ cycloalkoxy group, a phenyl group, a biphenyl group, a terphenyl group, a naphthyl group, a fluorenyl group, a spiro-bifluorenyl group, a benzofluorenyl group, a dibenzofluorenyl group, a phenanthrenyl group, an anthracenyl group, a triphenylenyl group, a pyrenyl group, a chrysenyl

group, a carbazolyl group, a benzocarbazolyl group, a dibenzocarbazolyl group, a furanyl group, a benzofuranyl group, a dibenzofuranyl group, a thiophenyl group, a benzothio-phenyl group, a dibenzothiophenyl group, a pyridinyl group, a pyrazinyl group, a pyrimidinyl group, a pyridazinyl group, a triazinyl group and $-\text{Si}(\text{Q}_{31})(\text{Q}_{32})(\text{Q}_{33})$, and

[0129] Q_4 to Q_6 and Q_{31} to Q_{33} may each independently be selected from a C_1 - C_{10} alkyl group, a C_1 - C_{10} alkoxy group, a phenyl group, a biphenyl group, a terphenyl group, and a naphthyl group.

[0130] In one or more embodiments, R_6 to R_9 , R_{11} , and R_{12} may each independently be selected from hydrogen, deuterium, $-\text{F}$, $-\text{Cl}$, $-\text{Br}$, $-\text{I}$, a hydroxyl group, a cyano group, a nitro group, an amidino group, a hydrazino group, a hydrazono group, a C_1 - C_{20} alkyl group, a C_3 - C_{10} cycloalkyl group, a C_1 - C_{20} alkoxy group, a C_3 - C_{20} cycloalkoxy group, a phenyl group, a biphenyl group, a terphenyl group, a naphthyl group, an anthracenyl group, a carbazolyl group, a dibenzofuranyl group, a dibenzothiophenyl group, a pyridinyl group, a pyrazinyl group, a pyrimidinyl group, a pyridazinyl group, a triazinyl group and $-\text{Si}(\text{Q}_4)(\text{Q}_5)(\text{Q}_6)$; and

[0131] a C_1 - C_{20} alkyl group, a C_3 - C_{10} cycloalkyl group, a C_1 - C_{20} alkoxy group, a phenyl group, a biphenyl group, a terphenyl group, a naphthyl group, an anthracenyl group, a carbazolyl group, a dibenzofuranyl group, a dibenzothiophenyl group, a pyridinyl group, a pyrazinyl group, a pyrimidinyl group, a pyridazinyl group, and a triazinyl group, each substituted with at least one selected from deuterium, $-\text{F}$, $-\text{Cl}$, $-\text{Br}$, $-\text{I}$, a hydroxyl group, a cyano group, a nitro group, an amidino group, a hydrazino group, a hydrazono group, a C_1 - C_{20} alkyl group, a C_3 - C_{10} cycloalkyl group, a C_1 - C_{20} alkoxy group, a C_3 - C_{20} cycloalkoxy group, a phenyl group, a biphenyl group, a terphenyl group, a naphthyl group, an anthracenyl group, a carbazolyl group, a dibenzofuranyl group, a dibenzothiophenyl group, a pyridinyl group, a pyrazinyl group, a pyrimidinyl group, a pyridazinyl group, and a triazinyl group and $-\text{Si}(\text{Q}_{31})(\text{Q}_{32})(\text{Q}_{33})$, and

[0132] Q_4 to Q_6 and Q_{31} to Q_{33} may each independently be selected from a C_1 - C_{10} alkyl group, a C_1 - C_{10} alkoxy group, a phenyl group, a biphenyl group, a terphenyl group, and a naphthyl group, but embodiments of the present disclosure are not limited thereto.

[0133] b_1 in Formula 1 may be an integer from 1 to 10. b_1 indicates the number of $^*-(\text{L}_1)_{a1}-\text{R}_1(\text{s})$, wherein, when b_1 is two or more, two or more $^*-(\text{L}_1)_{a1}-\text{R}_1(\text{s})$ may be identical or different from each other.

[0134] In one embodiment, b_1 may be an integer from 1 to 5.

[0135] In one or more embodiments, b_1 may be 1, 2, or 3.

[0136] In one or more embodiments, b_1 may be 1 or 2, but embodiments of the present disclosure are not limited thereto.

[0137] b_2 in Formula 1 may be an integer from 1 to 10. b_2 indicates the number of $^*-(\text{L}_2)_{a2}-\text{R}_2(\text{s})$, wherein, when b_2 is two or more, two or more $^*-(\text{L}_2)_{a2}-\text{R}_2(\text{s})$ may be identical or different from each other.

[0138] In one embodiment, b_2 may be an integer from 1 to 5.

[0139] In one or more embodiments, b_2 may be 1, 2, or 3.

[0140] In one or more embodiments, b_2 may be 1 or 2, but embodiments of the present disclosure are not limited thereto.

[0141] b_4 in Formula 2-1 may be an integer from 0 to 5. b_4 indicates the number of $^*-(\text{L}_4)_{a4}-\text{R}_4(\text{s})$, wherein, when b_4 is two or more, two or more $^*-(\text{L}_4)_{a4}-\text{R}_4(\text{s})$ may be identical or different from each other.

[0142] In one embodiment, b_4 may be 0, 1, or 2.

[0143] In one or more embodiments, b_4 may be 0 or 1, but embodiments of the present disclosure are not limited thereto.

[0144] b_5 in Formula 2-2 may be an integer from 0 to 6. b_5 indicates the number of $^*-(\text{L}_5)_{a5}-\text{R}_5(\text{s})$, wherein, when b_5 is two or more, two or more $^*-(\text{L}_5)_{a5}-\text{R}_5(\text{s})$ may be identical or different from each other.

[0145] In one embodiment, b_5 may be 0, 1, 2, or 3.

[0146] In one or more embodiments, b_5 may be 0, 1, or 2, but embodiments of the present disclosure are not limited thereto.

[0147] In one embodiment, the first compound may be represented by one of Formulae 1A to 1P:

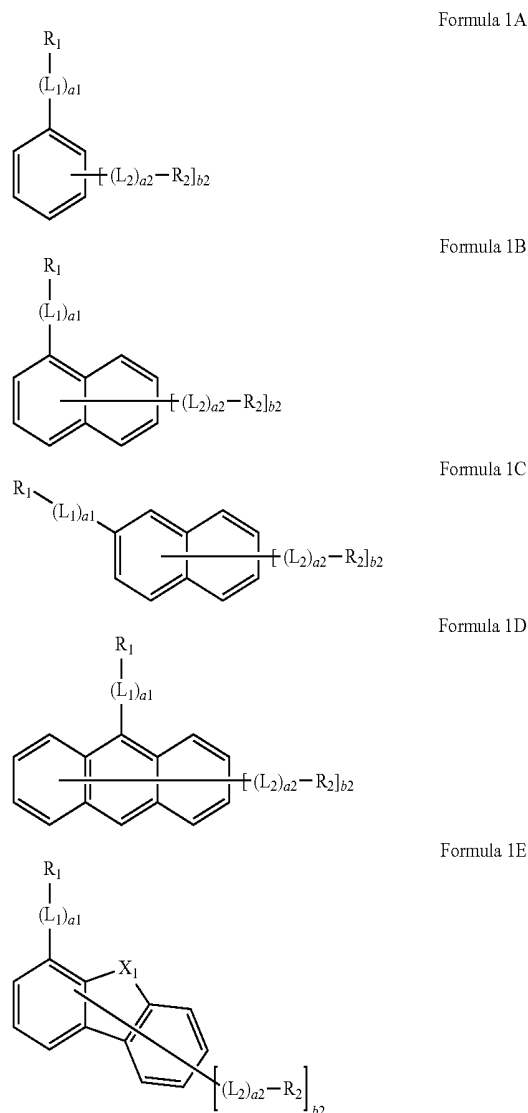

-continued

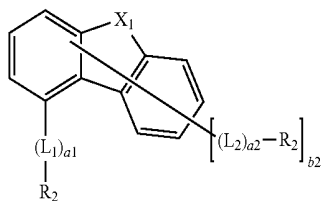

Formula 1F

-continued

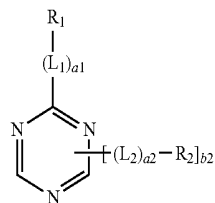

Formula 1L

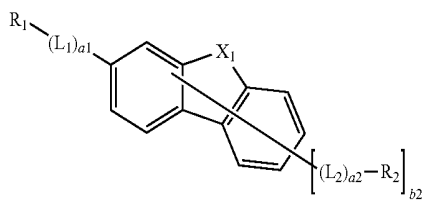

Formula 1G

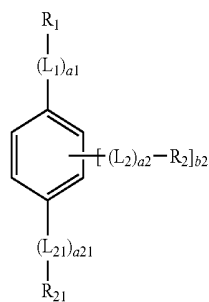

Formula 1M

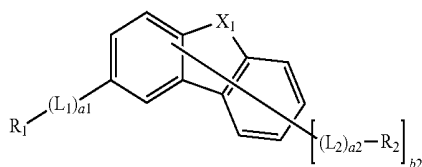

Formula 1H

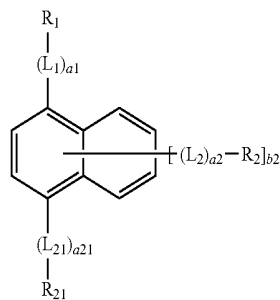

Formula 1N

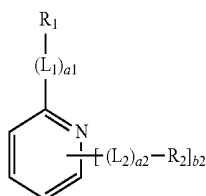

Formula 1I

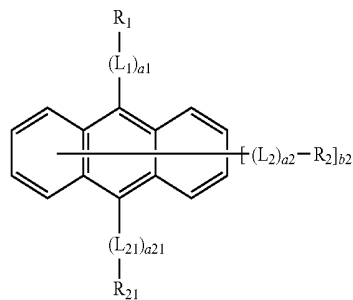

Formula 1O

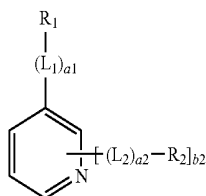

Formula 1J

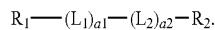

Formula 1P

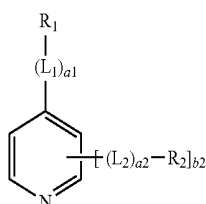

Formula 1K

[0148] In Formulae 1A to 1P, L_1 , L_2 , a_1 , a_2 , R_1 , R_2 , and b_2 are the same as described herein in connection with Formula 1, and L_{21} , a_{21} , and R_{21} are the same as described in connection with L_1 , a_1 , and R_1 , respectively.

[0149] For example, L_1 , L_2 , and L_{21} in Formula 1A to 1P may each independently be selected from $^* - S - ^*$, $^* - O - ^*$, $^* - C(=O) - ^*$, $^* - S(=O) - ^*$, $^* - S(=O)_2 - ^*$, $^* - [C(Z_1)(Z_2)]_{n1} - ^*$, and groups represented by Formulae 3-1 to 3-75.

[0150] In one or more embodiments, L_1 , L_2 , and L_{21} in Formulae 1A to 1P may each independently be selected from $^* - O - ^*$, $^* - C(=O) - ^*$, $^* - CH_2 - ^*$, $^* - (CH_2)_2 - ^*$, $^* - (CH_2)_3 - ^*$, $^* - (CH_2)_4 - ^*$, $^* - (CH_2)_5 - ^*$, and groups represented by Formulae 4-1 to 4-58 and 4-60.

[0151] In one or more embodiments, R_1 and R_{21} in Formulae 1A to 1P may each independently be a group represented by Formula 2-1A or a group represented by Formula 2-2.

[0152] In one or more embodiments, R_1 and R_{21} in Formulae 1M to 1O may each be a group represented by Formula 2-1. For example, R_1 and R_{21} in Formulae 1M to 1O may each be a group represented by Formula 2-1A.

[0153] In one or more embodiments, R_1 and R_{21} in Formulae 1M to 1O may each be a group represented by Formula 2-2.

[0154] The first compound may be one of Compounds 1 to 205, but embodiments of the present disclosure are not limited thereto:

-continued

3

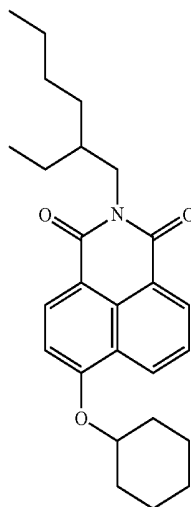

1

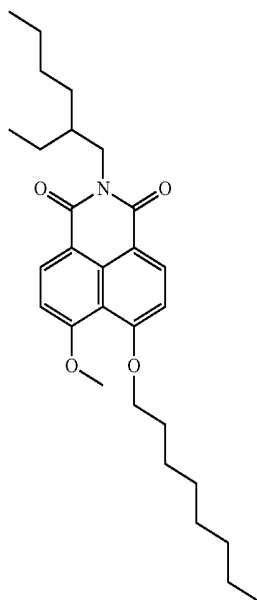

2

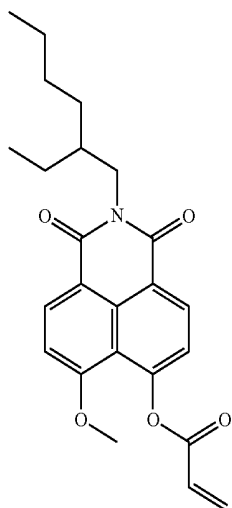

4

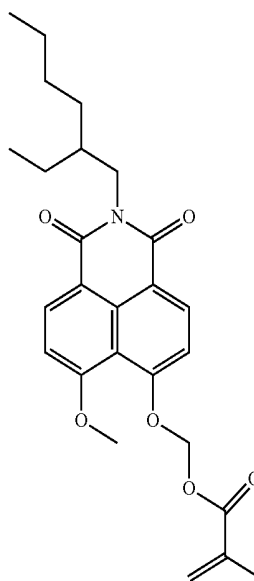

5

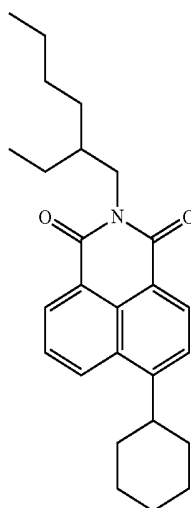

-continued

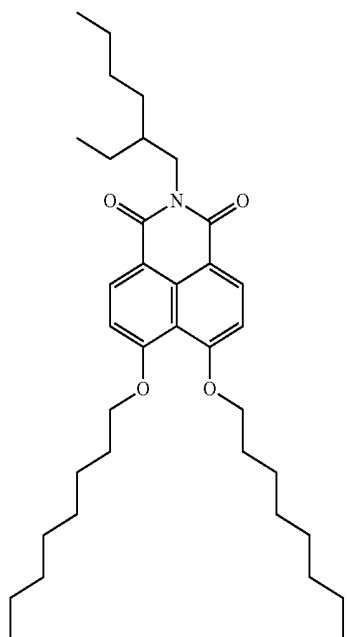

6

-continued

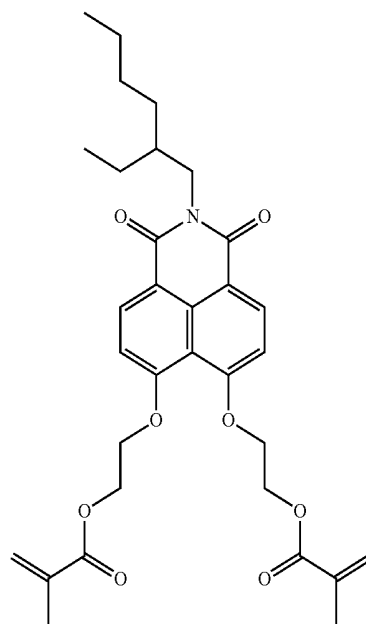

9

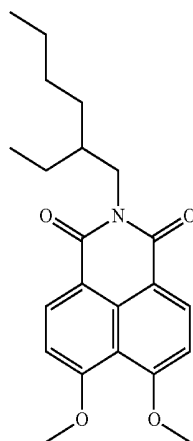

7

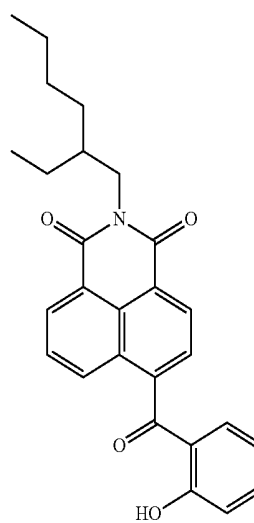

10

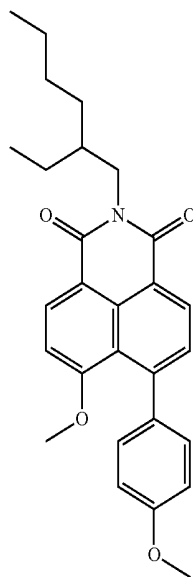

8

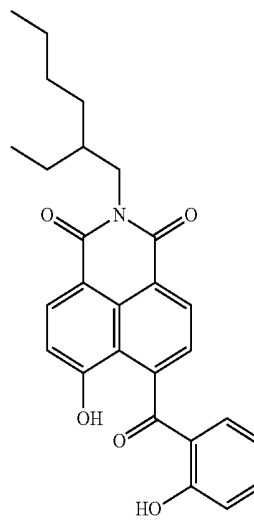

11

-continued

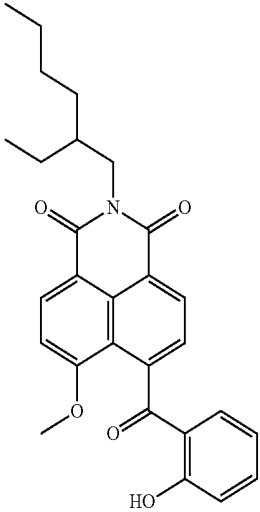

12

-continued

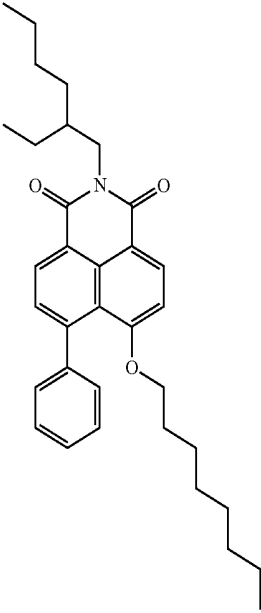

14

13

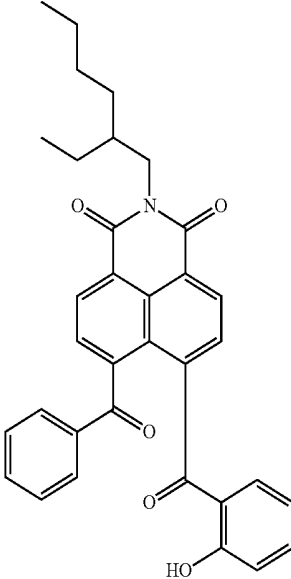

15

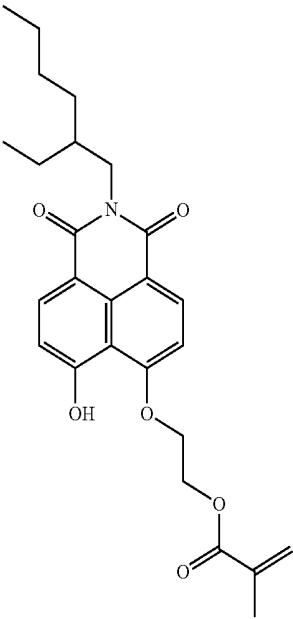

-continued

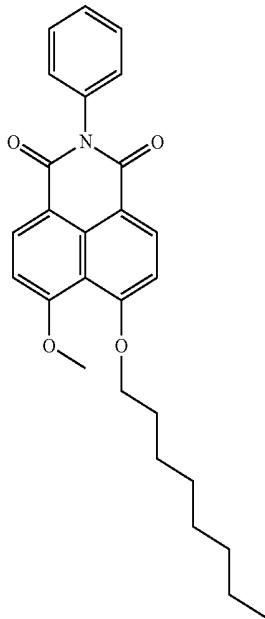

16

-continued

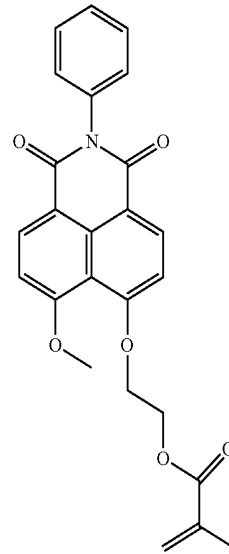

19

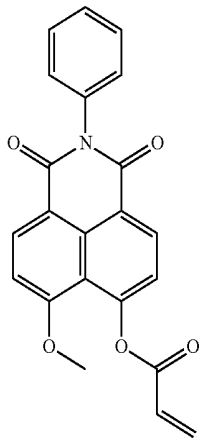

17

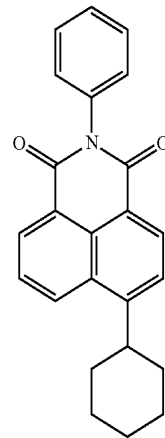

20

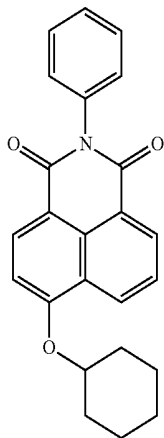

18

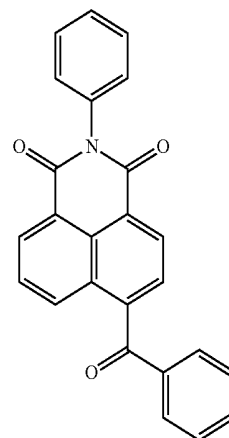

21

-continued

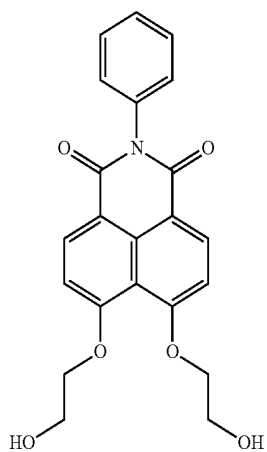
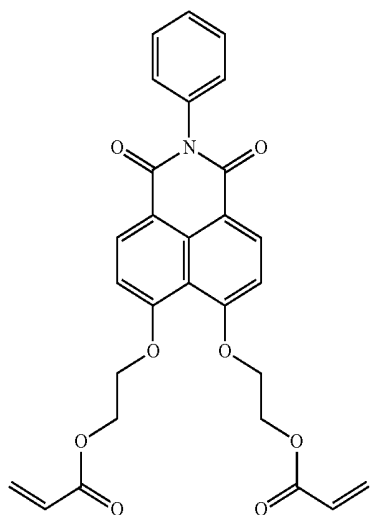
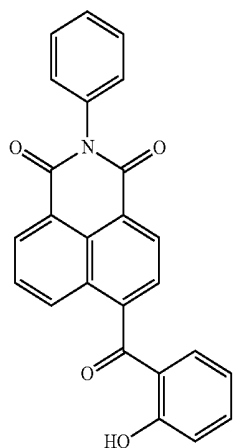

-continued

22

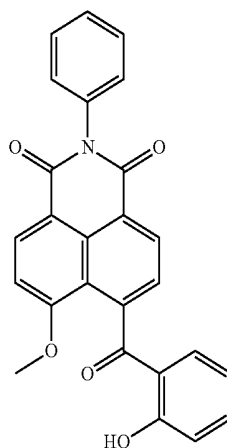

25

23

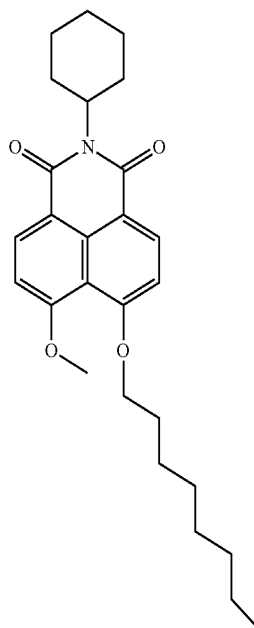

26

24

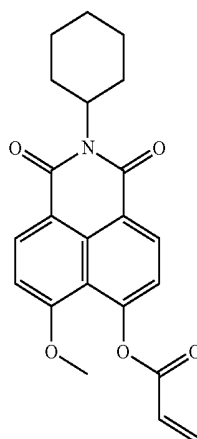

27

-continued

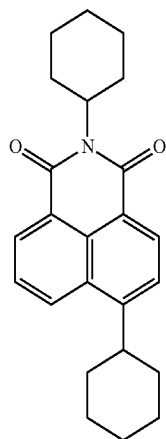
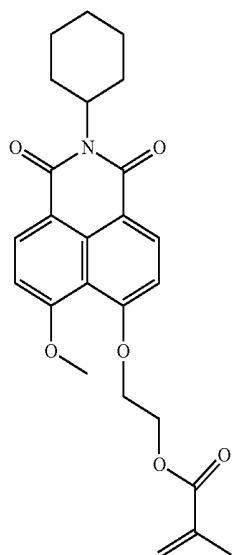
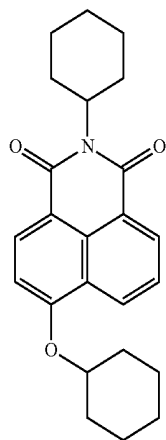

-continued

28

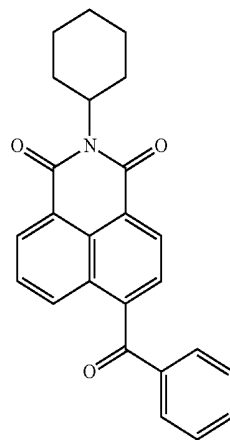

31

29

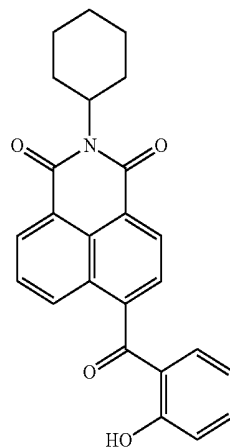

32

30

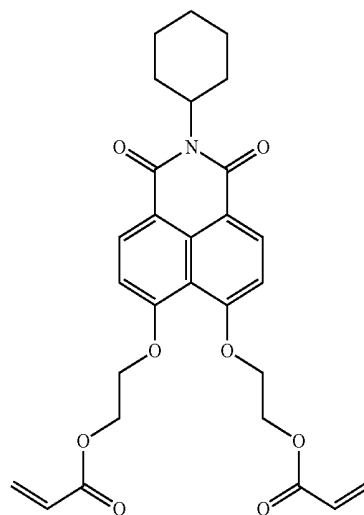

33

-continued

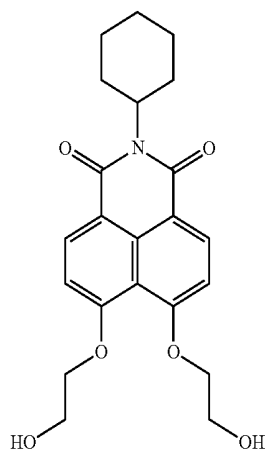

34

-continued

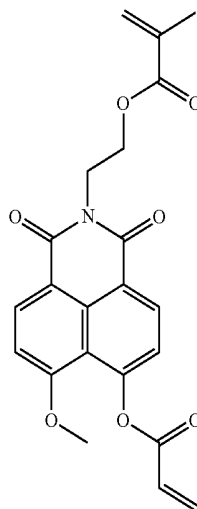

35

37

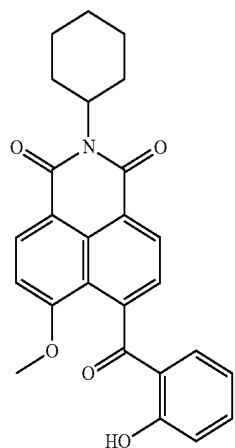

36

38

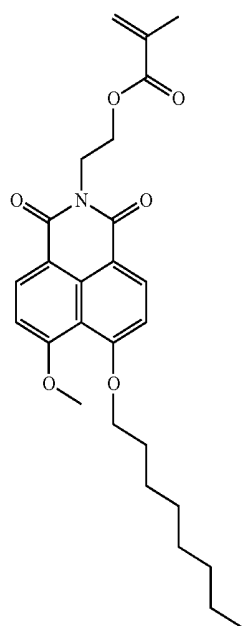

39

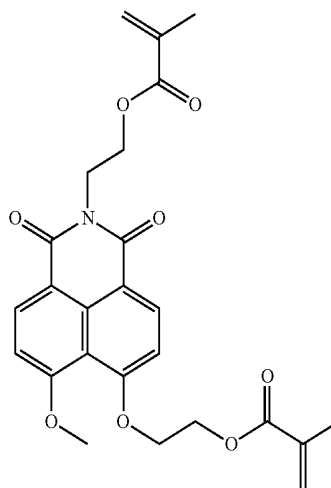

-continued

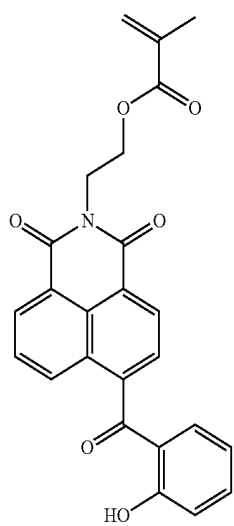
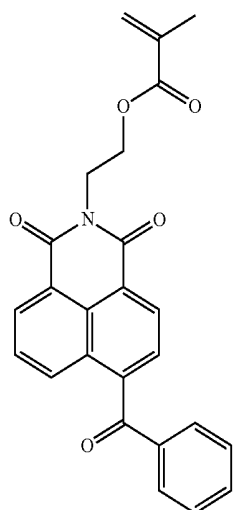
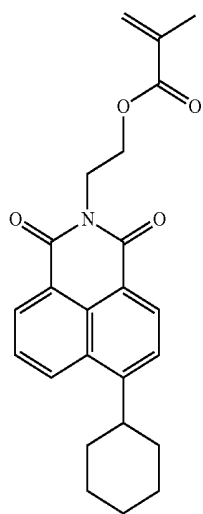

-continued

40

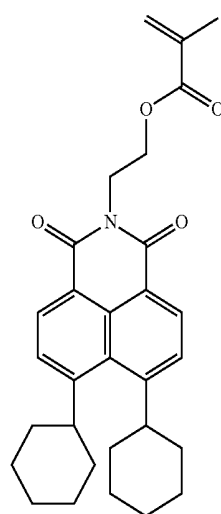

43

41

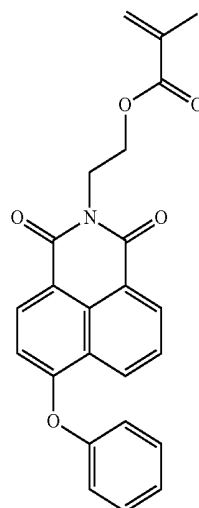

44

42

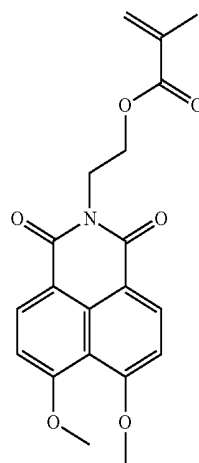

45

-continued

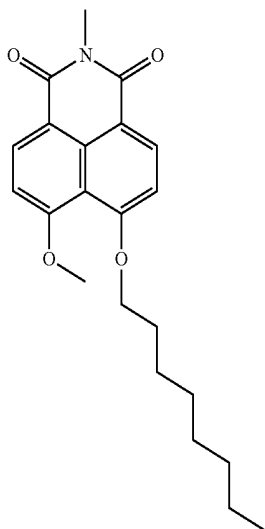

46

-continued

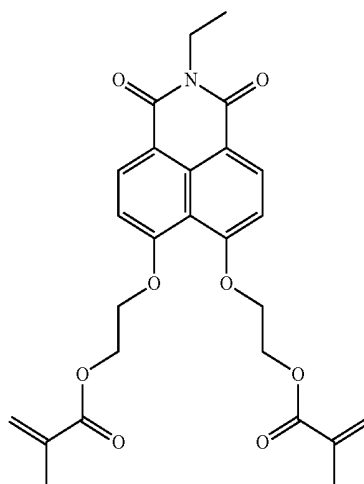

49

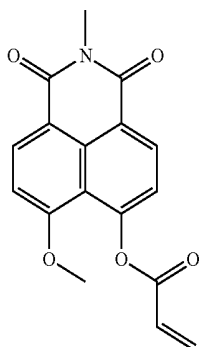

47

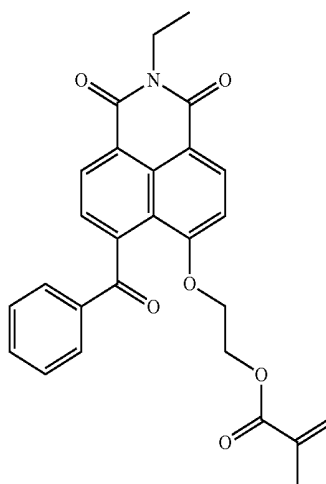

50

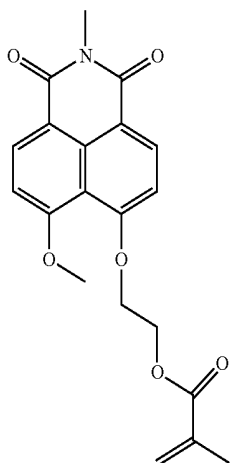

48

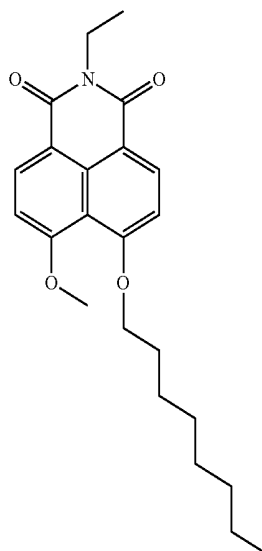

51

-continued

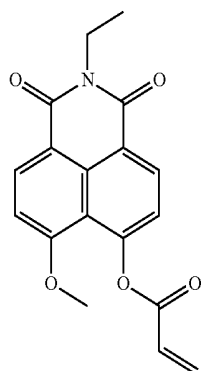

52

-continued

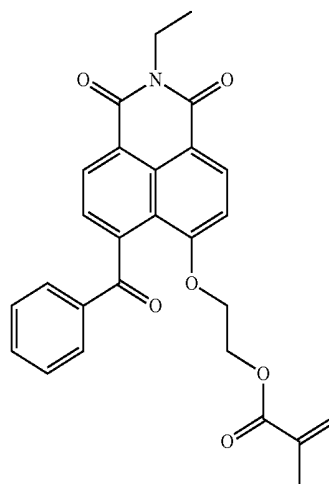

55

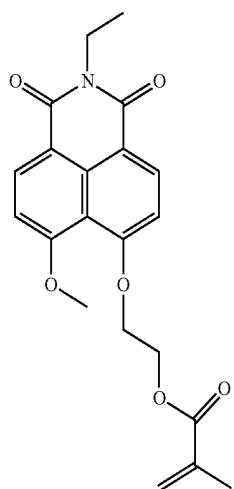

53

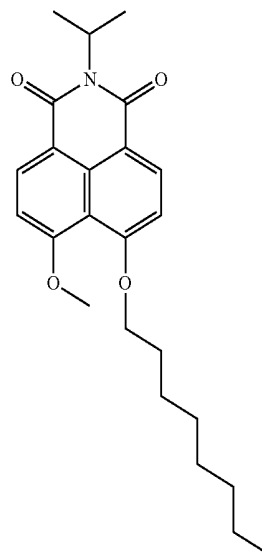

56

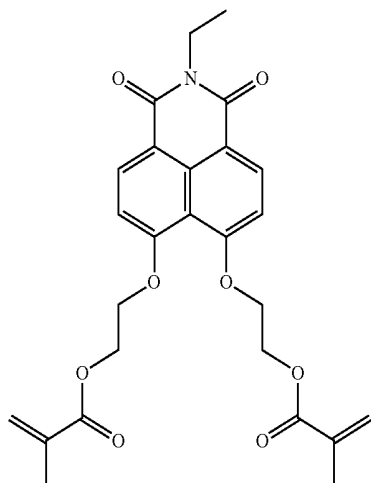

54

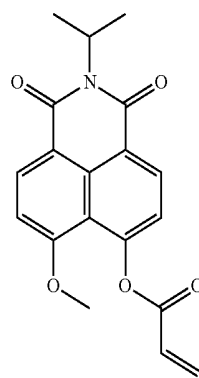

57

-continued

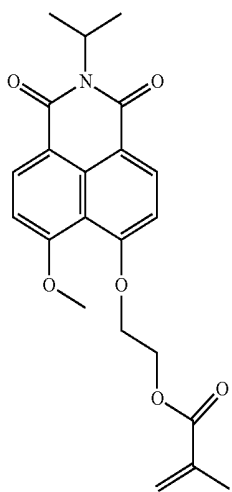

58

-continued

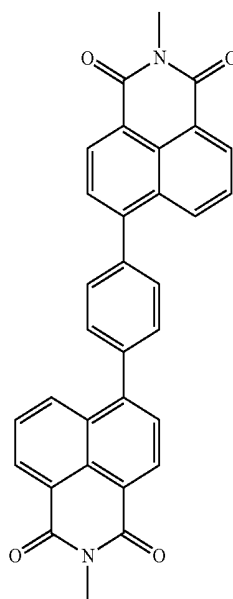

59

61

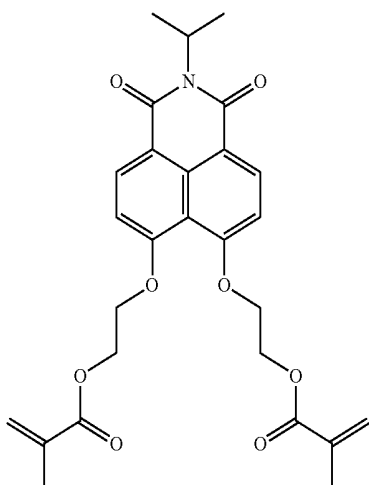

60

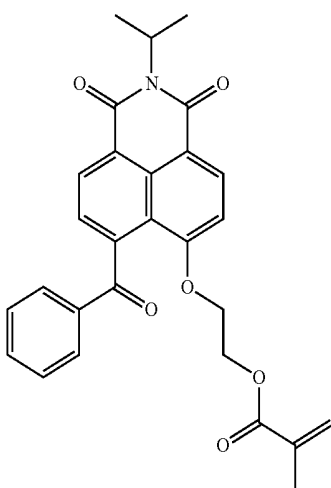

62

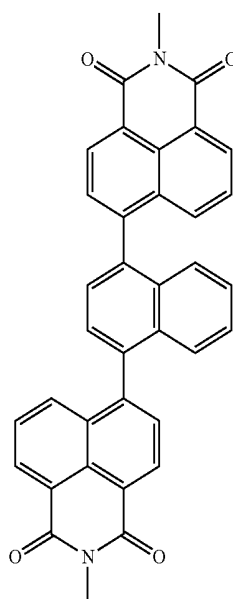

-continued

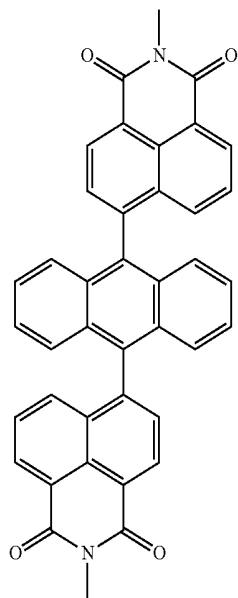

63

-continued

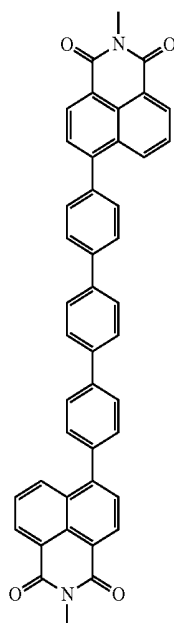

65

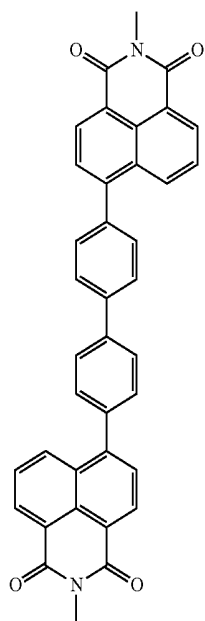

64

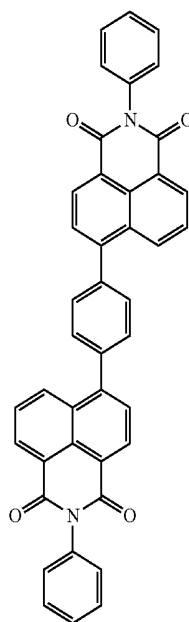

66

-continued

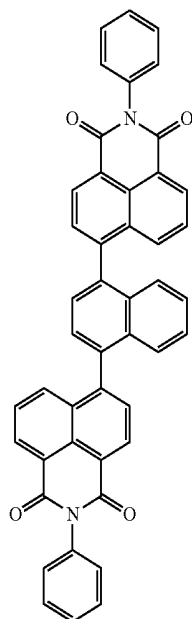

67

-continued

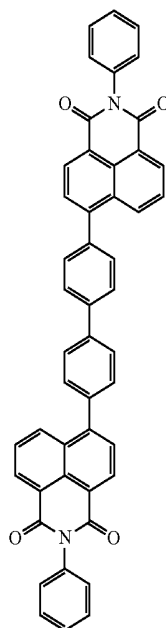

69

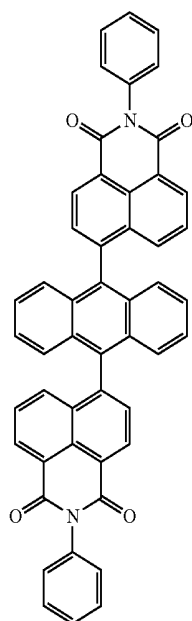

68

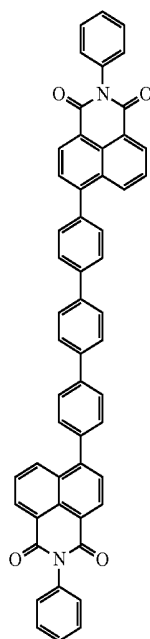

70

-continued

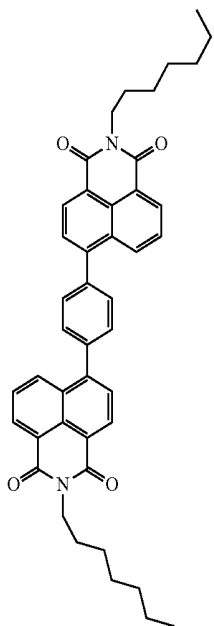

71

-continued

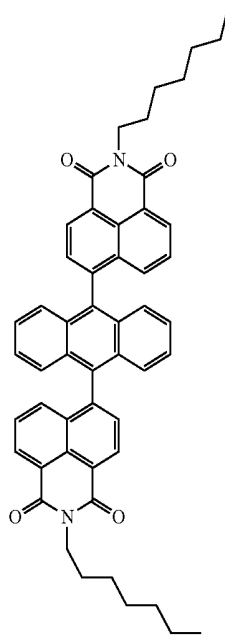

73

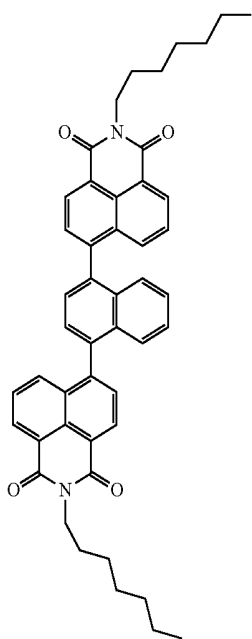

72

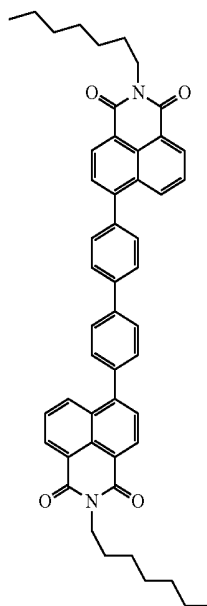

74

-continued

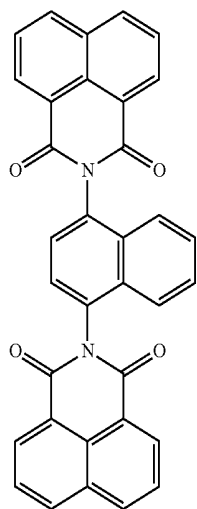
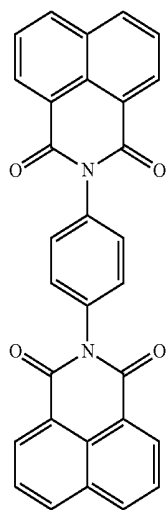
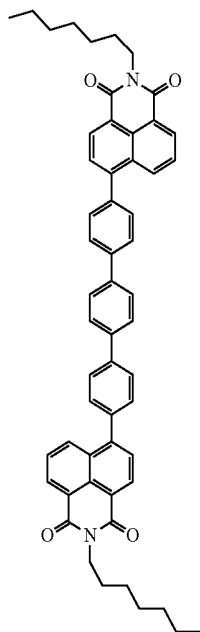

-continued

75

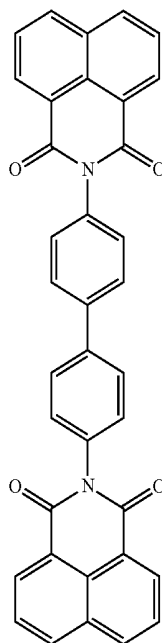

78

76

77

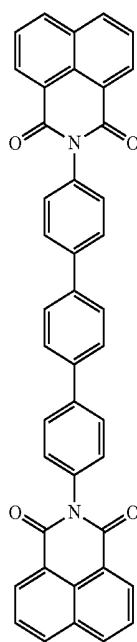

79

-continued

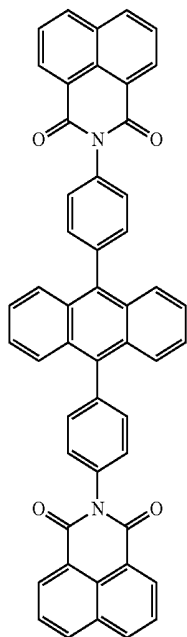

80

-continued

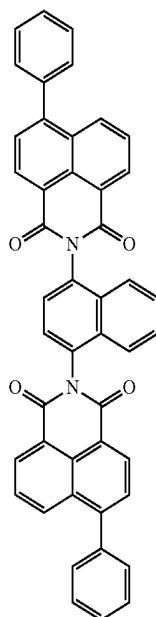

82

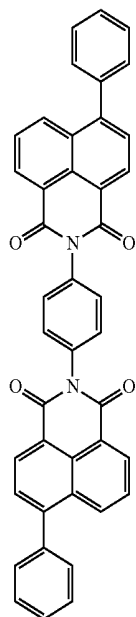

81

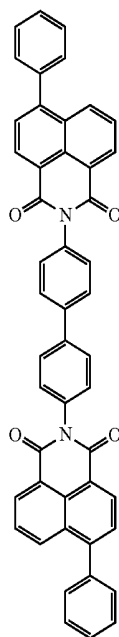

83

-continued

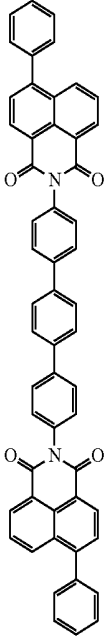

84

-continued

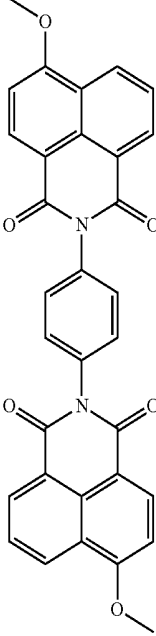

86

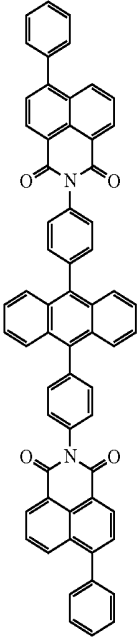

85

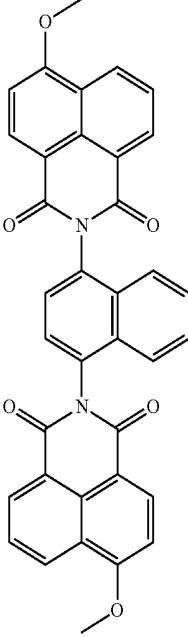

87

-continued

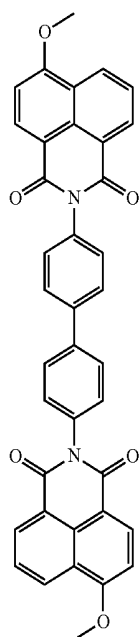

88

-continued

90

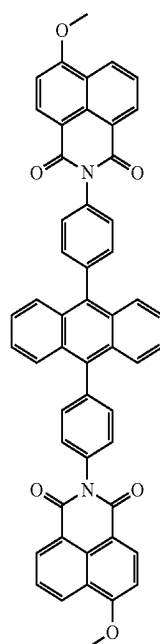

89

91

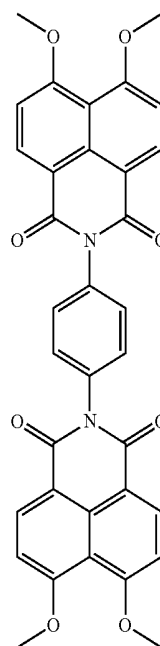
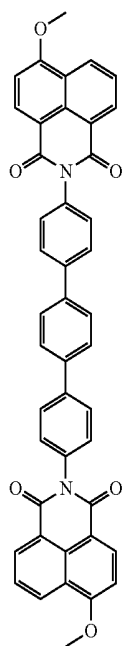

-continued

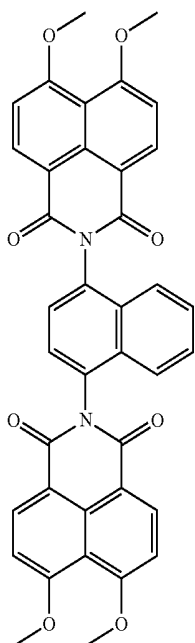

92

-continued

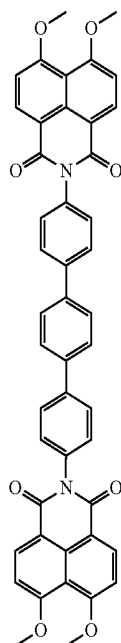

94

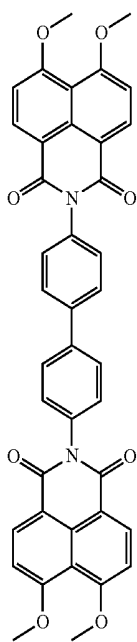

93

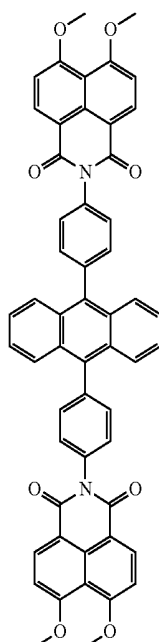

95

-continued

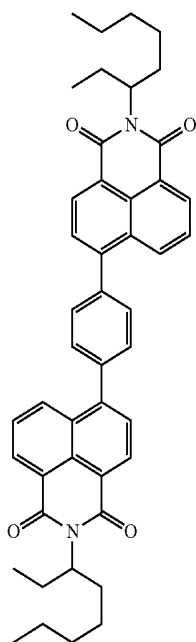

96

-continued

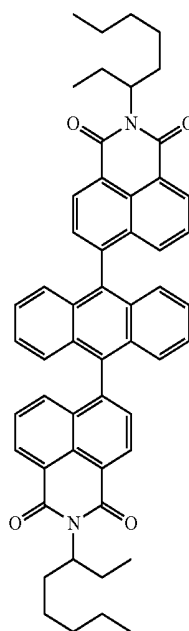

98

97

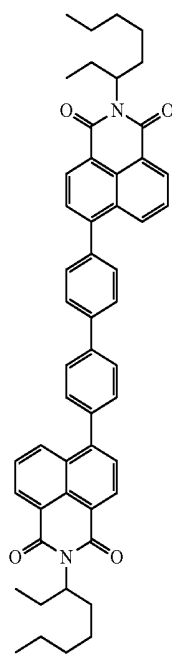
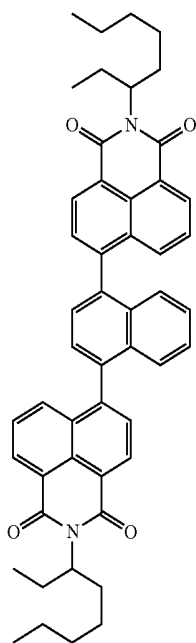

99

-continued

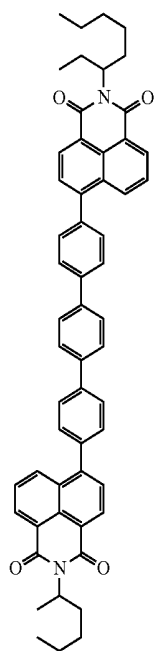

100

-continued

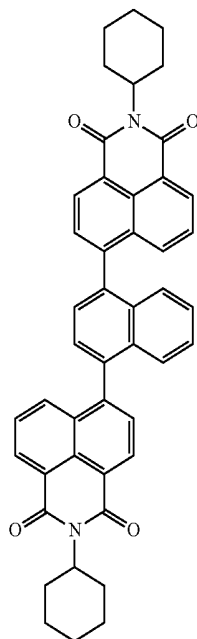

102

101

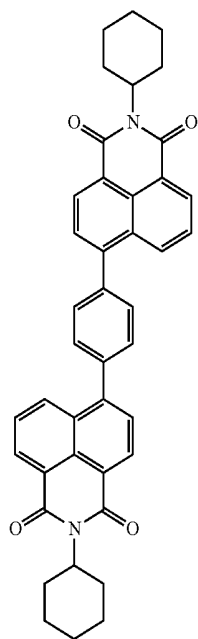

103

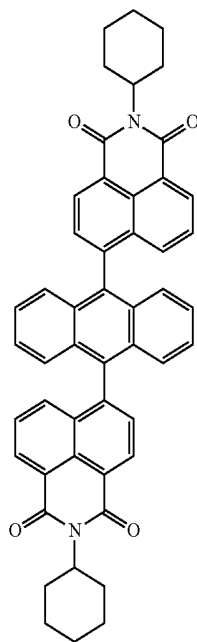

-continued

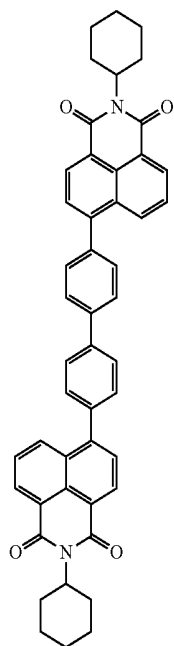

104

-continued

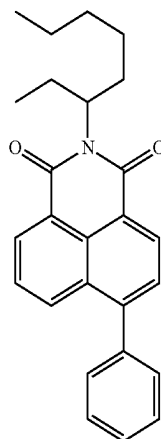

106

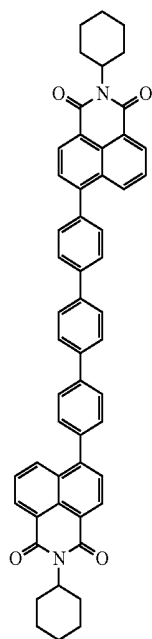

105

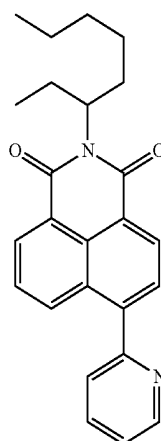

107

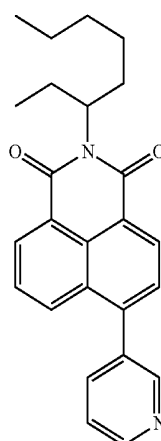

108

-continued

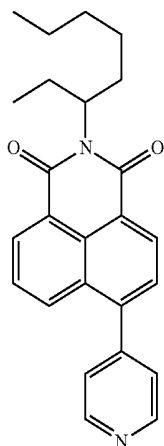

109

-continued

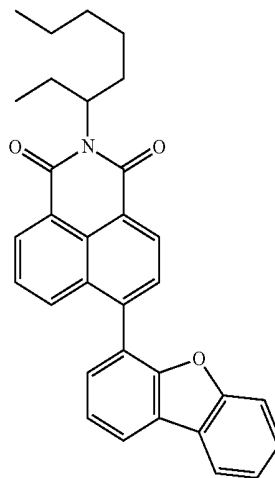

112

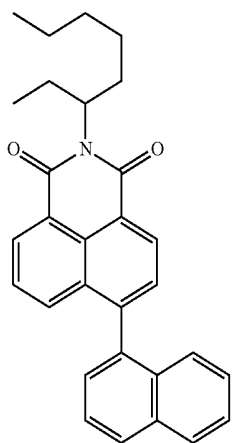

110

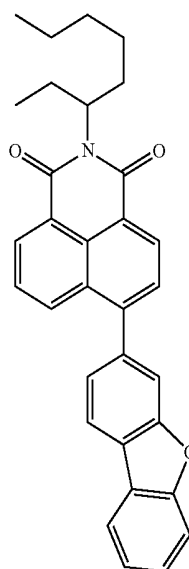

113

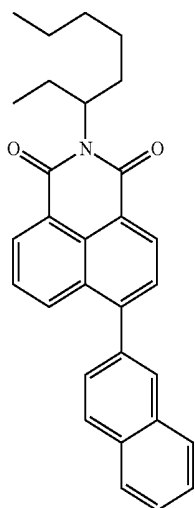

111

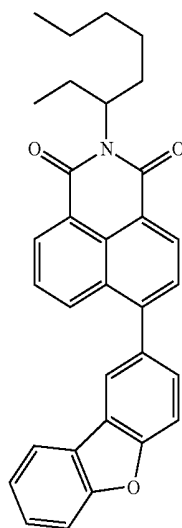

114

-continued

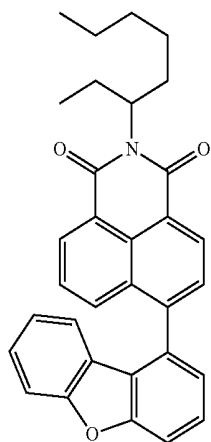

115

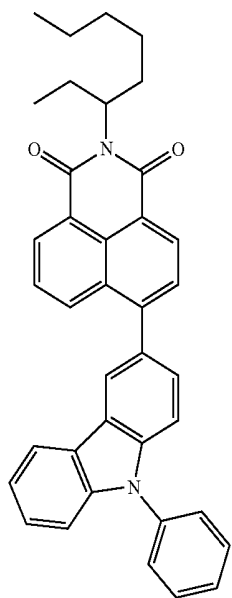

116

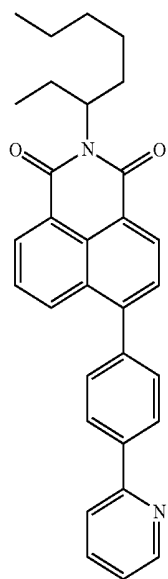

117

-continued

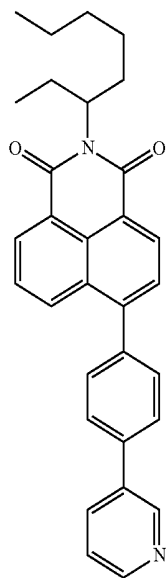

118

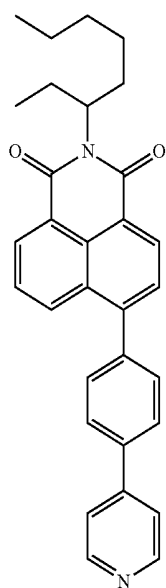

119

-continued

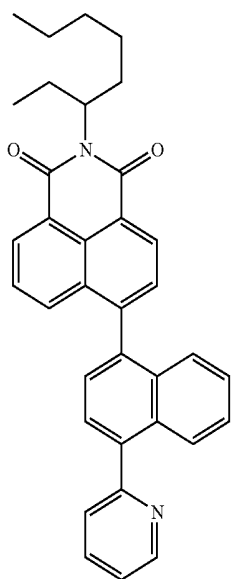

120

-continued

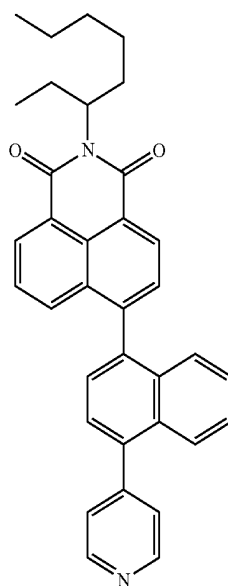

122

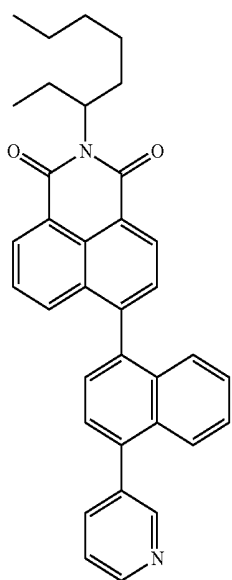

121

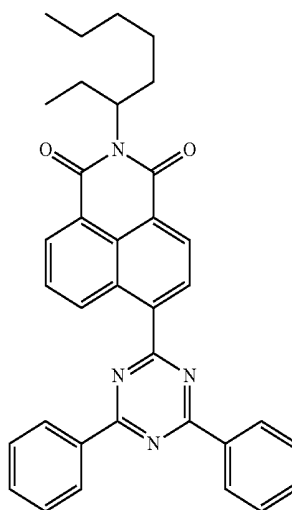

123

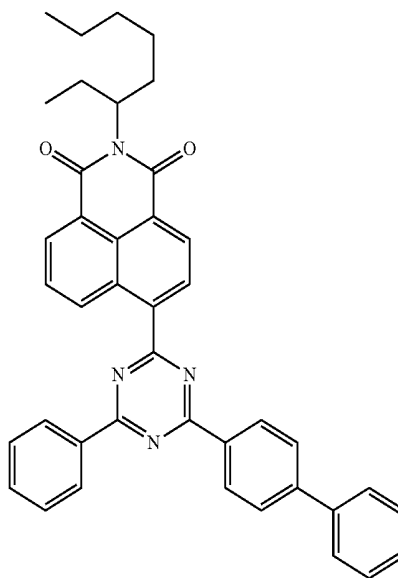

124

-continued

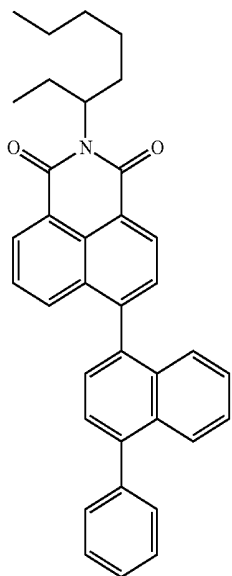

125

-continued

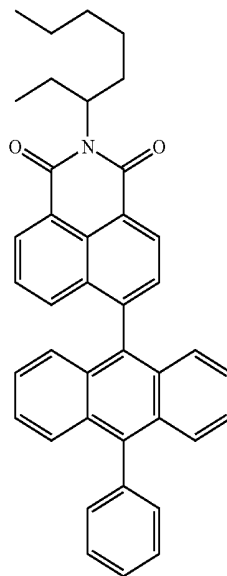

127

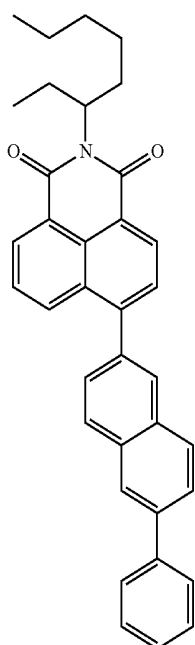

126

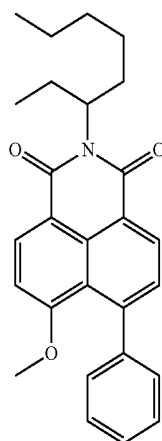

128

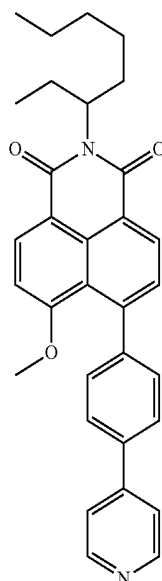

129

-continued

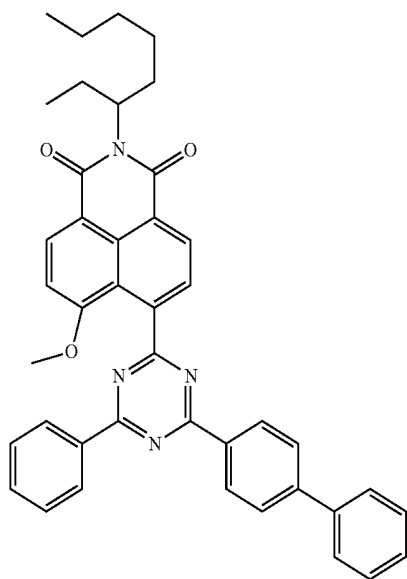

130

-continued

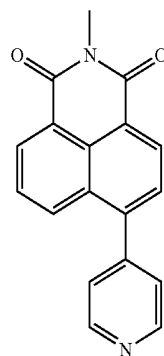

134

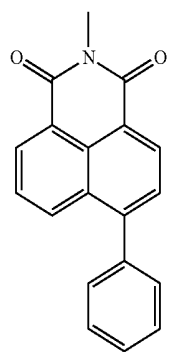

131

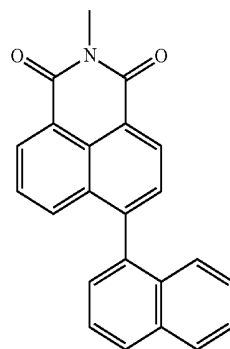

135

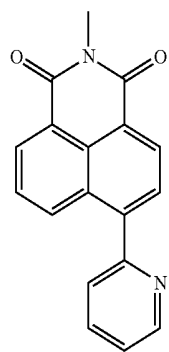

132

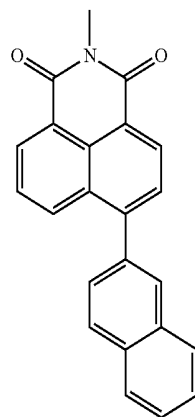

136

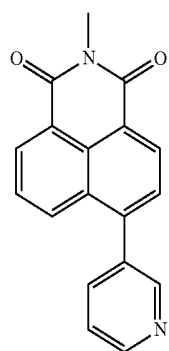

133

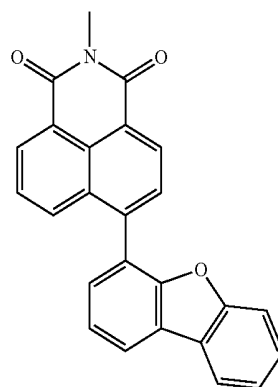

137

-continued

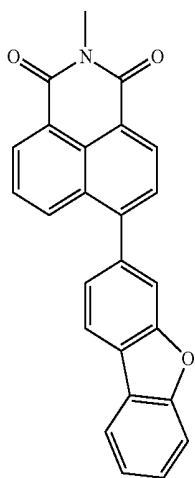

138

-continued

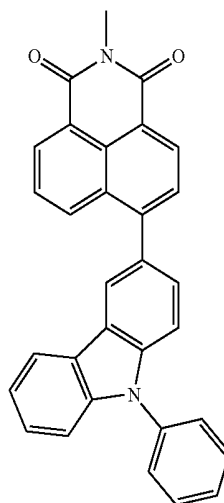

141

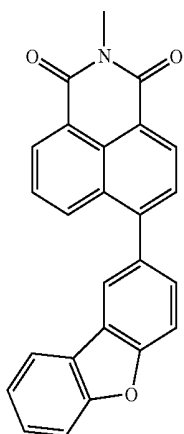

139

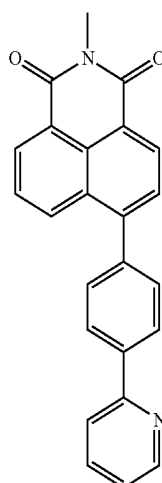

142

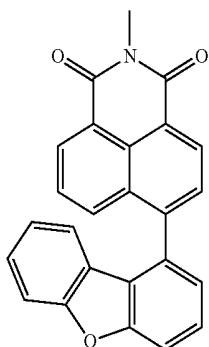

140

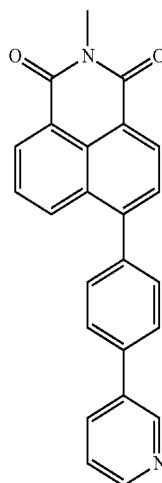

143

-continued

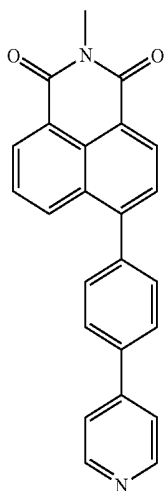

144

-continued

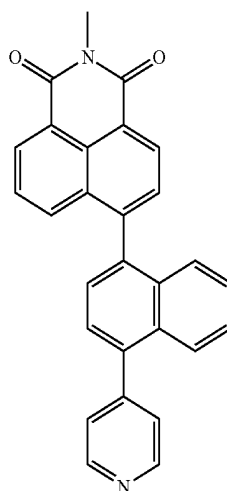

147

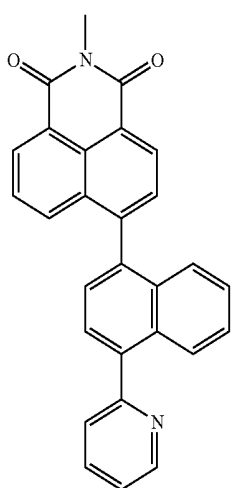

145

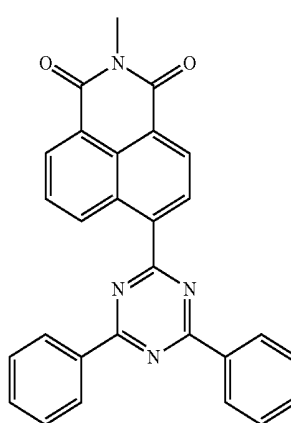

148

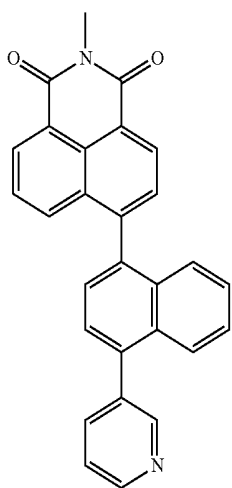

146

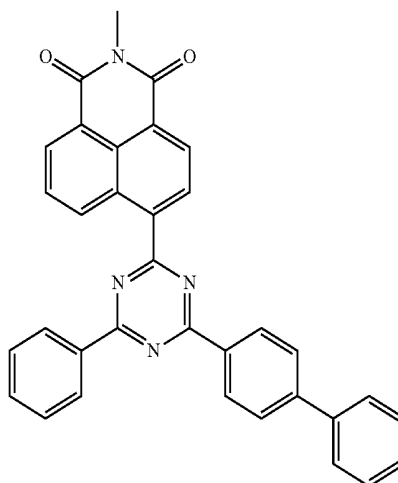

149

-continued

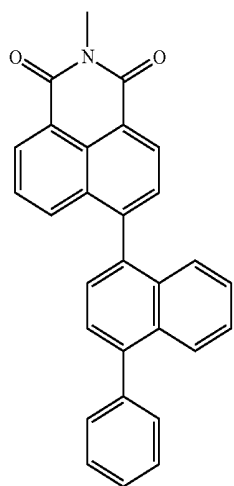

150

-continued

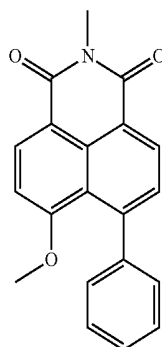

153

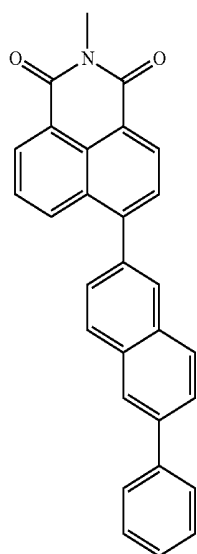

151

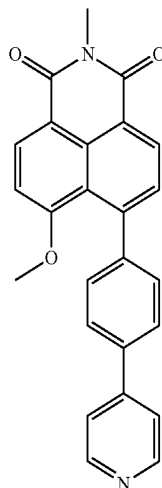

154

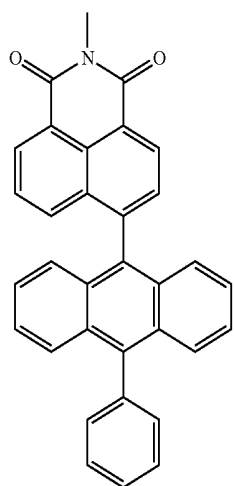

152

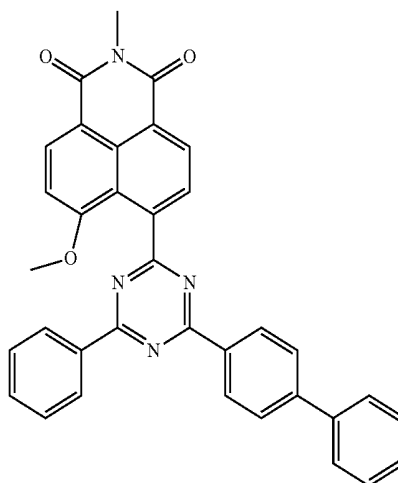

155

-continued

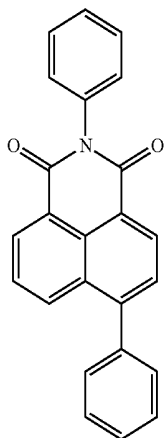

156

-continued

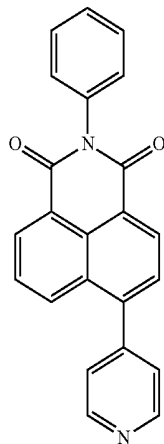

159

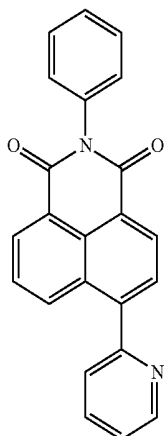

157

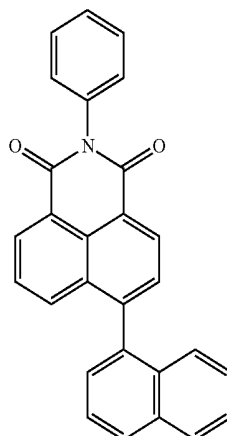

160

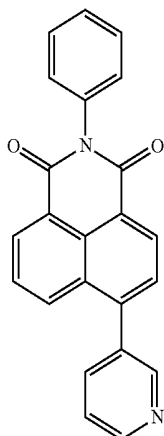

158

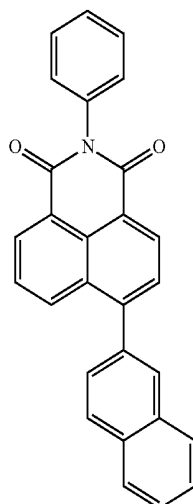

161

-continued

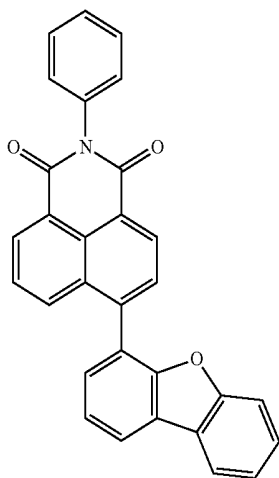

162

-continued

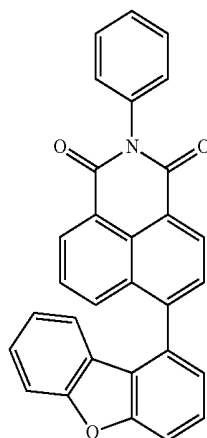

165

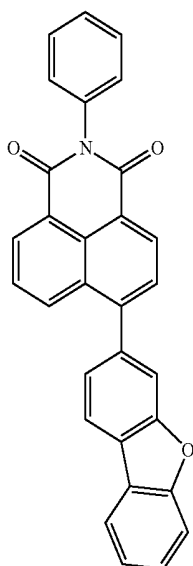

163

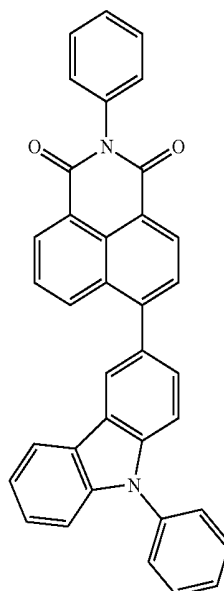

166

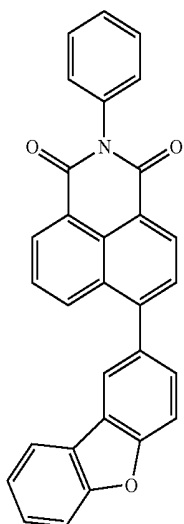

164

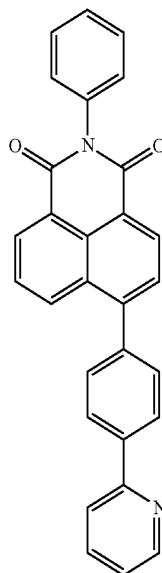

167

-continued

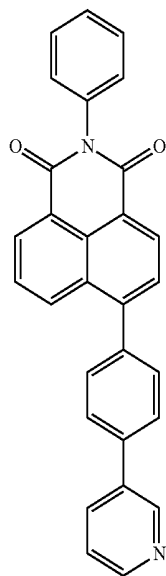

168

-continued

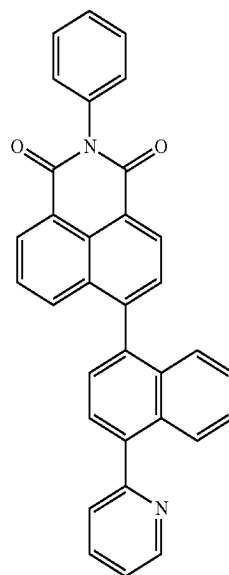

170

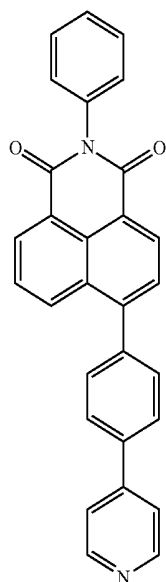

169

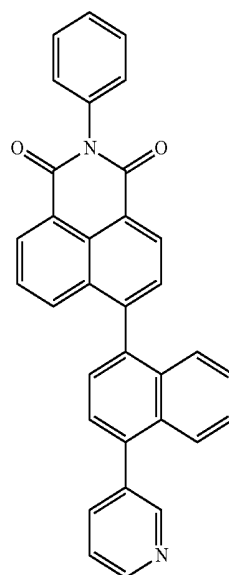

171

-continued

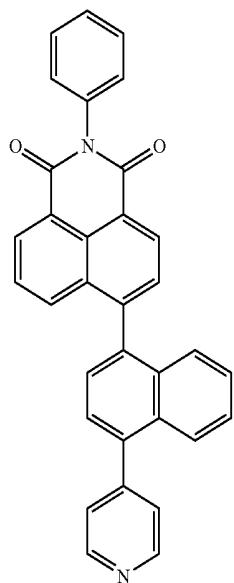

172

-continued

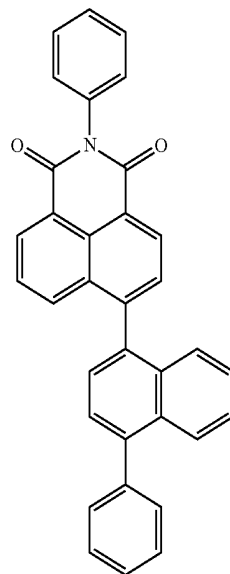

175

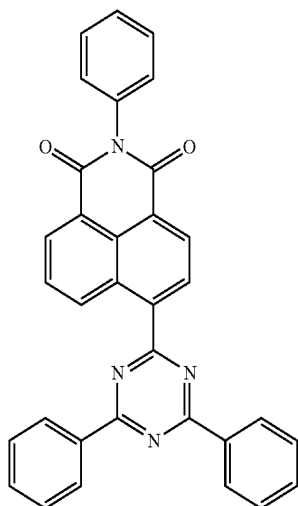

173

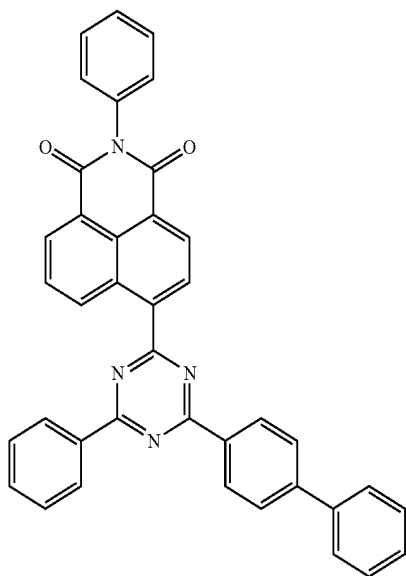

174

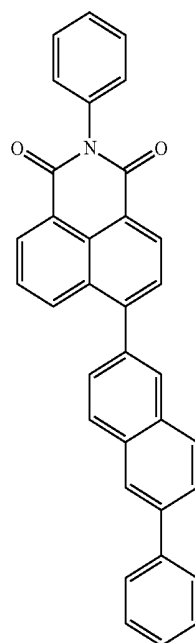

176

-continued

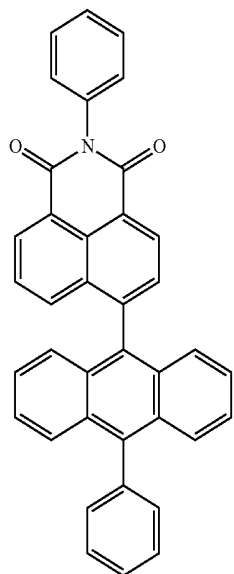

177

-continued

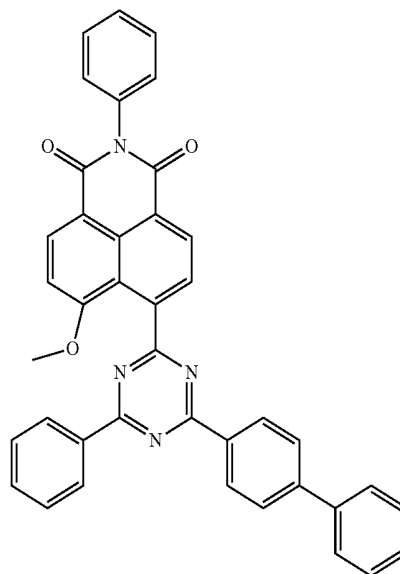

180

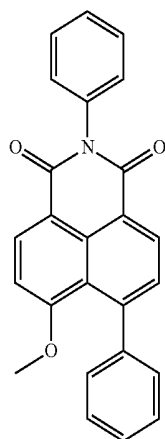

178

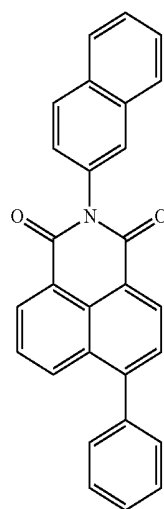

181

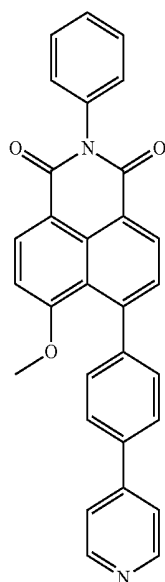

179

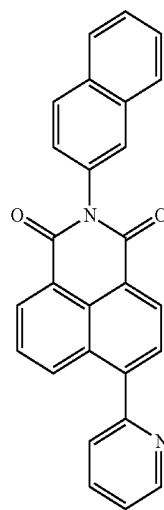

182

-continued

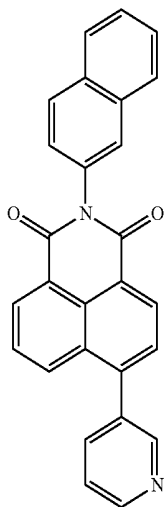

183

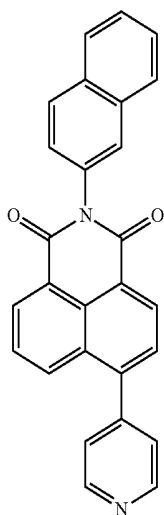

184

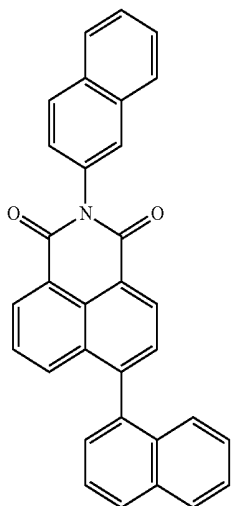

185

-continued

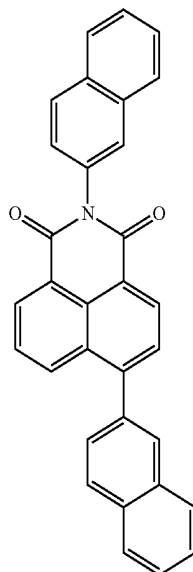

186

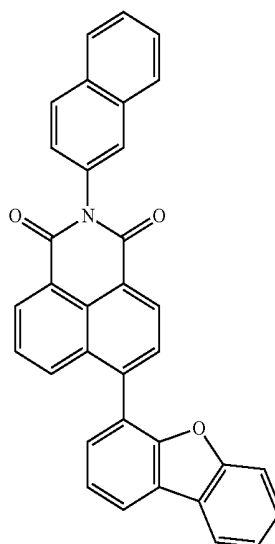

187

-continued

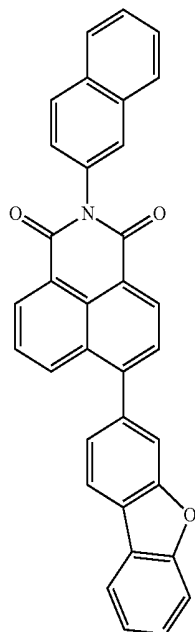

188

-continued

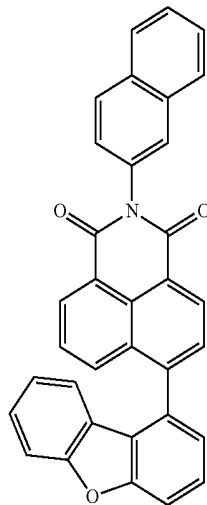

190

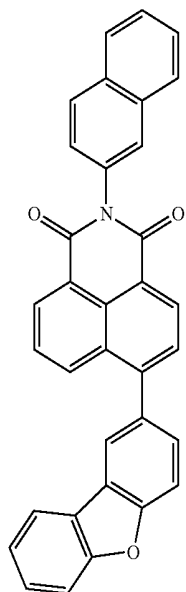

189

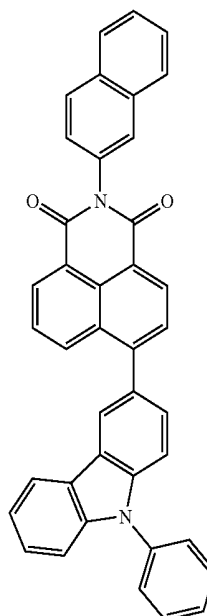

191

-continued

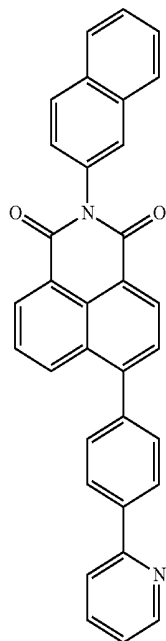

192

-continued

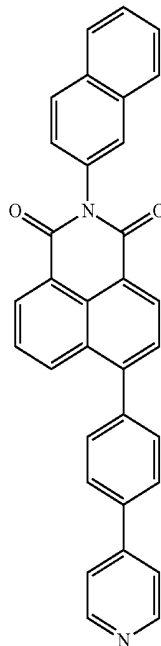

194

193

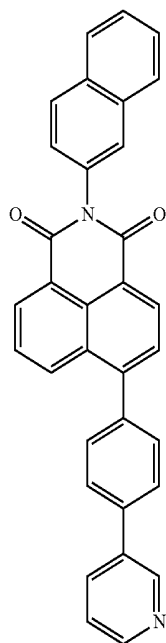

195

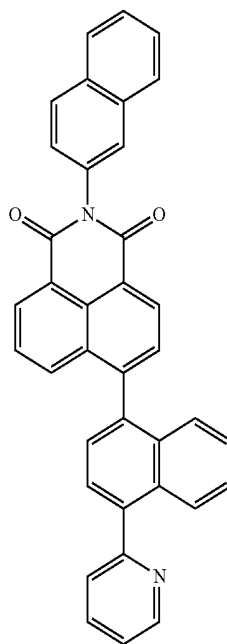

-continued

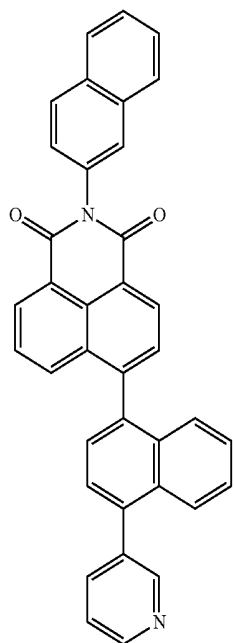

196

-continued

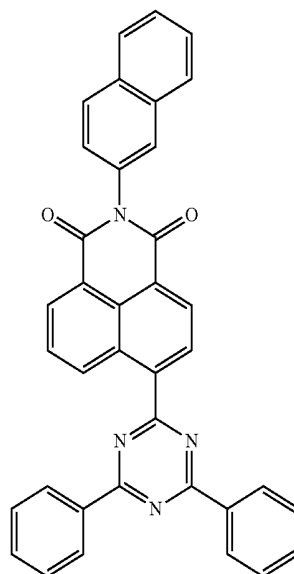

198

197

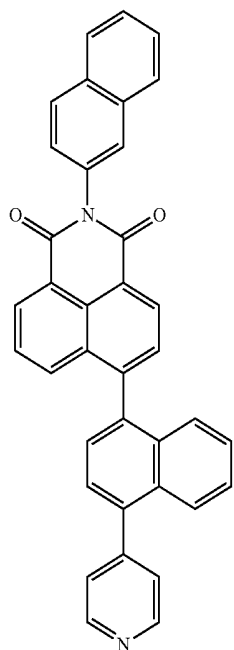

199

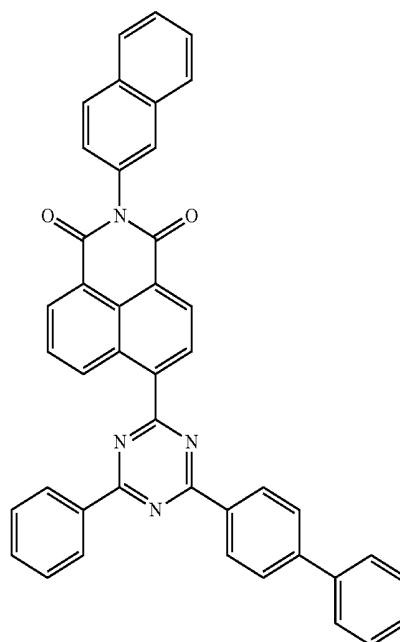

-continued

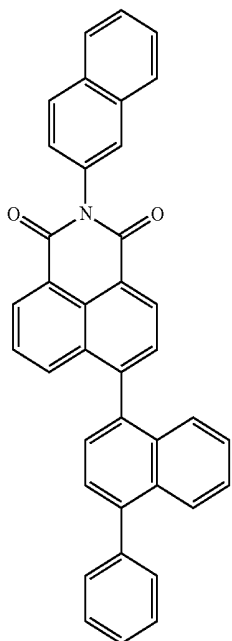

200

-continued

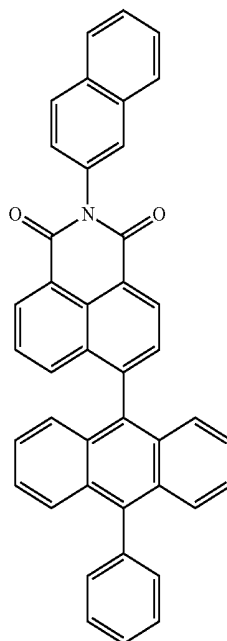

202

201

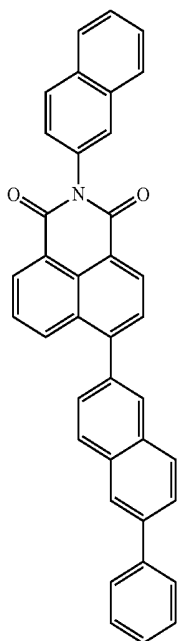

203

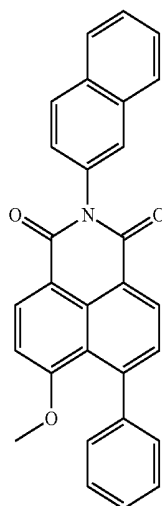

-continued

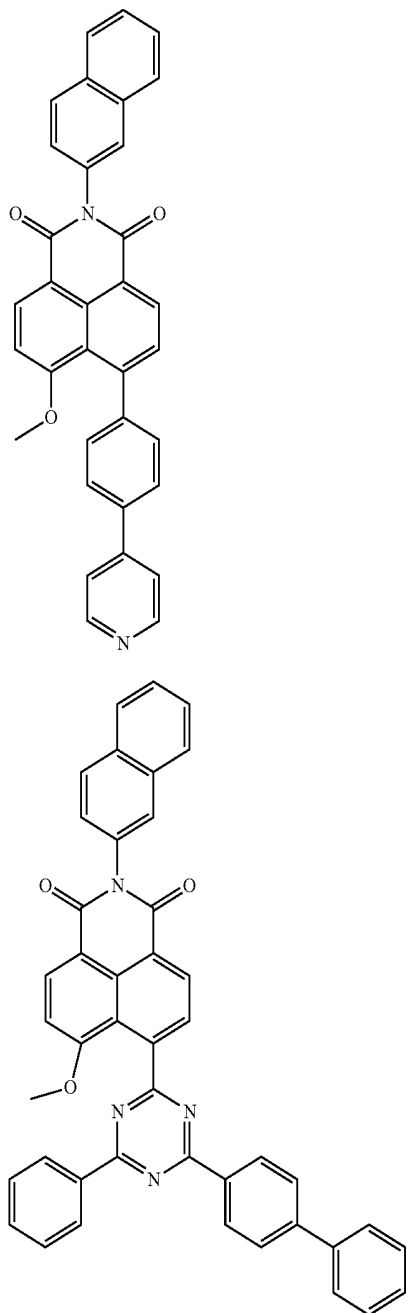

[0155] The first compound absorbs ultraviolet rays to prevent or substantially prevent the ultraviolet rays from transmitting through the organic light-emitting device **200**. Therefore, the organic light-emitting display apparatus **10**, in which the first compound is included in the encapsulation unit **300**, may prevent or substantially prevent the emission layer, the insulating film, and/or the like (including the organic material) from being damaged by the ultraviolet rays. For example, the first compound may absorb light having a wavelength of about 400 nm to about 410 nm.

[0156] In one embodiment, a first compound solution in a solvent (e.g., the first compound dissolved in a solvent, for example, toluene) has a transmittance of about 10% or less

(for example, about 8% or less) with respect to light having a wavelength of about 400 nm to about 410 nm (for example, about 405 nm).

[0157] In one or more embodiments, the first compound solution in the solvent (for example, toluene) has a transmittance of about 20% or more (for example, about 25% or more) with respect to light having a wavelength of about 425 nm to about 435 nm (for example, about 430 nm).

[0158] In one embodiment, the encapsulation unit **300** may further include a second compound that is different from the first compound, and a wavelength range of light absorbed by the first compound may be different from a wavelength range of light absorbed by the second compound.

[0159] For example, the second compound may include one selected from a benzophenone-based compound, a benzotriazole-based compound, a benzoate-based compound, a cyanoacrylate-based compound, a triazine-based compound, an oxanilide-based compound, and a salicylate-based compound.

[0160] The benzophenone-based compound may include, for example, 2,4-dihydroxybenzophenone, 2-hydroxy-4-methoxybenzophenone, 2-hydroxy-4-octylbenzophenone, 4-dodecyloxy-2-hydroxybenzophenone, 4-benzyloxy-2-hydroxybenzophenone, 2,2',4,4'-tetrahydroxybenzophenone, and 2,2'-dihydroxy-4,4'-dimethoxybenzophenone.

[0161] The benzotriazole-based compound may include, for example, 2-(5-methyl-2-hydroxyphenyl)benzotriazole, 2-[2-hydroxy-3,5-bis(α,α -dimethylbenzyl)phenyl]-2H-benzotriazole, 2-(3,5-di-*t*-butyl-2-hydroxyphenyl)benzotriazole, 2-(3-*t*-butyl-5-methyl-2-hydroxyphenyl)-5-chlorobenzotriazole, 2-(3,5-di-*t*-butyl-2-hydroxyphenyl)-5-chlorobenzotriazole, 2-(3,5-di-*t*-acyl-2-hydroxyphenyl)benzotriazole, and 2-(2'-hydroxy-5'-*t*-octylphenyl)benzotriazole.

[0162] The benzoate-based compound may include, for example, 2,4-di-*t*-butylphenyl-3',5'-di-*t*-butyl-4-hydroxybenzoate.

[0163] The triazine-based compound may include, for example, 2-[4-[(2-hydroxy-3-dodecyloxypropyl)oxy]-2-hydroxyphenyl]-4,6-bis(2,4-dimethylphenyl)-1,3,5-triazine, and the like.

[0164] The salicylate-based compound may include, for example, phenylsalicylate, 4-*t*-butylphenylsalicylate, and the like.

[0165] A mixing ratio of the first compound to the second compound may be appropriately selected by taking into account device characteristics, the degree of ultraviolet absorption, and/or the like.

[0166] In one embodiment, the encapsulation unit **300** may further include a third compound that is different from the first compound, and the first compound may be dispersed in the third compound. In one embodiment, the first compound may be simply dispersed in the third compound. In another embodiment, the first compound may be cross-linked to the third compound. For example, the first compound may include a group represented by Formula 2-3, and the first compound may be cross-linked to the third compound.

[0167] In one embodiment, the encapsulation unit **300** may further include a metal, a metal halide, a metal nitride, a metal oxide, a metal oxynitride, a silicon nitride, a silicon oxide, and/or a silicon oxynitride.

[0168] For example, the encapsulation unit **300** may include at least one selected from MgF_2 , LiF, AlF_3 , NaF, a silicon oxide, a silicon nitride, a silicon oxynitride, an aluminum oxide, an aluminum nitride, an aluminum oxynitride, a titanium oxide, a titanium nitride, a tantalum oxide, a tantalum nitride, a hafnium oxide, a hafnium nitride, a zirconium oxide, a zirconium nitride, a cerium oxide, a cerium nitride, a tin oxide, a tin nitride, and a magnesium oxide, but embodiments of the present disclosure are not limited thereto.

[0169] In one embodiment, the encapsulation unit **300** may include at least one organic film and at least one inorganic film, and the at least one organic film may include the first compound.

[0170] For example, the at least one organic film may consist of the first compound.

[0171] In one or more embodiments, the at least one organic film may further include, in addition to the first compound, the second compound. The second compound is the same as described above.

[0172] In one or more embodiments, the at least one organic film may further include, in addition to the first compound, the third compound, and the first compound may be dispersed in the third compound. Here, the first compound may be simply dispersed in the third compound, or the first compound may be cross-linked to the third compound.

[0173] For example, the third compound may be a polymer resin. The polymer resin may include, for example, an acryl-based resin, a methacryl-based resin, an isoprene-based resin, a vinyl-based resin, an epoxy-resin resin, a urethane-based resin, a cellulose-based resin, a perylene-based resin, and/or an imide-based resin, but embodiments of the present disclosure are not limited thereto.

[0174] A mixing ratio of the first compound to the third compound may be appropriately selected by taking into account device characteristics, the degree of ultraviolet absorption, and/or the like.

[0175] In one or more embodiments, the at least one organic film may further include the second compound and the third compound in addition to the first compound.

[0176] The at least one organic film may be formed in a certain region utilizing various suitable methods, such as vacuum deposition, spin coating, casting, Langmuir-Blodgett (MB) deposition, ink-jet printing, laser-printing, and laser-induced thermal imaging. The number and thickness of organic films may be appropriately selected by taking into account productivity, device characteristics, and/or the like.

[0177] In one embodiment, the at least one inorganic film may include a metal, a metal halide, a metal nitride, a metal oxide, a metal oxynitride, a silicon nitride, a silicon oxide, and/or a silicon oxynitride.

[0178] For example, the inorganic film may include at least one selected from MgF_2 , LiF, AlF_3 , NaF, a silicon oxide, a silicon nitride, a silicon oxynitride, an aluminum oxide, an aluminum nitride, an aluminum oxynitride, a titanium oxide, a titanium nitride, a tantalum oxide, a tantalum nitride, a hafnium oxide, a hafnium nitride, a zirconium oxide, a zirconium nitride, a cerium oxide, a cerium nitride, a tin oxide, a tin nitride, and a magnesium oxide, but embodiments of the present disclosure are not limited thereto.

[0179] The at least one inorganic film may be formed in a certain region utilizing various suitable methods, such as chemical vapor deposition (CVD), plasma-enhanced chemical vapor deposition (PECVD), sputtering, atomic layer deposition (ALD), and thermal evaporation. The number and thickness of inorganic films may be appropriately selected by taking into account productivity, device characteristics, and/or the like.

[0180] In one embodiment, the at least one organic film may include a first organic film, the at least one inorganic film may include a first inorganic film, and the first organic film may be disposed between the organic light-emitting device **200** and the first inorganic film. For example, the at least one organic film may include a first organic film, the at least one inorganic film may include a first inorganic film, and the first organic film and the second inorganic film may be sequentially stacked from the organic light-emitting device **200** in this stated order. It should be understood that the expression "sequentially stacked" does not exclude a case where another film is disposed between the organic light-emitting device **200** and the first organic film, and/or between the first organic film and the first inorganic film.

[0181] In one or more embodiments, the at least one organic film may include a first organic film, the at least one inorganic film may include a first inorganic film, and the first inorganic film may be disposed between the organic light-emitting device **200** and the first organic film. For example, the at least one organic film may include a first organic film, the at least one inorganic film may include a first inorganic film, and the first organic film and the first inorganic film may be sequentially stacked from the organic light-emitting device **200** in this stated order.

[0182] In one or more embodiments, the at least one organic film may include a first organic film, the at least one inorganic film may include a first inorganic film and a second inorganic film, and the first inorganic film, the first organic film, and the second inorganic film may be sequentially stacked from the organic light-emitting device **200** in this stated order.

[0183] In one or more embodiments, the at least one organic film may include a first organic film and a second organic film, the at least one inorganic film may include a first inorganic film, and the first organic film, the first inorganic film, and the second organic film may be sequentially stacked from the organic light-emitting device **200** in this stated order.

[0184] In one or more embodiments, the at least one organic film may include a first organic film and a second organic film, the at least one inorganic film may include a first inorganic film and a second inorganic film, and the first inorganic film, the first organic film, the second inorganic film, and the second organic film may be sequentially stacked from the organic light-emitting device **200** in this stated order.

[0185] In one or more embodiments, the at least one organic film may include a first organic film and a second organic film, the at least one inorganic film may include a first inorganic film and a second inorganic film, and the first organic film, the first inorganic film, the second organic film, and the second inorganic film may be sequentially stacked from the organic light-emitting device **200** in this stated order.

[0186] In one or more embodiments, the at least one organic film may include a first organic film and a second

organic film, the at least one inorganic film may include a first inorganic film and a second inorganic film, and the first inorganic film, the second inorganic film, the first organic film, and the second organic film may be sequentially stacked from the organic light-emitting device **200** in this stated order.

[0187] In one or more embodiments, the at least one organic film may include a first organic film and a second organic film, the at least one inorganic film may include a first inorganic film and a second inorganic film, and the first organic film, the second organic film, the first inorganic film, and the second inorganic film may be sequentially stacked from the organic light-emitting device **200** in this stated order.

[0188] In one or more embodiments, the at least one organic film may include a first organic film and a second organic film, the at least one inorganic film may include a first inorganic film, a second inorganic film, and a third inorganic film, and the first inorganic film, the first organic film, the second inorganic film, the second organic film, and the third inorganic film may be sequentially stacked from the organic light-emitting device **200** in this stated order.

[0189] In one or more embodiments, the at least one organic film may include a first organic film, a second organic film, and a third organic film, the at least one inorganic film may include a first inorganic film and a second inorganic film, and the first organic film, the first inorganic film, the second organic film, the second inorganic film, and the third organic film, may be sequentially stacked from the organic light-emitting device **200** in this stated order, but embodiments of the present disclosure are not limited thereto. The number of organic films, the number of inorganic films, and the stacking order of the inorganic films and the organic films may be appropriately changed according to design.

[0190] The organic light-emitting display apparatus **10** may include a plurality of organic light-emitting devices **200**. According to an embodiment, an organic light-emitting display apparatus **10** includes: a substrate; an organic emission unit disposed above the substrate and including a plurality of organic light-emitting devices **200**; and an encapsulation unit **300** disposed above the organic emission unit and sealing the organic emission unit, wherein the encapsulation unit **300** includes the first compound represented by Formula 1. The first compound is the same as described above.

[0191] For example, the encapsulation unit **300** may further include the second compound and/or the third compound in addition to the first compound. The second compound and the third compound are the same as described above.

[0192] In one or more embodiments, the encapsulation unit **300** may further include, in addition to the first compound, a metal, a metal halide, a metal nitride, a metal oxide, a metal oxynitride, a silicon nitride, a silicon oxide, and/or a silicon oxynitride.

[0193] In one or more embodiments, the encapsulation unit **300** may include at least one organic film and at least one inorganic film, and the at least one organic film may include the first compound. The at least one organic film and the at least one inorganic film are the same as described above.

[0194] FIG. 2 is a schematic cross-sectional view of an organic light-emitting display apparatus according to an embodiment

[0195] Referring to FIG. 2, a back plane is formed. The back plane may be understood as including a substrate **100**, a plurality of first electrodes **210R**, **210G**, and **210B** above the substrate **100**, and a pixel defining film **180** exposing at least a part of a central portion of each of the plurality of first electrodes **210R**, **210G**, and **210B**. The pixel defining film **180** may have a shape protruding more (e.g., higher) than the plurality of first electrodes **210R**, **210G**, and **210B** (+z direction) with respect to the substrate **100**.

[0196] The plurality of first electrodes **210R**, **210G**, and **210B** may be understood as pixel electrodes. Among the pixel electrodes, the pixel electrode **210B**, the pixel electrode **210R**, and the pixel electrode **210G** may be understood as a first pixel electrode, a second pixel electrode, and a third pixel electrode, respectively. This is because intermediate layers formed on the first to third pixel electrodes may be different from one another. Hereinafter, for convenience, the terms “pixel electrode **210R**”, “pixel electrode **210G**”, and “pixel electrode **210B**” are utilized instead of the first pixel electrode, the second pixel electrode, and the third pixel electrode. The description of the pixel electrodes are substantially the same as the description of the first electrode.

[0197] The pixel defining film **180** has an opening corresponding to each sub-pixel, that is, an opening exposing the central portions of the pixel electrodes **210R**, **210G**, and **210B** or the entire portions of the pixel electrodes **210R**, **210G**, and **210B**, and thus may serve to define pixels. Also, the pixel defining film **180** increases a distance between ends of the pixel electrodes **210R**, **210G**, and **210B** and a second electrode (not illustrated) above the pixel electrodes **210R**, **210G**, and **210B**, thus preventing or reducing occurrence of arc at the ends of the pixel electrodes **210R**, **210G**, and **210B**.

[0198] If necessary, the back plane may further include various elements. For example, as illustrated in FIG. 2, a thin film transistor TFT or a capacitor Cap may be formed on the substrate **100**. The back plane may include other elements, such as a buffer layer **110** for preventing or substantially preventing impurities from penetrating into a semiconductor layer of the thin film transistor TFT, a gate insulating film **130** for insulating the semiconductor layer of the thin film transistor TFT from a gate electrode thereof, an inter-layer insulating layer **150** for insulating a source electrode and a drain electrode of the thin film transistor TFT from the gate electrode thereof, and a planarization film **170** covering the thin film transistor TFT and having a substantially flat upper surface.

[0199] After the back plane is formed, intermediate layers **220R**, **220G**, and **220B** are formed. The intermediate layers **220R**, **220G**, and **220B** may have a multi-layered structure including an emission layer. In this case, unlike that illustrated in FIG. 2, some of the intermediate layers **220R**, **220G**, and **220B** may be a common layer substantially corresponding to the entire surface of the substrate **100**, and others thereof may be pattern layers patterned corresponding to the pixel electrodes **210R**, **210G**, and **210B**.

[0200] After the intermediate layers **220R**, **220G**, and **220B**, a second electrode **230** is formed on the intermediate layers **220R**, **220G**, and **220B**.

[0201] After the second electrode **230** is formed, an encapsulation unit **300** is formed so as to protect the organic

light-emitting devices **200** including the pixel electrodes **210R**, **210G**, and **210B**, the intermediate layers **220R**, **220G**, and **220B**, and the second electrode **230** from impurities such as external oxygen and/or moisture.

[0202] The encapsulation unit **300** may extend to not only the upper surface but also the side surface of the organic light-emitting device **200** and contact a part of the substrate **100**. Therefore, it is possible to effectively prevent or substantially prevent external oxygen and moisture from penetrating into the organic light-emitting device **200**.

[0203] The encapsulation unit **300** may include the first compound represented by Formula 1.

[0204] The term “C₁-C₆₀ alkyl group” as used herein refers to a linear or branched saturated aliphatic hydrocarbon monovalent group having 1 to 60 carbon atoms, and examples thereof include a methyl group, an ethyl group, a propyl group, an isobutyl group, a sec-butyl group, a tert-butyl group, a pentyl group, an iso-amyl group, and a hexyl group. The term “C₁-C₆₀ alkylene group” as used herein refers to a divalent group having the same (e.g., substantially the same) structure as the C₁-C₆₀ alkyl group.

[0205] The term “C₂-C₆₀ alkenyl group” as used herein refers to a hydrocarbon group having at least one carbon-carbon double bond in the middle or at the terminus of the C₂-C₆₀ alkyl group, and examples thereof include an ethenyl group, a propenyl group, and a butenyl group. The term “C₂-C₆₀ alkenylene group” as used herein refers to a divalent group having the same (e.g., substantially the same) structure as the C₂-C₆₀ alkenyl group.

[0206] The term “C₂-C₆₀ alkynyl group” as used herein refers to a hydrocarbon group having at least one carbon-carbon triple bond in the middle or at the terminus of the C₂-C₆₀ alkyl group, and examples thereof include an ethynyl group, and a propynyl group. The term “C₂-C₆₀ alkynylene group” as used herein refers to a divalent group having the same (e.g., substantially the same) structure as the C₂-C₆₀ alkynyl group.

[0207] The term “C₁-C₆₀ alkoxy group” as used herein refers to a monovalent group represented by —OA₁₀₁ (wherein A₁₀₁ is the C₁-C₆₀ alkyl group), and examples thereof include a methoxy group, an ethoxy group, and an isopropoxy group.

[0208] The term “C₃-C₁₀ cycloalkyl group” as used herein refers to a monovalent saturated hydrocarbon monocyclic group having 3 to 10 carbon atoms, and examples thereof include a cyclopropyl group, a cyclobutyl group, a cyclopentyl group, a cyclohexyl group, and a cycloheptyl group. The term “C₃-C₁₀ cycloalkylene group” as used herein refers to a divalent group having the same (e.g., substantially the same) structure as the C₃-C₁₀ cycloalkyl group.

[0209] The term “C₁-C₁₀ heterocycloalkyl group” as used herein refers to a monovalent monocyclic group having at least one heteroatom selected from N, O, Si, P, and S as a ring-forming atom and 1 to 10 carbon atoms, and examples thereof include a 1,2,3,4-oxatriazolidinyl group, a tetrahydrofuran group, and a tetrahydrothiophenyl group. The term “C₁-C₁₀ heterocycloalkylene group” as used herein refers to a divalent group having the same (e.g., substantially the same) structure as the C₁-C₁₀ heterocycloalkyl group.

[0210] The term “C₃-C₁₀ cycloalkenyl group” as used herein refers to a monovalent monocyclic group that has 3 to 10 carbon atoms and at least one carbon-carbon double bond in the ring thereof and no aromaticity, and examples thereof include a cyclopentenyl group, a cyclohexenyl

group, and a cycloheptenyl group. The term “C₃-C₁₀ cycloalkenylene group” as used herein refers to a divalent group having the same (e.g., substantially the same) structure as the C₃-C₁₀ cycloalkenyl group.

[0211] The term “C₁-C₁₀ heterocycloalkenyl group” as used herein refers to a monovalent monocyclic group that has at least one heteroatom selected from N, O, Si, P, and S as a ring-forming atom, 1 to 10 carbon atoms, and at least one carbon-carbon double bond in its ring. Non-limiting examples of the C₁-C₁₀ heterocycloalkenyl group include a 4,5-dihydro-1,2,3,4-oxatriazolyl group, a 2,3-dihydrofuran group, and a 2,3-dihydrothiophenyl group. The term “C₁-C₁₀ heterocycloalkenylene group” as used herein refers to a divalent group having the same (e.g., substantially the same) structure as the C₁-C₁₀ heterocycloalkenyl group.

[0212] The term “C₆-C₆₀ aryl group” as used herein refers to a monovalent group having a carbocyclic aromatic system having 6 to 60 carbon atoms, and the term “C₆-C₆₀ arylenylene group” as used herein refers to a divalent group having a carbocyclic aromatic system having 6 to 60 carbon atoms. Examples of the C₆-C₆₀ aryl group are a phenyl group, a naphthyl group, an anthracenyl group, a phenanthrenyl group, a pyrenyl group, and a chrysenyl group. When the C₆-C₆₀ aryl group and the C₆-C₆₀ arylenylene group each include two or more rings, the rings may be fused to each other.

[0213] The term “C₁-C₆₀ heteroaryl group” as used herein refers to a monovalent group having a carbocyclic aromatic system that has at least one heteroatom selected from N, O, Si, P, and S as a ring-forming atom, in addition to 1 to 1 carbon atoms. The term “C₁-C₆₀ heteroarylene group” as used herein refers to a divalent group having a carbocyclic aromatic system that has at least one heteroatom selected from N, O, Si, P, and S as a ring-forming atom, in addition to 1 to 60 carbon atoms. Examples of the C₁-C₆₀ heteroaryl group are a pyridinyl group, a pyrimidinyl group, a pyrazinyl group, a pyridazinyl group, a triazinyl group, a quinolinyl group, and an isoquinolinyl group. When the C₁-C₆₀ heteroaryl group and the C₁-C₆₀ heteroarylene group each include two or more rings, the rings may be fused to each other.

[0214] The term “C₆-C₆₀ aryloxy group” as used herein refers to a group represented by —OA₁₀₂ (wherein A₁₀₂ is the C₆-C₆₀ aryl group), and the term “C₆-C₆₀ arylthio group” as used herein refers to a group represented by —SA₁₀₃ (wherein A₁₀₃ is the C₆-C₆₀ aryl group).

[0215] The term “monovalent non-aromatic condensed polycyclic group” as used herein refers to a monovalent group (for example, having 8 to 60 carbon atoms) having two or more rings condensed with each other, only carbon atoms as ring-forming atoms, and no aromaticity in its entire molecular structure. An example of the monovalent non-aromatic condensed polycyclic group is a fluorenyl group. The term “divalent non-aromatic condensed polycyclic group” as used herein refers to a divalent group having the same (e.g., substantially the same) structure as the monovalent non-aromatic condensed polycyclic group.

[0216] The term “monovalent non-aromatic condensed heteropolycyclic group” as used herein refers to a monovalent group (for example, having 1 to 60 carbon atoms) having two or more rings condensed to each other, at least one heteroatom selected from N, O, Si, P, and S, other than carbon atoms, as a ring-forming atom, and no aromaticity in its entire molecular structure. An example of the monovalent non-aromatic condensed heteropolycyclic group is a carba-

zoyl group. The term “divalent non-aromatic condensed heteropolycyclic group” as used herein refers to a divalent group having the same (e.g., substantially the same) structure as the monovalent non-aromatic condensed heteropolycyclic group.

[0217] The term “C₅-C₆₀ carbocyclic group” as used herein refers to a monocyclic or polycyclic group having 5 to 60 carbon atoms in which the ring-forming atoms are carbon atoms only. The C₅-C₆₀ carbocyclic group may be an aromatic carbocyclic group or a non-aromatic carbocyclic group. The C₅-C₅₀ carbocyclic group may be a ring (such as benzene), a monovalent group (such as a phenyl group), or a divalent group (such as a phenylene group). In one or more embodiments, depending on the number of substituents connected to the C₅-C₆₀ carbocyclic group, the C₅-C₆₀ carbocyclic group may be a trivalent group or a quadrivalent group.

[0218] The term “C₁-C₆₀ heterocyclic group” as used herein refers to a group having the same (e.g., substantially the same) structure as the C₅-C₆₀ carbocyclic group, except that as a ring-forming atom, at least one heteroatom selected from N, O, Si, P, and S is utilized in addition to carbon (the number of carbon atoms may be in a range of 1 to 60).

[0219] At least one substituent of the substituted C₅-C₆₀ carbocyclic group, the substituted C₁-C₆₀ heterocyclic group, the substituted C₃-C₁₀ cycloalkylene group, the substituted C₁-C₁₀ heterocycloalkylene group, the substituted C₃-C₁₀ cycloalkenylene group, the substituted C₁-C₁₀ heterocycloalkenylene group, the substituted C₆-C₆₀ arylene group, the substituted C₁-C₆₀ heteroarylene group, the substituted divalent non-aromatic condensed polycyclic group, the substituted divalent non-aromatic condensed heteropolycyclic group, the substituted C₁-C₆₀ alkyl group, the substituted C₂-C₆₀ alkenyl group, the substituted C₂-C₆₀ alkynyl group, the substituted C₁-C₆₀ alkoxy group, the substituted C₃-C₆₀ cycloalkoxy group, the substituted C₃-C₁₀ cycloalkyl group, the substituted C₁-C₁₀ heterocycloalkyl group, the substituted C₃-C₁₀ cycloalkenyl group, the substituted C₁-C₁₀ heterocycloalkenyl group, the substituted C₆-C₆₀ aryl group, the substituted C₆-C₆₀ aryloxy group, the substituted C₆-C₆₀ arylthio group, the substituted C₁-C₆₀ heteroaryl group, the substituted monovalent non-aromatic condensed polycyclic group, and the substituted monovalent non-aromatic condensed heteropolycyclic group may be selected from:

[0220] deuterium (-D), -F, -Cl, -Br, -I, a hydroxyl group, a cyano group, a nitro group, an amidino group, a hydrazino group, a hydrazono group, a C₁-C₆₀ alkyl group, a C₂-C₆₀ alkenyl group, a C₂-C₆₀ alkynyl group, a C₁-C₆₀ alkoxy group, and a C₃-C₆₀ cycloalkoxy group;

[0221] a C₁-C₆₀ alkyl group, a C₂-C₆₀ alkenyl group, a C₂-C₆₀ alkynyl group, a C₁-C₆₀ alkoxy group, and a C₃-C₆₀ cycloalkoxy group, each substituted with at least one selected from deuterium, -F, -Cl, -Br, -I, a hydroxyl group, a cyano group, a nitro group, an amidino group, a hydrazino group, a hydrazono group, a C₃-C₁₀ cycloalkyl group, a C₁-C₁₀ heterocycloalkyl group, a C₃-C₁₀ cycloalkenyl group, a C₁-C₁₀ heterocycloalkenyl group, a C₆-C₆₀ aryl group, a C₆-C₆₀ aryloxy group, a C₆-C₆₀ arylthio group, a C₁-C₆₀ heteroaryl group, a monovalent non-aromatic condensed polycyclic group, a monovalent non-aromatic condensed heteropolycyclic group, -Si(Q₁₁)(Q₁₂)(Q₁₃), -N(Q₁₁)(Q₁₂), -B(Q₁₁)(Q₁₂), -C(=O)(Q₁₁), -S(=O)₂(Q₁₁), and -P(=O)(Q₁₁)(Q₁₂);

[0222] a C₃-C₁₀ cycloalkyl group, a C₁-C₁₀ heterocycloalkyl group, a C₃-C₁₀ cycloalkenyl group, a C₁-C₁₀ heterocycloalkenyl group, a C₆-C₆₀ aryl group, a C₆-C₆₀ aryloxy group, a C₆-C₆₀ arylthio group, a C₁-C₆₀ heteroaryl group, a monovalent non-aromatic condensed polycyclic group, and a monovalent non-aromatic condensed heteropolycyclic group;

[0223] a C₃-C₁₀ cycloalkyl group, a C₁-C₁₀ heterocycloalkyl group, a C₃-C₁₀ cycloalkenyl group, a C₁-C₁₀ heterocycloalkenyl group, a C₆-C₆₀ aryl group, a C₆-C₆₀ aryloxy group, a C₆-C₆₀ arylthio group, a C₁-C₆₀ heteroaryl group, a monovalent non-aromatic condensed polycyclic group, and a monovalent non-aromatic condensed heteropolycyclic group, each substituted with at least one selected from deuterium, -F, -Cl, -Br, -I, a hydroxyl group, a cyano group, a nitro group, an amidino group, a hydrazino group, a hydrazono group, a C₁-C₆₀ alkyl group, a C₂-C₆₀ alkenyl group, a C₂-C₆₀ alkynyl group, a C₁-C₆₀ alkoxy group, a C₃-C₆₀ cycloalkoxy group, a C₃-C₁₀ cycloalkyl group, a C₁-C₁₀ heterocycloalkyl group, a C₃-C₁₀ cycloalkenyl group, a C₁-C₁₀ heterocycloalkenyl group, a C₆-C₆₀ aryl group, a C₆-C₆₀ aryloxy group, a C₆-C₆₀ arylthio group, a C₁-C₆₀ heteroaryl group, a monovalent non-aromatic condensed polycyclic group, a monovalent non-aromatic condensed heteropolycyclic group, -Si(Q₂₁)(Q₂₂)(Q₂₃), -N(Q₂₁)(Q₂₂), -B(Q₂₁)(Q₂₂), -C(=O)(Q₂₁), -S(=O)₂(Q₂₁), and -P(=O)(Q₂₁)(Q₂₂); and

[0224] -Si(Q₃₁)(Q₃₂)(Q₃₃), -N(Q₃₁)(Q₃₂), -B(Q₃₁)(Q₃₂), -C(=O)(Q₃₁), -S(=O)₂(Q₃₁), and -P(=O)(Q₃₁)(Q₃₂), and

[0225] Q₁₁ to Q₁₃, Q₂₁ to Q₂₃, and Q₃₁ to Q₃₃ may each independently be selected from hydrogen, deuterium, -F, -Cl, -Br, -I, a hydroxyl group, a cyano group, a nitro group, an amidino group, a hydrazino group, a hydrazono group, a C₁-C₆₀ alkyl group, a C₂-C₆₀ alkenyl group, a C₂-C₆₀ alkynyl group, a C₁-C₆₀ alkoxy group, a C₃-C₆₀ cycloalkoxy group, a C₃-C₁₀ cycloalkyl group, a C₁-C₁₀ heterocycloalkyl group, a C₃-C₁₀ cycloalkenyl group, a C₁-C₁₀ heterocycloalkenyl group, a C₆-C₆₀ aryl group, a C₁-C₆₀ heteroaryl group, a monovalent non-aromatic condensed polycyclic group, a monovalent non-aromatic condensed heteropolycyclic group, a biphenyl group, and a terphenyl group.

[0226] The term “Ph” as used herein represents a phenyl group, the term “Me” as used herein represents a methyl group, the term “Et” as used herein represents an ethyl group, the term “ter-Bu” or “Bu” as used herein represents a tert-butyl group, and the term “OMe” as used herein represents a methoxy group.

[0227] The term “biphenyl group” as used herein refers to a “phenyl group substituted with a phenyl group. The “biphenyl group” is a “substituted phenyl group” having a “C₆-C₆₀ aryl group” as a substituent.

[0228] The term “terphenyl group” as used herein refers to a “phenyl group substituted with a biphenyl group. The “terphenyl group” is a “phenyl group” having, as a substituent, a “C₆-C₆₀ aryl group substituted with a C₆-C₆₀ aryl group.”

[0229] * and * as used herein, unless defined otherwise, each refer to a binding site to a neighboring atom in a corresponding formula.

[0230] Hereinafter, a compound according to embodiments and an organic light-emitting device according to embodiments will be described in more detail with reference

to Synthesis Examples and Examples. The expression “B was utilized instead of A” utilized in describing Synthesis Examples refers to that an identical number of molar equivalents of B was utilized in place of molar equivalents of A.

EXAMPLES

Synthesis Example 1: Synthesis of Compound 5

[0231]

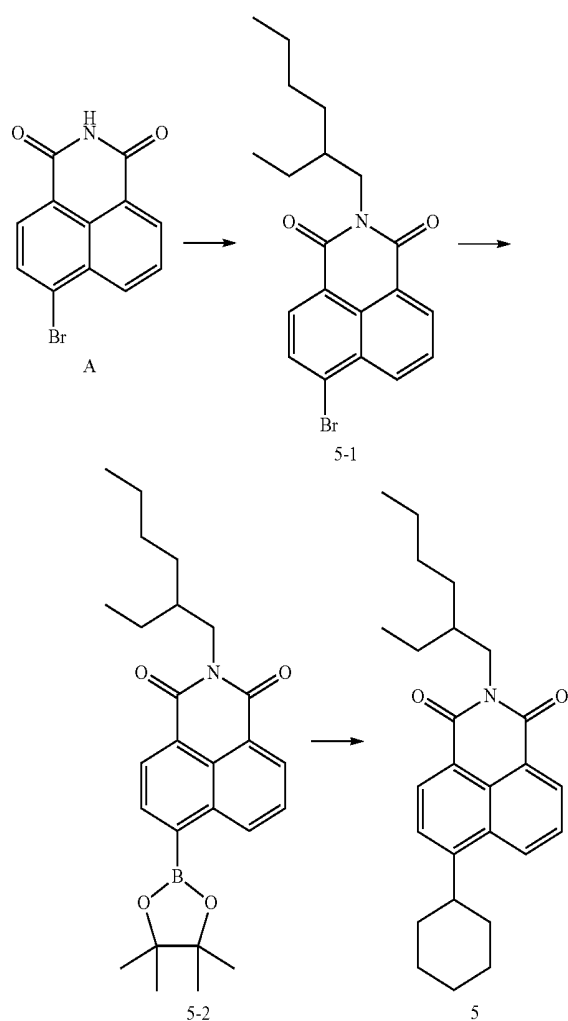

Synthesis of Intermediate 5-1

[0232] 5 g of Intermediate A (6-bromo-1H-benzo[de]isoquinoline-1,3(2H)-dione) was dissolved in dimethylformamide (DMF), and 5 g of K_2CO_3 and 4 g of 3-(bromomethyl)hexane were added thereto. The mixture was stirred at a temperature of 50° C. for 24 hours, and the reaction was terminated by water. An extraction process was performed thereon three times utilizing ethyl acetate, a drying process was performed thereon utilizing anhydrous magnesium sulfate, and a filtering process was performed thereon under reduced pressure. Then, the residue obtained therefrom was separated and purified by column chromatography to obtain 5.6 g (80%) of Intermediate 5-1.

Synthesis of Intermediate 5-2

[0233] 5.6 g of Intermediate 5-1 was diluted in toluene, and 5 g of KOAc, 4.6 g of bis(pinacolato)diboron, and 0.5 g of $Pd(dppf)_2Cl_2$ were added thereto and stirred under reflux. After 17 hours, the mixture was cooled to room temperature, and the reaction was terminated by water. An extraction process was performed thereon three times utilizing ethyl acetate, a drying process was performed thereon utilizing anhydrous magnesium sulfate, and a filtering process was performed thereon under reduced pressure. Then, the residue obtained therefrom was separated and purified by column chromatography to obtain 5.1g (81%) of Intermediate 5-2.

Synthesis of Compound 5

[0234] 5.1 g of Intermediate 5-2, 2.56 g of 1,4-dibromobenzene, 8 g of Cs_2CO_3 , and 0.8 g of $Pd(PPh_3)_4$ were diluted in toluene and stirred under reflux. After 20 hours, the mixture was cooled to room temperature, and the reaction was terminated by water. An extraction process was performed thereon three times utilizing ethyl acetate, a drying process was performed thereon utilizing anhydrous magnesium sulfate, and a filtering process was performed thereon under reduced pressure. Then, the residue obtained therefrom was separated and purified by column chromatography to obtain 3.0 g (70%) of Compound 5.

Synthesis Example 2: Synthesis of Compound 7

[0235]

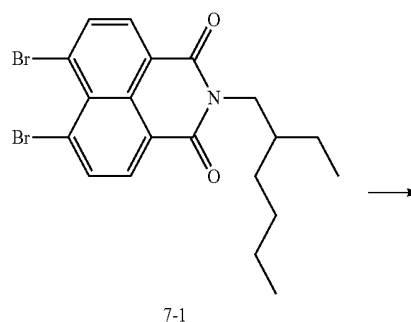
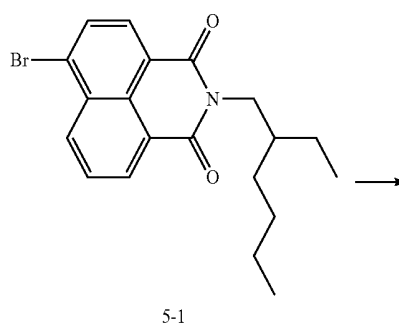

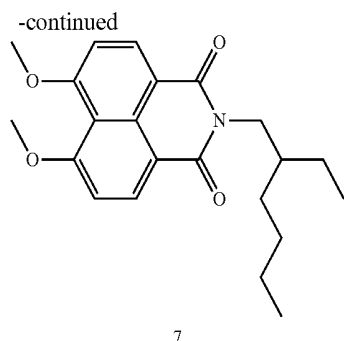

Synthesis of Intermediate 7-1

[0236] 1.8 g of Intermediate 5-1 was diluted in methylene chloride (MC) and 900 mg of NBS was added dropwise thereto. The mixture was stirred for 15 hours, and the reaction was terminated by water. An extraction process was performed thereon three times, a drying process was performed thereon utilizing anhydrous magnesium sulfate, and a filtering process was performed thereon under reduced pressure. Then, the residue obtained therefrom was separated and purified by column chromatography to obtain 2 g (93%) of Intermediate 7-1. The obtained compound was confirmed by LC-MS. $C_{20}H_{21}Br_2NO_2$:M+ 465.2.

Synthesis of Compound 7

[0237] 2 g of Compound 7-1 was diluted in DMSO and 2 g of NaOMe was added dropwise thereto. The reaction vessel was stirred at a temperature of 60° C. and slowly cooled to room temperature after 6 hours. The reaction was terminated by water, and the residue obtained therefrom was filtered under reduced pressure to obtain 1.4 g (88%) of Compound 7.

Synthesis Example 3: Synthesis of Compound 61

[0238]

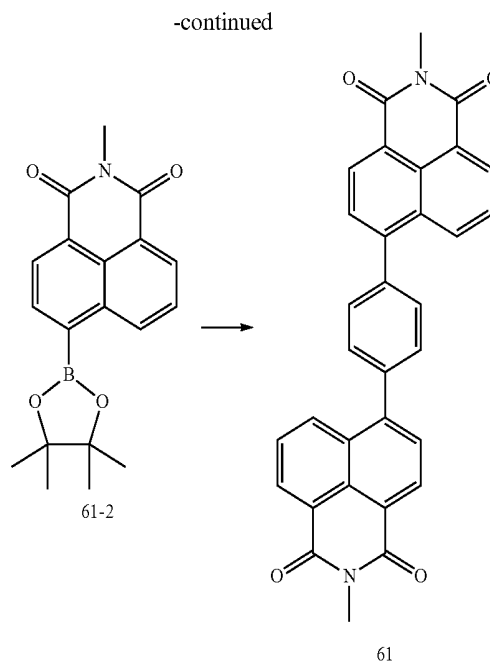
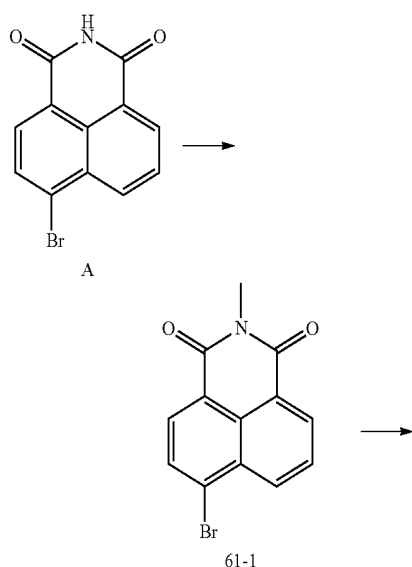

Synthesis of Intermediate 61-1

[0239] 5 g of Intermediate A was dissolved in DMF, and 5 g of K_2CO_3 and 3 g of iodomethane were added thereto. The mixture was stirred at a temperature of 50° C. for 24 hours, and the reaction was terminated by water. An extraction process was performed thereon three times utilizing ethyl acetate, a drying process was performed thereon utilizing anhydrous magnesium sulfate, and a filtering process was performed thereon under reduced pressure. Then, the residue obtained therefrom was separated and purified by column chromatography to obtain 4.6 g (88%) of Intermediate 61-1. The obtained compound was confirmed by LC-MS. $C_{19}H_{15}Br$:M+ 324.2.

Synthesis of Intermediate 61-2

[0240] 4.6 g of Intermediate 61-1 was diluted in toluene, and 5 g of KOAc, 4.6 g of bis(pinacolato)diboron, and 0.5 g of $Pd(dppf)_2Cl_2$ were added thereto and stirred under reflux. After 17 hours, the mixture was cooled to room temperature, and the reaction was terminated by water. An extraction process was performed thereon three times utilizing ethyl acetate, a drying process was performed thereon utilizing anhydrous magnesium sulfate, and a filtering process was performed thereon under reduced pressure. Then, the residue obtained therefrom was separated and purified by column chromatography to obtain 4.3 g (81%) of Intermediate 61-2. The obtained compound was confirmed by LC-MS. $C_{19}H_{15}Br$:M+ 324.2.

Synthesis of Compound 61

[0241] 4.3 g of Intermediate 61-2, 2 g of 1,4-dibromobenzene, 8 g of Cs_2CO_3 , and 0.8 g of $Pd(PPh_3)_4$ were diluted in toluene and stirred under reflux. After 20 hours, the mixture was cooled to room temperature, and the reaction was terminated by water. An extraction process was performed thereon three times utilizing ethyl acetate, a drying process was performed thereon utilizing anhydrous magnesium sul-

fate, and a filtering process was performed thereon under reduced pressure. Then, the residue obtained therefrom was separated and purified by column chromatography to obtain 2.8 g (76%) of Compound 61.

Synthesis Example 4: Synthesis of Compound 67

[0242]

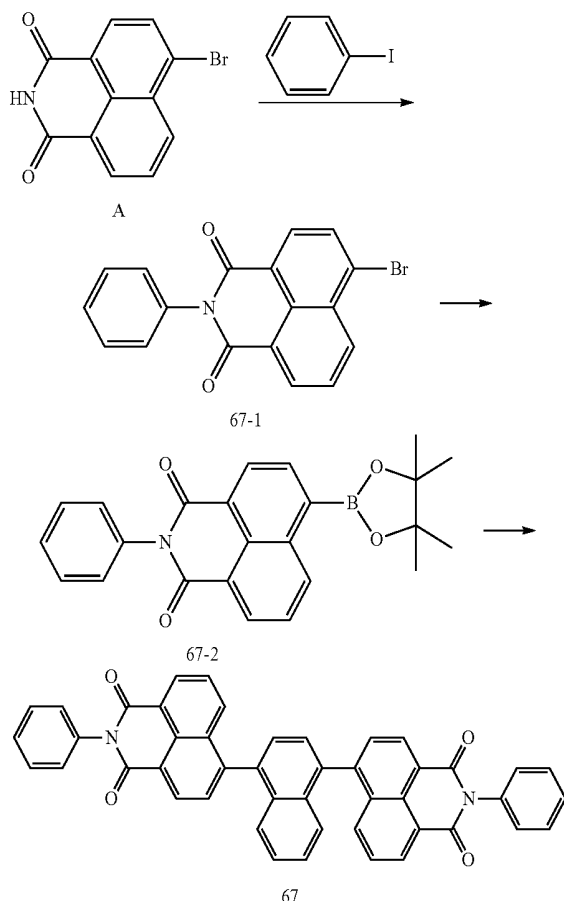

Synthesis of Intermediate 67-1

[0243] 2.8 g of Intermediate A, 2.1 g of iodobenzene, 5.4 g of KOtBu, 0.2 g of P(tBu)₃, and 0.4 g of Pd₂(dba)₃ were diluted in toluene and stirred under reflux. After 20 hours, the mixture was cooled to room temperature, and the reaction was terminated by water. An extraction process was performed thereon three times utilizing ethyl acetate, a drying process was performed thereon utilizing anhydrous magnesium sulfate, and a filtering process was performed thereon under reduced pressure. Then, the residue obtained therefrom was separated and purified by column chromatography to obtain 2.9 g (80%) of Intermediate 67-1. The obtained compound was confirmed by LC-MS. C₁₈H₁₀BrNO₂:M+ 351.0.

Synthesis of Intermediate 67-2

[0244] 2.8 g (84%) of Intermediate 67-2 was synthesized in the same (e.g., substantially the same) manner as in Synthesis of Intermediate 61-2, except that 2.9 g of Inter-

mediate 67-1 was utilized. The obtained compound was confirmed by LC-MS. C₂₄H₂₂BNO₄:M+ 399.2.

Synthesis of Compound 67

[0245] 2.1 g (45%) of Compound 67 was synthesized in the same (e.g., substantially the same) manner as in Synthesis of Compound 61, except that 2.8 g of Intermediate 67-2 and 1 g of 1,4-dibromonaphthalene were utilized.

Synthesis Example 5: Synthesis of Compound 76

[0246]

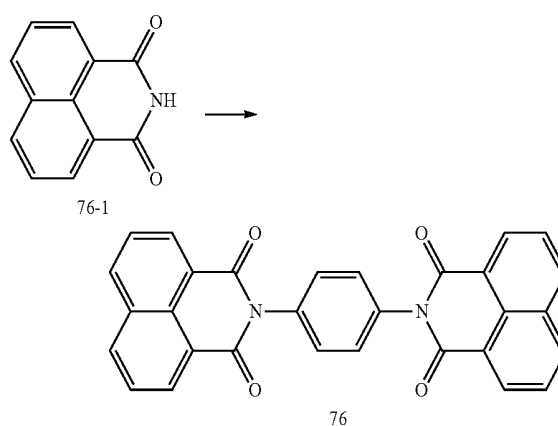

[0247] 2.99 g (63%) of Compound 76 was synthesized in the same (e.g., substantially the same) manner as in Synthesis of Compound 67-1, except that Compound 76-1 and 1,4-dibromonaphthalene were utilized.

Synthesis Example 6: Synthesis of Compound 88

[0248]

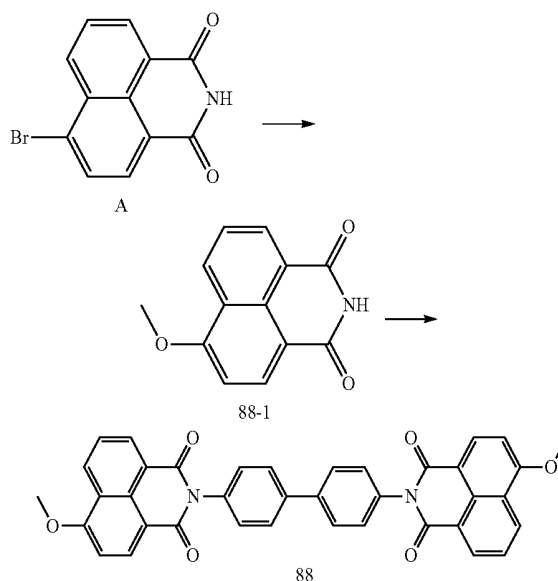

Synthesis of Intermediate 88-1

[0249] 2 g of Compound A was diluted in DMSO and 2 g of NaOMe was added dropwise thereto. The reaction vessel was stirred at a temperature of 60° C. and slowly cooled to room temperature after 6 hours. The reaction was terminated by water, and the residue obtained therefrom was filtered under reduced pressure to obtain 1.3 g (79%) of Intermediate 88-1. The obtained compound was confirmed by LC-MS. $C_{13}H_9NO_3$:M+ 227.1.

Synthesis of Compound 88

[0250] 2 g (58%) of Compound 88 was synthesized in the same (e.g., substantially the same) manner as in Synthesis of Compound 61, except that 1.3 g of Intermediate 88-1 and 0.89 g of 4,4'-dibromo-1,1'-biphenyl were utilized.

Synthesis Example 7: Synthesis of Compound 111

[0251]

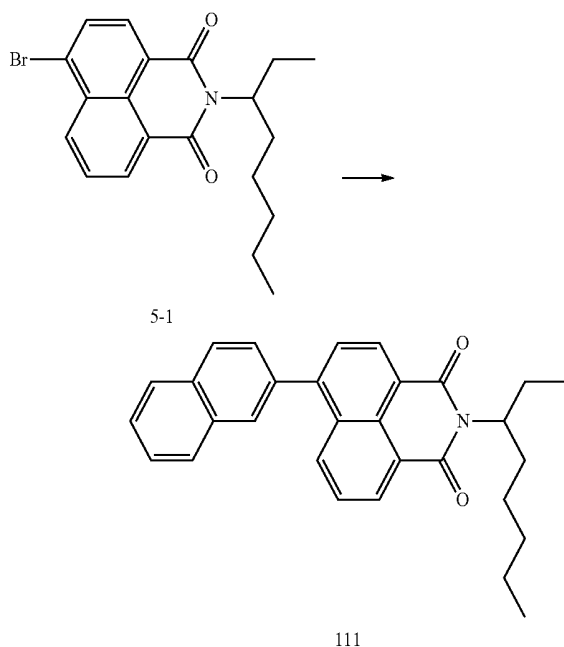

[0252] 1.6 g (80%) of Compound 111 was synthesized in the same (e.g., substantially the same) manner as in Synthesis of Compound 61, except that 1.8 g of Intermediate 5-1 and 1 g of naphthalen-2-yl boronic acid were utilized.

Synthesis Example 8: Synthesis of Compound 120

[0253]

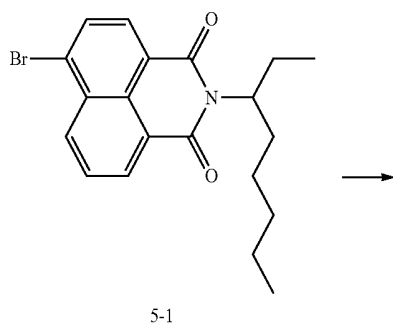

-continued

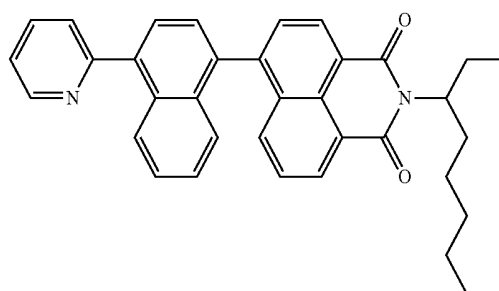

120

[0254] 1.1 g (42%) of Compound 120 was synthesized in the same (e.g., substantially the same) manner as in Synthesis of Compound 61, except that 2 g of Intermediate 5-1 and 1.7 g of (4-(pyridin-2-yl)naphthalen-1-yl)boronic acid were utilized.

Synthesis Example 9: Synthesis of Compound 169

[0255]

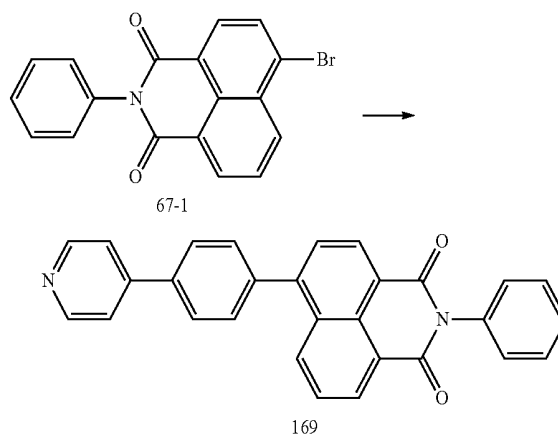

[0256] 1.4 g (49%) of Compound 169 was synthesized in the same (e.g., substantially the same) manner as in Synthesis of Compound 61, except that 2.3 g of Intermediate 67-1 and 1.7 g of (4-(pyridin-4-yl)phenyl)boronic acid were utilized.

Synthesis Example 10: Synthesis of Compound 181

[0257]

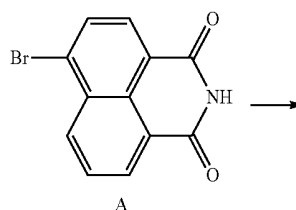

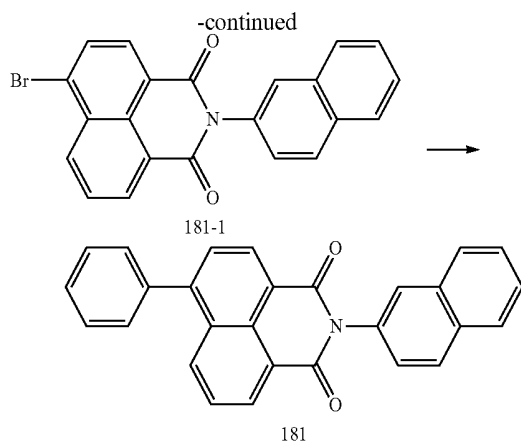

Synthesis of Intermediate 181-1

[0258] 1.6 g (73%) of Intermediate 181-1 was synthesized in the same (e.g., substantially the same) manner as in Synthesis of Intermediate 67-1, except that 1.5 g of Intermediate A and 1.5 g of 2-iodonaphthalene were utilized. The obtained compound was confirmed by LC-MS. $C_{22}H_{12}BrNO_2$:M+ 401.0

Synthesis of Compound 181

[0259] 1.2 g (78%) of Compound 181 was synthesized in the same (e.g., substantially the same) manner as in Synthesis of Compound 61, except that 1.6 g of Intermediate 181-1 and 1.3 g of phenylboronic acid were utilized.

Synthesis Example 11: Synthesis of Compound 198

[0260]

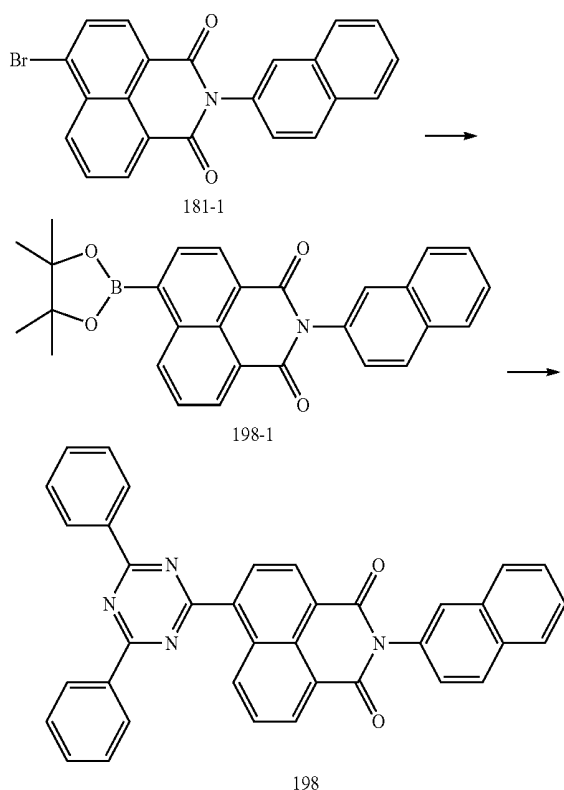

Synthesis of Intermediate 198-1

[0261] 1.9 g (87%) of Intermediate 198-1 was synthesized in the same (e.g., substantially the same) manner as in Synthesis of Intermediate 67-2, except that 2 g of Intermediate 181-1 was utilized. The obtained compound was confirmed by LC-MS. $C_{28}H_{24}BNO_4$:M+ 449.2.

Synthesis of Compound 198

[0262] 1.5 g (62%) of Compound 198 was synthesized in the same (e.g., substantially the same) manner as in Synthesis of Compound 61, except that 1.9 g of Intermediate 198-1 and 1.3 g of 2-chloro-4,6-diphenyl-1,3,5-triazine were utilized.

TABLE 1

Com- pound	¹ H NMR(CDCl ₃ , 400 MHz)	LC-MS	
		found	Calc
5	8.48-8.33(m, 3H), 7.88(m, 1H), 7.11(m, 1H) 3.12(d, 2H), 2.72(m, 1H), 1.92-0.88(m, 25H)	391.2	391.2
7	8.69(d, 2H), 6.95(d, 2H), 4.03(s, 6H), 3.68(m, 2H), 2.11(m, 1H), 1.45-1.20(m, 8H), 0.87(t, 6H)	465.0	465.0
61	8.59(d, 2H), 8.22(d, 2H), 8.12(d, 2H), 7.85(m, 2H), 7.75(m, 4H), 7.70(m, 2H), 3.48(s, 6H)	469.2	496.1
67	8.43-8.40(m, 2H), 8.22(m, 2H), 8.11(dd, 2H), 8.05(br, 2H), 7.71-7.40(m, 16H), 7.00 (m, 2H)	670.7	670.7
76	8.41 (dd, 4H) 8.24 (dd, 4H), 8.74-7.69(m, 8H)	468.6	468.5
88	8.55-8.42(m, 6H) 7.63-7.55(m, 6H), 7.23- 7.18(m, 4H), 6.83(d, 2H), 4.02(s, 6H)	604.6	604.6
111	8.51(d, 1H), 8.18-8.08(m, 2H), 7.99-7.88(m, 3H), 7.69-7.52(m, 4H), 7.32(d, 1H), 5.01 (m, 1H), 2.20(2H), 1.97-1.89(m, 2H), 1.71-1.52(m, 2H), 1.36-1.24(m, 2H), 1.04(m, 2H), 0.93-0.83(m, 6H)	435.2	435.2
120	8.72(d, 1H), 8.47(d, 1H), 8.18-8.08(m, 2H), 7.82-7.67(m, 5H), 7.46-7.44(m, 1H), 7.38(m, 1H), 7.25-7.23(m, 2H), 7.06-7.02(d, 1H), 5.01 (m, 1H), 2.20(2H), 1.97-1.89(m, 2H), 1.71- 1.52(m, 2H), 1.36-1.24(m, 2H), 1.04(m, 2H), 0.93-0.83(m, 6H)	512.7	512.7
169	8.73-8.70(m, 2H), 8.48(dd, 1H), 8.16 (td, 2H), 7.81-7.63(m, 6H), 7.52-7.40(m, 7H)	426.5	426.5
181	8.53(d, 1H), 8.33(m, 1H), 8.24(d, 1H), 8.22- 8.12(m, 4H), 7.88-7.65(m, 5H), 7.53-7.28(m, 6H)	399.4	399.4
198	8.86-8.80(m, 4H), 8.72(d, 1H), 8.52(d, 1H), 8.46(dd, 1H), 8.45-8.40(m, 1H), 8.33(m, 1H), 7.92(m, 1H), 7.86(m, 1H), 7.80(m, 1H), 7.63- 7.58(m, 5H), 7.51-7.46(m, 2H), 7.42-7.36(m, 4H), 7.33-7.30(m, 1H)	554.2	554.2

Evaluation Example 1

[0263] UV transmittance of Compounds prepared according to Synthesis Examples 1 to 11 was measured at a concentration of 10^{-5} M in a toluene solvent (i.e., in toluene) utilizing Shimadzu UV-1800, and results thereof are shown in Table 2.

TABLE 2

	UV absorber	Solubility (in toluene)	Transmittance (@ 405 nm)	Transmittance (@ 430 nm)
Comparative	UV	—	1.8	30.00
Example 1	POL	—	—	—
Example 1	5	10 wt %	3.38	40.18
Example 2	7	11 wt %	7.54	75.15

- C_6-C_{60} aryloxy group, a substituted or unsubstituted C_6-C_{60} arylthio group, a substituted or unsubstituted C_1-C_{60} heteroaryl group, a substituted or unsubstituted monovalent non-aromatic condensed polycyclic group, a substituted or unsubstituted monovalent non-aromatic condensed heteropolycyclic group, $Si(Q_1)(Q_2)(Q_3)$, $-N(Q_1)(Q_2)$, $-B(Q_1)(Q_2)$, $-C(=O)(Q_1)$, $-S(=O)_2(Q_1)$, and $-P(=O)(Q_1)(Q_2)$,
- R_6 to R_9 , R_{11} , and R_{12} are each independently selected from hydrogen, deuterium, $-F$, $-Cl$, $-Br$, $-I$, a hydroxyl group, a cyano group, a nitro group, an amidino group, a hydrazino group, a hydrazono group, a substituted or unsubstituted C_1-C_{60} alkyl group, a substituted or unsubstituted C_2-C_{60} alkenyl group, a substituted or unsubstituted C_2-C_{60} alkynyl group, a substituted or unsubstituted C_1-C_{60} alkoxy group, a substituted or unsubstituted C_3-C_{60} cycloalkoxy group, a substituted or unsubstituted C_3-C_{10} cycloalkyl group, a substituted or unsubstituted C_1-C_{10} heterocycloalkyl group, a substituted or unsubstituted C_3-C_{10} cycloalkenyl group, a substituted or unsubstituted C_1-C_{10} heterocycloalkenyl group, a substituted or unsubstituted C_6-C_{60} aryl group, a substituted or unsubstituted C_6-C_{60} aryloxy group, a substituted or unsubstituted C_6-C_{60} arylthio group, a substituted or unsubstituted C_1-C_{60} heteroaryl group, a substituted or unsubstituted monovalent non-aromatic condensed polycyclic group, a substituted or unsubstituted monovalent non-aromatic condensed heteropolycyclic group, $Si(Q_4)(Q_5)(Q_6)$, $-N(Q_4)(Q_5)$, $-B(Q_4)(Q_5)$, $-C(=O)(Q_4)$, $-S(=O)_2(Q_4)$, and $-P(=O)(Q_4)(Q_5)$,
- b1 is an integer from 1 to 10, wherein, when b1 is two or more, two or more $*(L_1)_{a1}-R_1(s)$ are identical to or different from each other,
- b2 is an integer from 1 to 10, wherein, when b2 is two or more, two or more $*(L_2)_{a2}-R_2(s)$ are identical to or different from each other,
- b4 is an integer from 0 to 5, wherein, when b4 is two or more, two or more $*(L_4)_{a4}-R_4(s)$ are identical to or different from each other,
- b5 is an integer from 0 to 6, wherein, when b5 is two or more, two or more $*(L_5)_{a5}-R_5(s)$ are identical to or different from each other,
- at least one substituent of the substituted C_1-C_{60} alkylene group, the substituted C_2-C_{60} alkenylene group, the substituted C_2-C_{60} alkynylene group, the substituted C_3-C_{10} cycloalkylene group, the substituted C_1-C_{10} heterocycloalkylene group, the substituted C_3-C_{10} cycloalkenylene group, the substituted C_1-C_{10} heterocycloalkenylene group, the substituted C_6-C_{60} arylene group, the substituted C_1-C_{60} heteroarylene group, the substituted divalent non-aromatic condensed polycyclic group, the substituted divalent non-aromatic condensed heteropolycyclic group, the substituted C_1-C_{60} alkyl group, the substituted C_2-C_{60} alkenyl group, the substituted C_2-C_{60} alkynyl group, the substituted C_1-C_{60} alkoxy group, the substituted C_3-C_{60} cycloalkoxy group, the substituted C_3-C_{10} cycloalkyl group, the substituted C_1-C_{10} heterocycloalkyl group, the substituted C_3-C_{10} cycloalkenyl group, the substituted C_1-C_{10} heterocycloalkenyl group, the substituted C_6-C_{60} aryl group, the substituted C_6-C_{60} aryloxy group, the substituted C_6-C_{60} arylthio group, the substituted C_1-C_{60} heteroaryl group, the substituted monovalent non-aromatic condensed polycyclic group, and the substituted monovalent non-aromatic condensed heteropolycyclic group is selected from: deuterium, $-F$, $-Cl$, $-Br$, $-I$, a hydroxyl group, a cyano group, a nitro group, an amidino group, a hydrazino group, a hydrazono group, a C_1-C_{60} alkyl group, a C_2-C_{60} alkenyl group, a C_2-C_{60} alkynyl group, a C_1-C_{60} alkoxy group, and a C_3-C_{60} cycloalkoxy group;
- a C_1-C_{60} alkyl group, a C_2-C_{60} alkenyl group, a C_2-C_{60} alkynyl group, a C_1-C_{60} alkoxy group, and a C_3-C_{60} cycloalkoxy group, each substituted with at least one selected from deuterium, $-F$, $-Cl$, $-Br$, $-I$, a hydroxyl group, a cyano group, a nitro group, an amidino group, a hydrazino group, a hydrazono group, a C_3-C_{10} cycloalkyl group, a C_1-C_{10} heterocycloalkyl group, a C_3-C_{10} cycloalkenyl group, a C_1-C_{10} heterocycloalkenyl group, a C_6-C_{60} aryl group, a C_6-C_{60} aryloxy group, a C_6-C_{60} arylthio group, a C_1-C_{60} heteroaryl group, a monovalent non-aromatic condensed polycyclic group, a monovalent non-aromatic condensed heteropolycyclic group, $-Si(Q_{11})(Q_{12})(Q_{13})$, $-N(Q_{11})(Q_{12})$, $-B(Q_{11})(Q_{12})$, $-C(=O)(Q_{11})$, $-S(=O)_2(Q_{11})$, and $-P(=O)(Q_{11})(Q_{12})$;
- a C_3-C_{10} cycloalkyl group, a C_1-C_{10} heterocycloalkyl group, a C_3-C_{10} cycloalkenyl group, a C_1-C_{10} heterocycloalkenyl group, a C_6-C_{60} aryl group, a C_6-C_{60} aryloxy group, a C_6-C_{60} arylthio group, a C_1-C_{60} heteroaryl group, a monovalent non-aromatic condensed polycyclic group, a monovalent non-aromatic condensed heteropolycyclic group, a biphenyl group, and a terphenyl group;
- a C_3-C_{10} cycloalkyl group, a C_1-C_{10} heterocycloalkyl group, a C_3-C_{10} cycloalkenyl group, a C_1-C_{10} heterocycloalkenyl group, a C_6-C_{60} aryl group, a C_6-C_{60} aryloxy group, a C_6-C_{60} arylthio group, a C_1-C_{60} heteroaryl group, a monovalent non-aromatic condensed polycyclic group, and a monovalent non-aromatic condensed heteropolycyclic group, each substituted with at least one selected from deuterium, $-F$, $-Cl$, $-Br$, $-I$, a hydroxyl group, a cyano group, a nitro group, an amidino group, a hydrazino group, a hydrazono group, a C_1-C_{60} alkyl group, a C_2-C_{60} alkenyl group, a C_2-C_{60} alkynyl group, a C_1-C_{60} alkoxy group, a C_3-C_{60} cycloalkoxy group, a C_3-C_{10} cycloalkyl group, a C_1-C_{10} heterocycloalkyl group, a C_3-C_{10} cycloalkenyl group, a C_1-C_{10} heterocycloalkenyl group, a C_6-C_{60} aryl group, a C_6-C_{60} aryloxy group, a C_6-C_{60} arylthio group, a C_1-C_{60} heteroaryl group, a monovalent non-aromatic condensed polycyclic group, a monovalent non-aromatic condensed heteropolycyclic group, $-Si(Q_{21})(Q_{22})(Q_{23})$, $-N(Q_{21})(Q_{22})$, $-B(Q_{21})(Q_{22})$, $-C(=O)(Q_{21})$, $-S(=O)_2(Q_{21})$, and $-P(=O)(Q_{21})(Q_{22})$; and $-Si(Q_{31})(Q_{32})(Q_{33})$, $-N(Q_{31})(Q_{32})$, $-B(Q_{31})(Q_{32})$, $-C(=O)(Q_{31})$, $-S(=O)_2(Q_{31})$, and $-P(=O)(Q_{31})(Q_{32})$,
- Q_1 to Q_6 , Q_{11} to Q_{13} , Q_{21} to Q_{23} , and Q_{31} to Q_{33} are each independently selected from hydrogen, deuterium, $-F$, $-Cl$, $-Br$, $-I$, a hydroxyl group, a cyano group, a nitro group, an amidino group, a hydrazino group, a hydrazono group, a C_1-C_{60} alkyl group, a C_2-C_{60} alkenyl group, a C_2-C_{60} alkynyl group, a C_1-C_{60} alkoxy group, a C_3-C_{60} cycloalkoxy group, a C_3-C_{10} cycloalkyl group, a C_1-C_{10} heterocycloalkyl group, a C_3-C_{10} cycloalkenyl group, a C_1-C_{10} heterocycloalkenyl group, a C_6-C_{60} aryl group, a C_6-C_{60} aryloxy group, a C_6-C_{60} arylthio group, a C_1-C_{60} heteroaryl group, a monovalent non-aromatic condensed polycyclic group, and a monovalent non-aromatic condensed heteropolycyclic group.

cycloalkyl group, a C₁-C₁₀ heterocycloalkyl group, a C₃-C₁₀ cycloalkenyl group, a C₁-C₁₀ heterocycloalkenyl group, a C₆-C₆₀ aryl group, a C₆-C₆₀ aryl group substituted with a C₁-C₆₀ alkyl group, a C₆-C₆₀ aryl group substituted with a C₆-C₆₀ aryl group, a terphenyl group, a C₁-C₆₀ heteroaryl group, a C₁-C₆₀ heteroaryl group substituted with a C₁-C₆₀ alkyl group, a C₁-C₆₀ heteroaryl group substituted with a C₆-C₆₀ aryl group, a monovalent non-aromatic condensed polycyclic group, a monovalent non-aromatic condensed heteropolycyclic group, a biphenyl group, and a terphenyl group, and

* and *' each indicate a binding site to a neighboring atom.

2. The organic light-emitting display apparatus of claim 1, wherein

Ar₁ is selected from a benzene group, a naphthalene group, an anthracene group, a phenanthrene group, a pyrene group, a chrysene group, a triphenylene group, an indene group, a fluorene group, a benzofluorene group, a spiro-bifluorene group, a carbazole group, a dibenzofuran group, a dibenzothiophene group, a pyridine group, a pyrazine group, a pyrimidine group, a pyridazine group, a pyrrole group, an imidazole group, a quinoline group, an isoquinoline group, a quinoxaline group, a quinazoline group, a triazine group, an indeno pyrazine group, an indeno pyridine group, a phenanthroline group, and a phenanthridine group.

3. The organic light-emitting display apparatus of claim 1, wherein

L₁ to L₅ and L₉ are each independently selected from:

—S—', *—O—*', *—C(=O)—*', *—S(=O)—*', *—S(=O)₂—*', a C₁-C₂₀ alkylene group, a C₂-C₂₀ alkenylene group, a C₂-C₂₀ alkynylene group, a phenylene group, a pentalenylene group, an indenylene group, a naphthylene group, an azulenylylene group, an indacenylene group, an acenaphthylene group, a fluorenylene group, a spiro-bifluorenylene group, a spiro-benzofluorene-fluorenylene group, a benzofluorenylene group, a dibenzofluorenylene group, a phenalenylene group, a phenanthrenylene group, an anthracenylene group, a fluoranthenylene group, a triphenylenylene group, a pyrenylene group, a chrysenylene group, a perylenylene group, a pentaphenylylene group, a pyrrolylene group, a thiophenylylene group, a furanylylene group, a silolylylene group, an imidazolylene group, a pyrazolylylene group, a thiazolylylene group, an isothiazolylylene group, an oxazolylene group, an isoxazolylene group, a pyridinylylene group, a pyridazinylylene group, an indolylylene group, an isoindolylylene group, an indazolylene group, a purinylylene group, a quinolinylene group, an isoquinolinylene group, a benzoquinolinylene group, a phthalazinylylene group, a naphthyridinylylene group, a quinoxalinylylene group, a quinazolinylene group, a cinnolinylene group, a phenanthridinylylene group, a phenanthrolinylylene group, a phenazinylene group, a benzimidazolylene group, a benzofuranylylene group, a benzothiophenylylene group, a benzosilolylylene group, an isobenzothiazolylylene group, a benzoxazolylene group, an isobenzoxazolylene group, a triazolylene group, a tetrazolylylene group, an oxadiazolylylene group, a triazinylylene group, a dibenzofuranylylene group, a dibenzo-

thiophenylylene group, a dibenzosilolylylene group, a carbazolylylene group, a benzocarbazolylylene group, a dibenzocarbazolylylene group, a thiadiazolylylene group, an imidazopyridinylylene group, an imidazopyrimidinylene group, an oxazolopyridinylylene group, a thiazolopyridinylylene group, a benzonaphthyridinylylene group, an azafluorenylylene group, an azaspiro-bifluorenylylene group, an azacarbazolylylene group, an azadibenzofuranylylene group, an azadibenzothiophenylylene group, and an azadibenzosilolylylene group; and

a C₁-C₂₀ alkylene group, a C₂-C₂₀ alkenylene group, a C₂-C₂₀ alkynylene group, a phenylene group, a pentalenylene group, an indenylene group, a naphthylene group, an azulenylylene group, an indacenylene group, an acenaphthylene group, a fluorenylylene group, a spiro-bifluorenylylene group, a spiro-benzofluorene-fluorenylylene group, a benzofluorenylylene group, a dibenzofluorenylylene group, a phenalenylene group, a phenanthrenylene group, an anthracenylene group, a fluoranthenylene group, a triphenylenylene group, a pyrenylene group, a chrysenylene group, a perylenylene group, a pentaphenylylene group, a pyrrolylylene group, a thiophenylylene group, a furanylylene group, a silolylylene group, an imidazolylene group, a pyrazolylylene group, a thiazolylylene group, an isothiazolylylene group, an oxazolylene group, an isoxazolylene group, a pyridinylylene group, a pyridazinylylene group, an indolylylene group, an isoindolylylene group, an indazolylene group, a purinylylene group, a quinolinylene group, an isoquinolinylene group, a benzoquinolinylene group, a phthalazinylylene group, a naphthyridinylylene group, a quinoxalinylylene group, a quinazolinylene group, a cinnolinylene group, a phenanthridinylylene group, an acridinylylene group, a phenanthrolinylylene group, a phenazinylene group, a benzimidazolylene group, a benzofuranylylene group, a benzothiophenylylene group, a benzosilolylylene group, an isobenzothiazolylylene group, a benzoxazolylene group, an isobenzoxazolylene group, a triazolylene group, a tetrazolylylene group, an oxadiazolylylene group, a triazinylylene group, a dibenzofuranylylene group, a dibenzothiophenylylene group, a dibenzosilolylylene group, a carbazolylylene group, a benzocarbazolylylene group, a dibenzocarbazolylylene group, a thiadiazolylylene group, an imidazopyridinylylene group, an imidazopyrimidinylene group, an oxazolopyridinylylene group, a thiazolopyridinylylene group, a benzonaphthyridinylylene group, an azafluorenylylene group, an azaspiro-bifluorenylylene group, an azacarbazolylylene group, an azadibenzofuranylylene group, an azadibenzothiophenylylene group, and an azadibenzosilolylylene group, each substituted with at least one selected from deuterium, —F, —Cl, —Br, —I, a hydroxyl group, a cyano group, a nitro group, an amidino group, a hydrazino group, a hydrazono group, a C₁-C₂₀ alkyl group, a C₁-C₂₀ alkoxy group, a C₃-C₂₀ cycloalkoxy group, a C₃-C₁₀ cycloalkyl group, a C₁-C₁₀ heterocycloalkyl group, a C₃-C₁₀ cycloalkenyl group, a C₁-C₁₀ heterocycloalkenyl group, a C₆-C₆₀ aryl group, a C₁-C₆₀ heteroaryl group, a monovalent non-aromatic condensed polycyclic group, a monovalent non-aromatic condensed heteropolycyclic group, a biphenyl group, a terphenyl group, and —Si(Q₃₁)(Q₃₂)(Q₃₃).

Q₃₁ to Q₃₃ are each independently selected from:

a C₁-C₁₀ alkyl group, a C₁-C₁₀ alkoxy group, a C₃-C₁₀ cycloalkoxy group, a phenyl group, a biphenyl group, a terphenyl group, a naphthyl group, a pyridinyl group, a pyrimidinyl group, a pyrazinyl group, a quinolinyl group, an isoquinolinyl group, a quinoxalinyl group, and a quinazolinyl group; and

a C₁-C₁₀ alkyl group, a C₁-C₁₀ alkoxy group, a C₃-C₁₀ cycloalkoxy group, a phenyl group, a biphenyl group, a terphenyl group, a naphthyl group, a pyridinyl group, a pyrimidinyl group, a pyrazinyl group, a quinolinyl group, an isoquinolinyl group, a quinoxalinyl group, and a quinazolinyl group, each substituted with at least one selected from a C₁-C₁₀ alkyl group, a C₁-C₁₀ alkoxy group, a C₃-C₁₀ cycloalkoxy group, a phenyl group, a biphenyl group, a terphenyl group, a naphthyl group, a pyridinyl group, a pyrimidinyl group, a pyrazinyl group, a quinolinyl group, an isoquinolinyl group, a quinoxalinyl group, and a quinazolinyl group, and

* and *' each indicate a binding site to a neighboring atom.

4. The organic light-emitting display apparatus of claim 1, wherein

L₁ to L₅ and L₉ are each independently selected from *—S—*', *—O—*', *—C(=O)—*', *—S(=O)—*', *—S(=O)₂—*', *—[C(Z₁)(Z₂)]_n—*', and groups represented by Formulae 3-1 to 3-75:

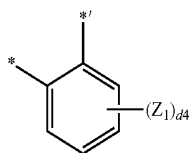

Formula 3-1

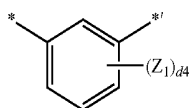

Formula 3-2

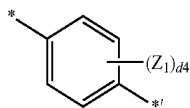

Formula 3-3

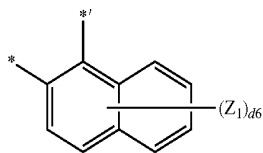

Formula 3-4

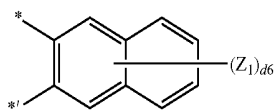

Formula 3-5

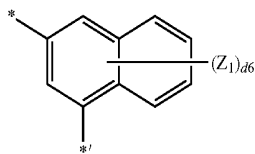

Formula 3-6

-continued

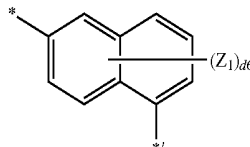

Formula 3-7

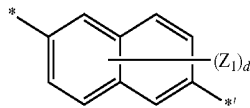

Formula 3-8

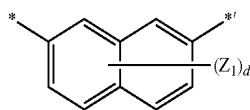

Formula 3-9

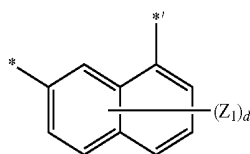

Formula 3-10

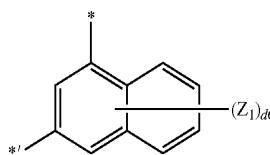

Formula 3-11

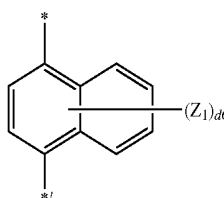

Formula 3-12

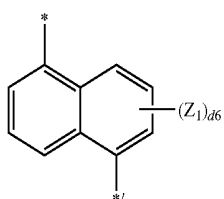

Formula 3-13

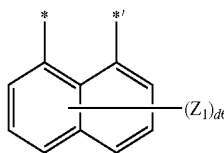

Formula 3-14

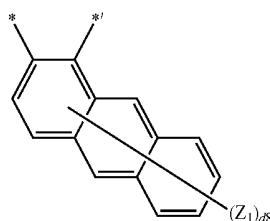

Formula 3-15

-continued

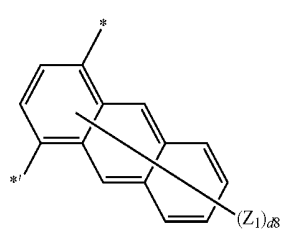
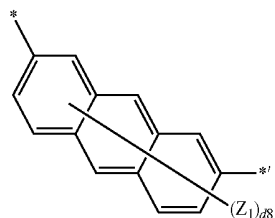
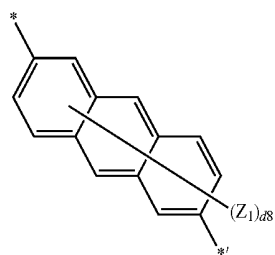
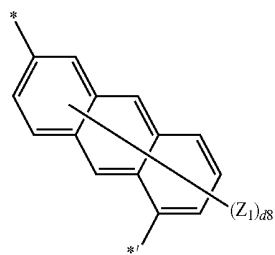
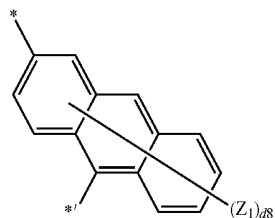
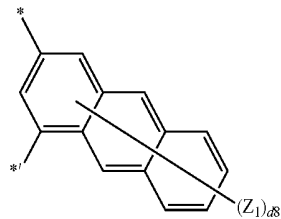
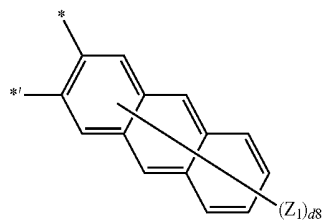

Formula 3-16

Formula 3-17

Formula 3-18

Formula 3-19

Formula 3-20

Formula 3-21

Formula 3-22

-continued

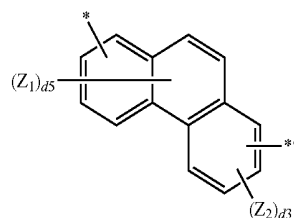
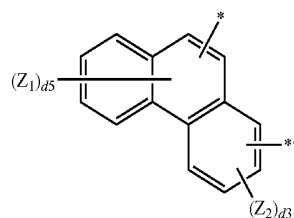
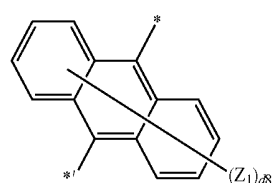
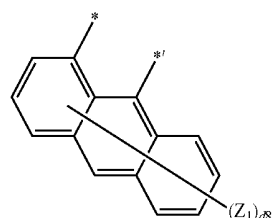
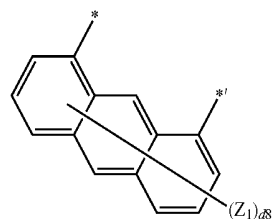
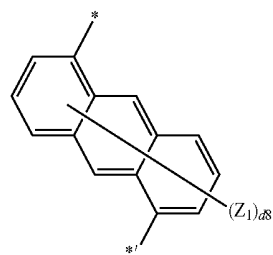
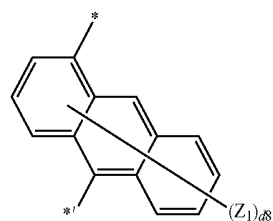

Formula 3-23

Formula 3-24

Formula 3-25

Formula 3-26

Formula 3-27

Formula 3-28

Formula 3-29

-continued

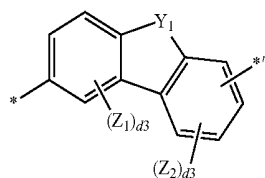
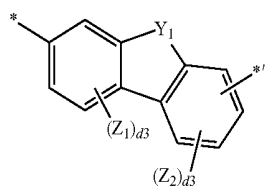
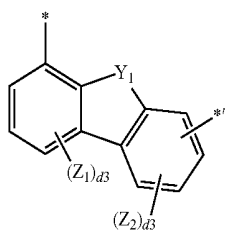
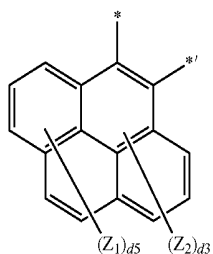
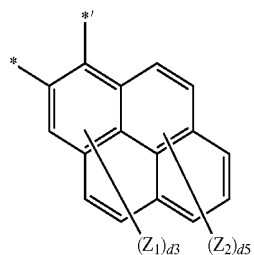
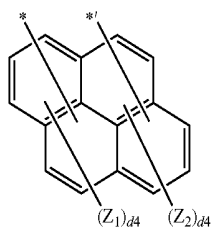
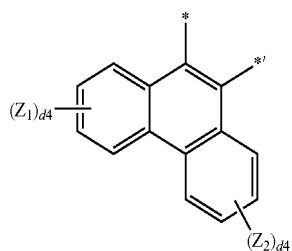

-continued

Formula 3-30

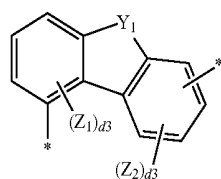

Formula 3-37

Formula 3-31

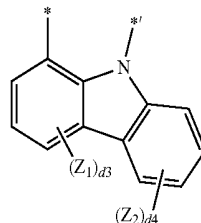

Formula 3-38

Formula 3-32

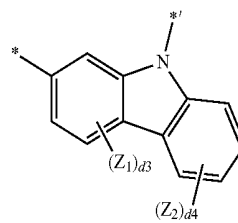

Formula 3-39

Formula 3-33

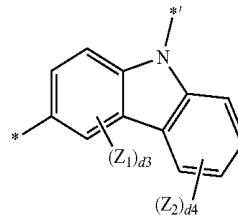

Formula 3-40

Formula 3-34

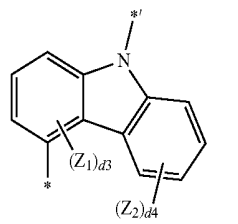

Formula 3-41

Formula 3-35

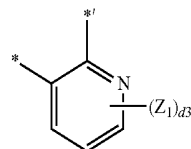

Formula 3-42

Formula 3-36

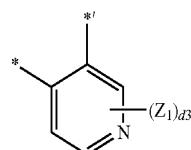

Formula 3-43

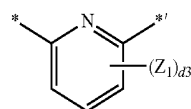

Formula 3-44

-continued

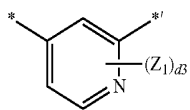

Formula 3-45

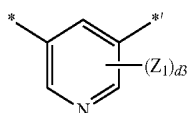

Formula 3-46

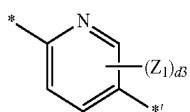

Formula 3-47

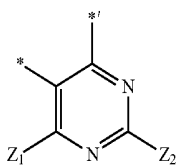

Formula 3-48

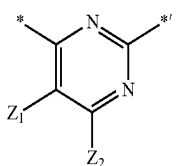

Formula 3-49

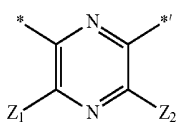

Formula 3-50

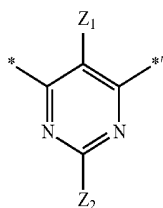

Formula 3-51

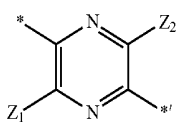

Formula 3-52

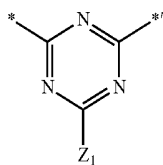

Formula 3-53

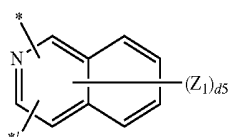

Formula 3-54

-continued

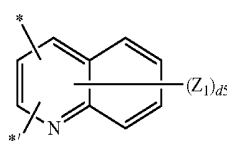

Formula 3-55

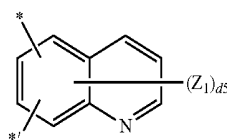

Formula 3-56

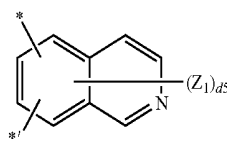

Formula 3-57

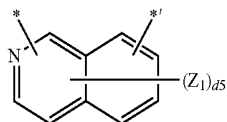

Formula 3-58

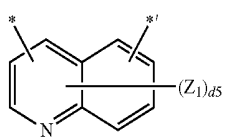

Formula 3-59

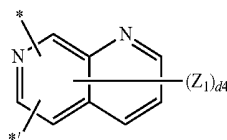

Formula 3-60

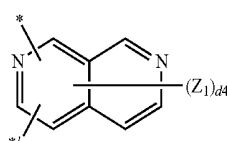

Formula 3-61

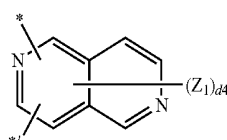

Formula 3-62

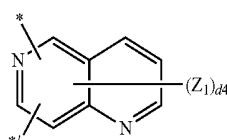

Formula 3-63

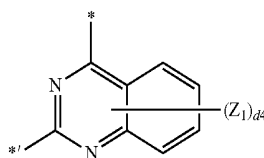

Formula 3-64

-continued

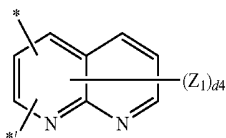

Formula 3-65

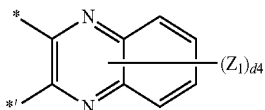

Formula 3-66

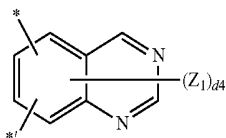

Formula 3-67

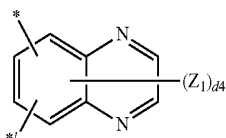

Formula 3-68

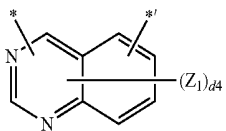

Formula 3-69

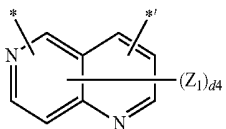

Formula 3-70

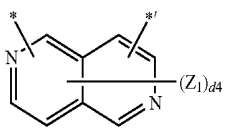

Formula 3-71

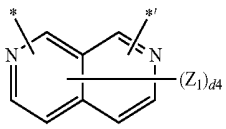

Formula 3-72

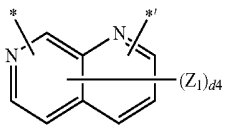

Formula 3-73

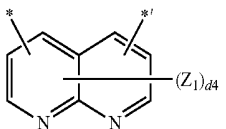

Formula 3-74

-continued

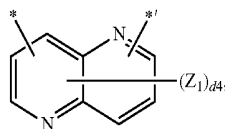

Formula 3-75

wherein, in Formulae 3-1 to 3-75,

Y_1 is O, S, $C(Z_3)(Z_4)$, $N(Z_3)$, or $Si(Z_3)(Z_4)$,

Z_1 to Z_4 are each independently selected from hydrogen, deuterium, $-F$, $-CF_3$, $-Cl$, $-Br$, a hydroxyl group, a cyano group, a nitro group, an amidino group, a hydrazino group, a hydrazono group, a C_1 - C_{20} alkyl group, a C_1 - C_{20} alkoxy group, a C_3 - C_{20} cycloalkoxy group, a phenyl group, a biphenyl group, a terphenyl group, a naphthyl group, a fluorenyl group, a spiro-bifluorenyl group, a benzofluorenyl group, a dibenzofluorenyl group, a phenanthrenyl group, an anthracenyl group, a triphenylenyl group, a pyrenyl group, a chrysenyl group, a pyridinyl group, a pyrazinyl group, a pyrimidinyl group, a pyridazinyl group, a triazinyl group, and $-Si(Q_{31})(Q_{32})(Q_{33})$,

Q_{31} to Q_{33} are each independently selected from a C_1 - C_{10} alkyl group, a C_1 - C_{10} alkoxy group, a C_3 - C_{20} cycloalkoxy group, a phenyl group, a biphenyl group, a terphenyl group, and a naphthyl group,

d_3 is an integer from 1 to 3,

d_4 is an integer from 1 to 4,

d_5 is an integer from 1 to 5,

d_6 is an integer from 1 to 6,

d_8 is an integer from 1 to 8,

n_1 is an integer from 1 to 20, and

* and *' each indicate a binding site to a neighboring atom.

5. The organic light-emitting display apparatus of claim 1, wherein

Ar_1 is selected from groups represented by Formulae 4-1 to 4-59, and

L_1 to L_5 and L_9 are each independently selected from $*-O-*'$, $*-C(=O)-*'$, $*-CH_2-*'$, $*(CH_2)_2-*'$, $*(CH_2)_3-*'$, $*(CH_2)_4-*'$, $*(CH_2)_5-*'$, and groups represented by Formulae 4-1 to 4-58 and 4-60:

Formula 4-1

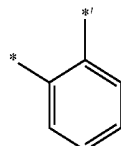

Formula 4-2

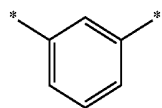

Formula 4-3

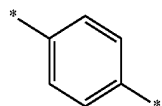

-continued

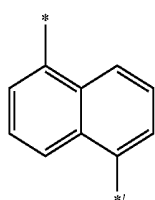
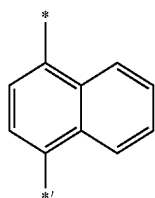
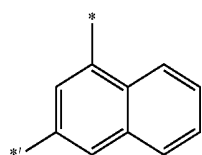
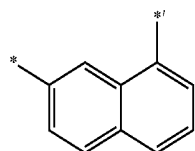
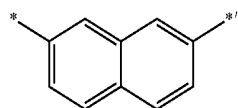
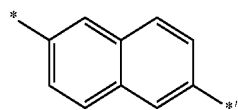
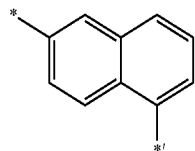
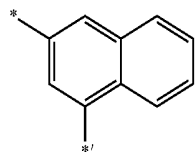
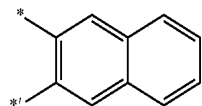
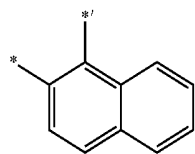

Formula 4-4

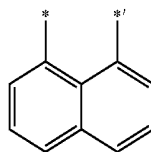

Formula 4-5

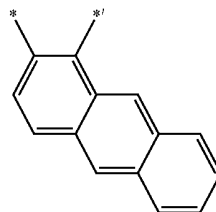

Formula 4-6

Formula 4-7

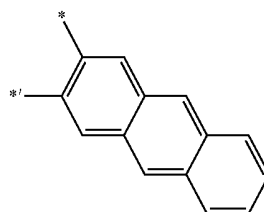

Formula 4-8

Formula 4-9

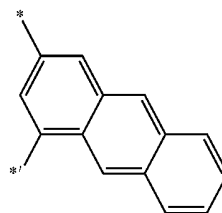

Formula 4-10

Formula 4-11

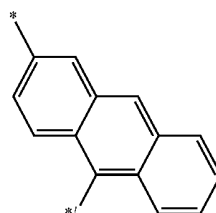

Formula 4-12

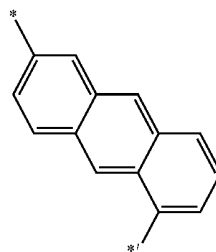

Formula 4-13

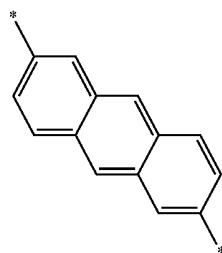

-continued

Formula 4-14

Formula 4-15

Formula 4-16

Formula 4-17

Formula 4-18

Formula 4-19

Formula 4-20

-continued

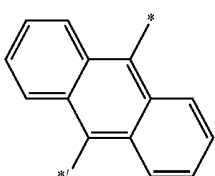
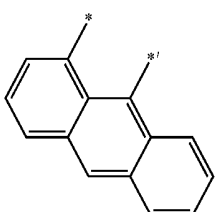
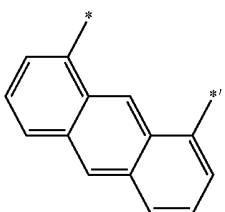
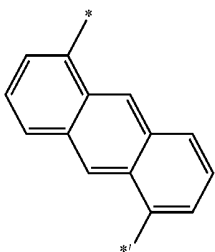
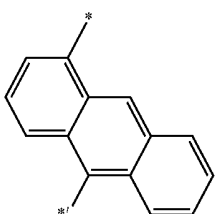
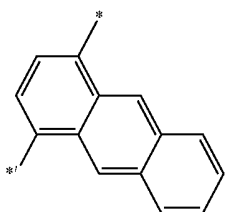
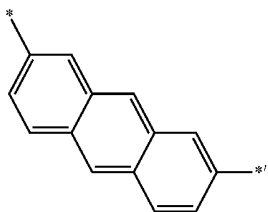

-continued

Formula 4-21

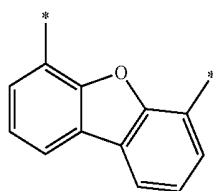

Formula 4-28

Formula 4-22

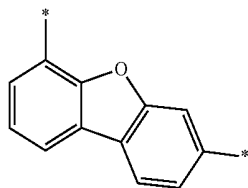

Formula 4-29

Formula 4-23

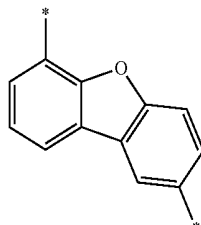

Formula 4-30

Formula 4-24

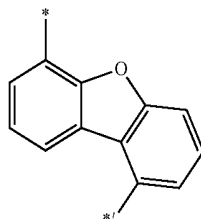

Formula 4-31

Formula 4-25

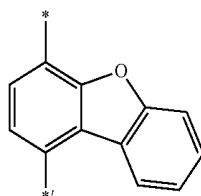

Formula 4-32

Formula 4-26

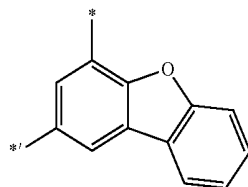

Formula 4-33

Formula 4-27

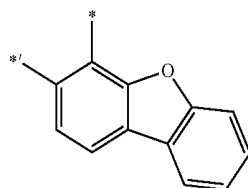

Formula 4-34

Formula 4-35

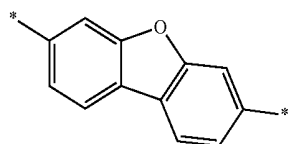

-continued

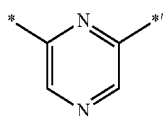

Formula 4-55

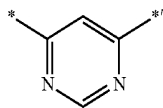

Formula 4-56

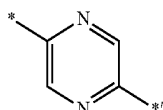

Formula 4-57

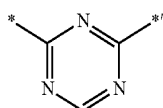

Formula 4-58

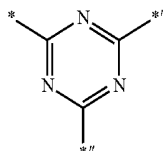

Formula 4-59

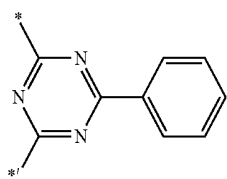

Formula 4-60

wherein *, **, and *** in Formulae 4-1 to 4-60 each indicate a binding site to a neighboring atom.

6. The organic light-emitting display apparatus of claim 1, wherein

the group represented by Formula 2-1 is represented by Formula 2-1A: Formula 2-1A

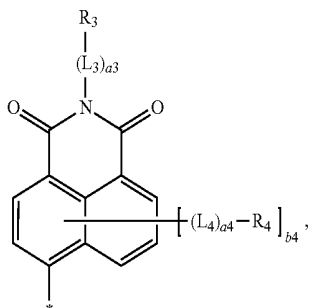

wherein, in Formula 2-1A, L_3 , L_4 , a_3 , a_4 , R_3 , R_4 , and b_4 are the same as described in claim 1, and * indicates a binding site to a neighboring atom.

7. The organic light-emitting display apparatus of claim 1, wherein

R_2 to R_5 are each independently selected from:

a group represented by Formula 2-3, a group represented by Formula 2-4, hydrogen, deuterium, —F, —Cl, —Br, —I, a hydroxyl group, a cyano group, a nitro group, an

amidino group, a hydrazino group, a hydrazono group, a C_1 - C_{20} alkyl group, a C_3 - C_{10} cycloalkyl group, a C_1 - C_{20} alkoxy group, a C_3 - C_{20} cycloalkoxy group, a phenyl group, a biphenyl group, a terphenyl group, a naphthyl group, a fluorenyl group, a spiro-bifluorenyl group, a benzofluorenyl group, a dibenzofluorenyl group, a phenanthrenyl group, an anthracenyl group, a triphenylenyl group, a pyrenyl group, a chrysenyl group, a carbazolyl group, a benzocarbazolyl group, a dibenzocarbazolyl group, a furanyl group, a benzofuranyl group, a dibenzofuranyl group, a thiophenyl group, a benzothiophenyl group, a dibenzothiophenyl group, a pyridinyl group, a pyrazinyl group, a pyrimidinyl group, a pyridazinyl group, a triazinyl group, and —Si(Q_1)(Q_2)(Q_3); and

a C_1 - C_{20} alkyl group, a C_3 - C_{10} cycloalkyl group, a C_1 - C_{20} alkoxy group, a C_3 - C_{20} cycloalkoxy group, a phenyl group, a biphenyl group, a terphenyl group, a naphthyl group, a fluorenyl group, a spiro-bifluorenyl group, a benzofluorenyl group, a dibenzofluorenyl group, a phenanthrenyl group, an anthracenyl group, a triphenylenyl group, a pyrenyl group, a chrysenyl group, a carbazolyl group, a benzocarbazolyl group, a dibenzocarbazolyl group, a furanyl group, a benzofuranyl group, a dibenzofuranyl group, a thiophenyl group, a benzothiophenyl group, a dibenzothiophenyl group, a pyridinyl group, a pyrazinyl group, a pyrimidinyl group, a pyridazinyl group, and a triazinyl group, each substituted with at least one selected from deuterium, —F, —Cl, —Br, —I, a hydroxyl group, a cyano group, a nitro group, an amidino group, a hydrazino group, a hydrazono group, a C_1 - C_{20} alkyl group, a C_3 - C_{10} cycloalkyl group, a C_1 - C_{20} alkoxy group, a C_3 - C_{20} cycloalkoxy group, a phenyl group, a biphenyl group, a terphenyl group, a naphthyl group, a fluorenyl group, a spiro-bifluorenyl group, a benzofluorenyl group, a dibenzofluorenyl group, a phenanthrenyl group, an anthracenyl group, a triphenylenyl group, a pyrenyl group, a chrysenyl group, a carbazolyl group, a benzocarbazolyl group, a dibenzocarbazolyl group, a furanyl group, a benzofuranyl group, a dibenzofuranyl group, a thiophenyl group, a benzothiophenyl group, a dibenzothiophenyl group, a pyridinyl group, a pyrazinyl group, a pyrimidinyl group, a pyridazinyl group, and a triazinyl group, and —Si(Q_{31})(Q_{32})(Q_{33}), and

Q_1 to Q_3 and Q_{31} to Q_{33} are each independently selected from a C_1 - C_{10} alkyl group, a C_1 - C_{10} alkoxy group, a phenyl group, a biphenyl group, a terphenyl group, and a naphthyl group.

8. The organic light-emitting display apparatus of claim 1, wherein

R_6 to R_9 , R_{11} , and R_{12} are each independently selected from:

hydrogen, deuterium, —F, —Cl, —Br, —I, a hydroxyl group, a cyano group, a nitro group, an amidino group, a hydrazino group, a hydrazono group, a C_1 - C_{20} alkyl group, a C_3 - C_{10} cycloalkyl group, a C_1 - C_{20} alkoxy group, a C_3 - C_{20} cycloalkoxy group, a phenyl group, a biphenyl group, a terphenyl group, a naphthyl group, a fluorenyl group, a spiro-bifluorenyl group, a benzofluorenyl group, a dibenzofluorenyl group, a phenanthrenyl group, an anthracenyl group, a triphenylenyl group, a pyrenyl group, a chrysenyl group, a carbazolyl group, a benzocarbazolyl group, a dibenzocarbazolyl group, a

furanyl group, a benzofuranyl group, a dibenzofuranyl group, a thiophenyl group, a benzothiophenyl group, a dibenzothiophenyl group, a pyridinyl group, a pyrazinyl group, a pyrimidinyl group, a pyridazinyl group, a triazinyl group, and $-\text{Si}(\text{Q}_4)(\text{Q}_5)(\text{Q}_6)$; and

a C_1 - C_{20} alkyl group, a C_3 - C_{10} cycloalkyl group, a C_1 - C_{20} alkoxy group, a C_3 - C_{20} cycloalkoxy group, a phenyl group, a biphenyl group, a terphenyl group, a naphthyl group, a fluorenyl group, a spiro-bifluorenyl group, a benzofluorenyl group, a dibenzofluorenyl group, a phenanthrenyl group, an anthracenyl group, a triphenylenyl group, a pyrenyl group, a chrysenyl group, a carbazolyl group, a benzocarbazolyl group, a dibenzocarbazolyl group, a furanyl group, a benzofuranyl group, a dibenzofuranyl group, a thiophenyl group, a benzothiophenyl group, a dibenzothiophenyl group, a pyridinyl group, a pyrazinyl group, a pyrimidinyl group, a pyridazinyl group, and a triazinyl group, each substituted with at least one selected from deuterium, $-\text{F}$, $-\text{Cl}$, $-\text{Br}$, $-\text{I}$, a hydroxyl group, a cyano group, a nitro group, an amidino group, a hydrazino group, a hydrazono group, a C_1 - C_{20} alkyl group, a C_3 - C_{10} cycloalkyl group, a C_1 - C_{20} alkoxy group, a C_3 - C_{20} cycloalkoxy group, a phenyl group, a biphenyl group, a terphenyl group, a naphthyl group, a fluorenyl group, a spiro-bifluorenyl group, a benzofluorenyl group, a dibenzofluorenyl group, a phenanthrenyl group, an anthracenyl group, a triphenylenyl group, a pyrenyl group, a chrysenyl group, a carbazolyl group, a benzocarbazolyl group, a dibenzocarbazolyl group, a furanyl group, a benzofuranyl group, a dibenzofuranyl group, a thiophenyl group, a benzothiophenyl group, a dibenzothiophenyl group, a pyridinyl group, a pyrazinyl group, a pyrimidinyl group, a pyridazinyl group, a triazinyl group, and $-\text{Si}(\text{Q}_{31})(\text{Q}_{32})(\text{Q}_{33})$, and

Q_4 to Q_6 and Q_{31} to Q_{33} are each independently selected from a C_1 - C_{10} alkyl group, a C_1 - C_{10} alkoxy group, a phenyl group, a biphenyl group, a terphenyl group, and a naphthyl group.

9. The organic light-emitting display apparatus of claim 1, wherein

the first compound is represented by one of Formulae 1A to 1P:

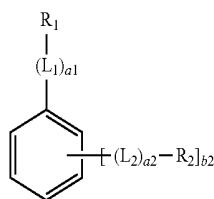

Formula 1A

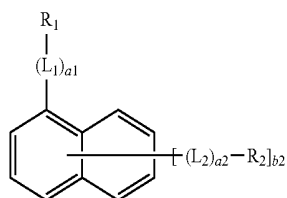

Formula 1B

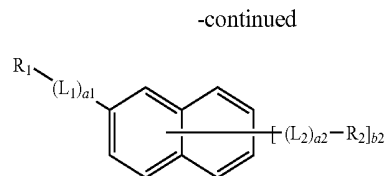

Formula 1C

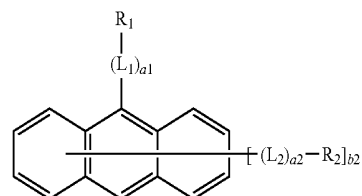

Formula 1D

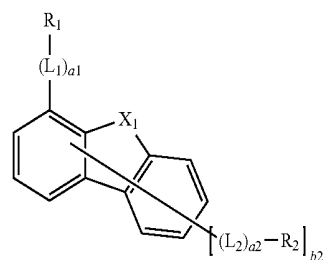

Formula 1E

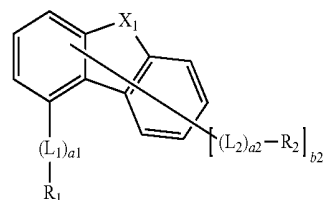

Formula 1F

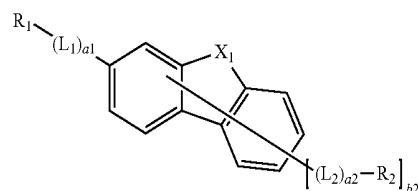

Formula 1G

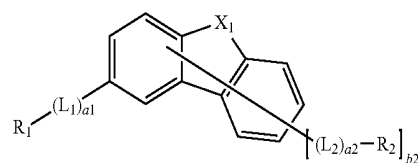

Formula 1H

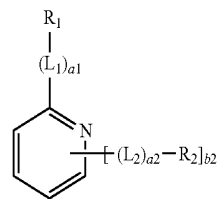

Formula 1I

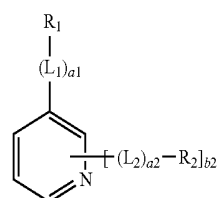

Formula 1J

-continued

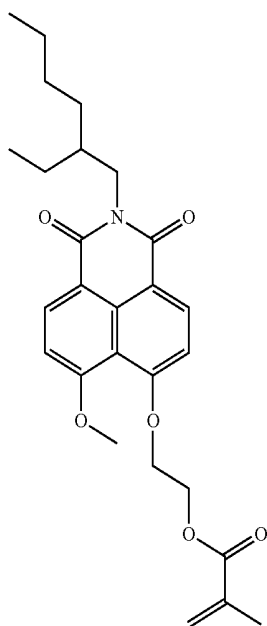

4

-continued

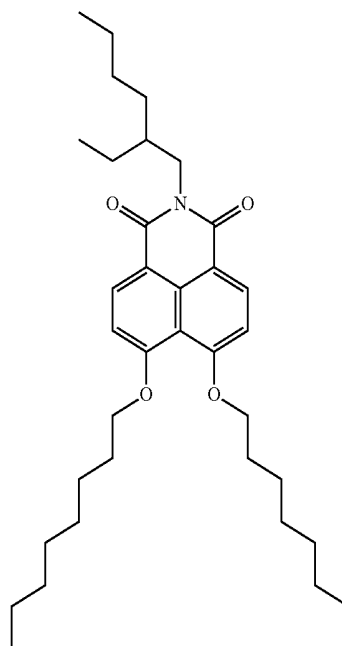

6

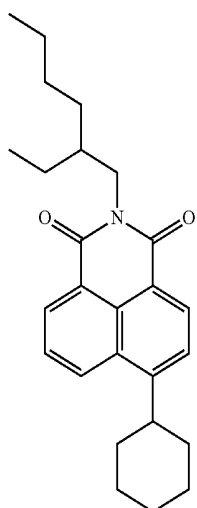

5

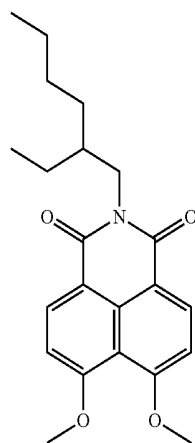

7

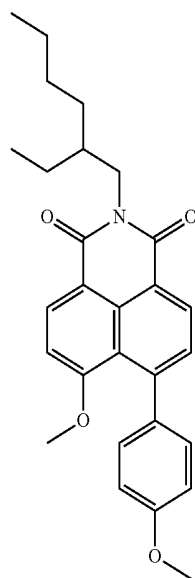

8

-continued

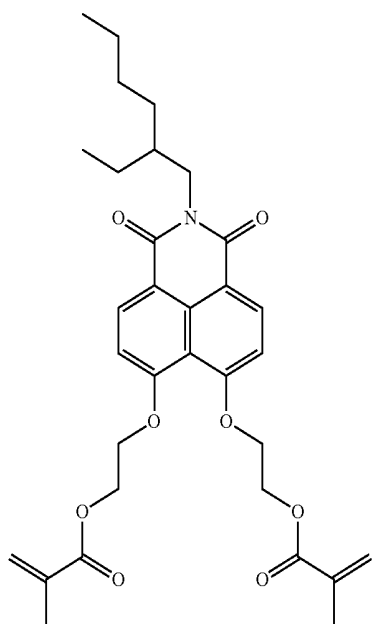

9

-continued

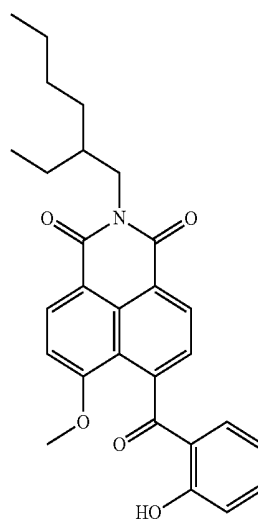

12

10

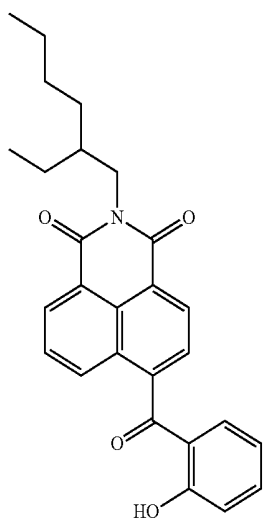

13

11

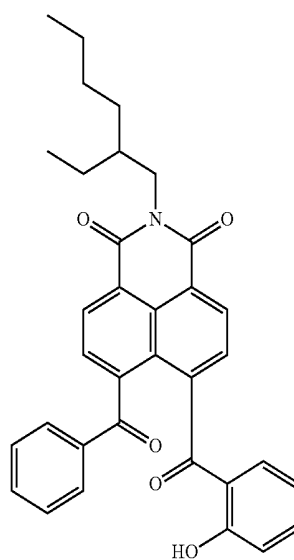

-continued

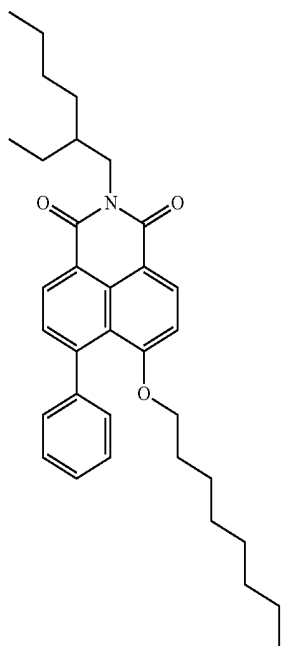

14

-continued

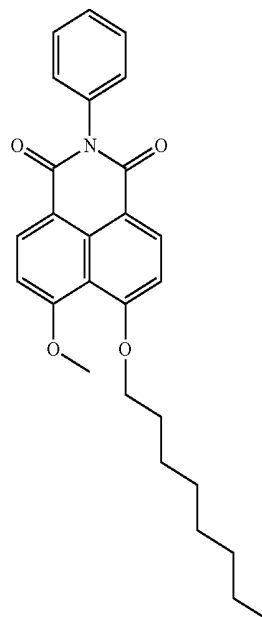

16

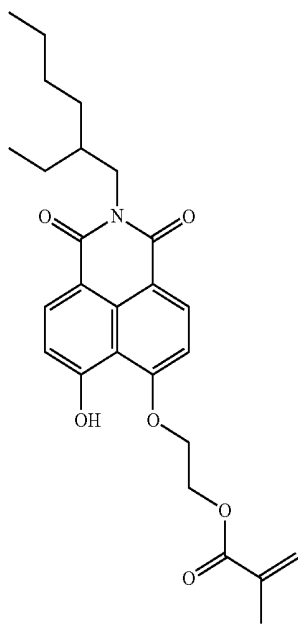

15

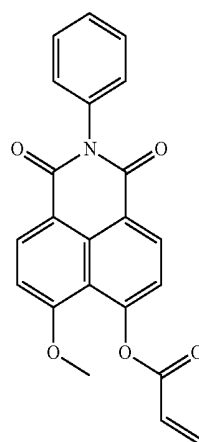

17

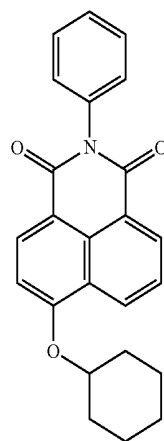

18

-continued

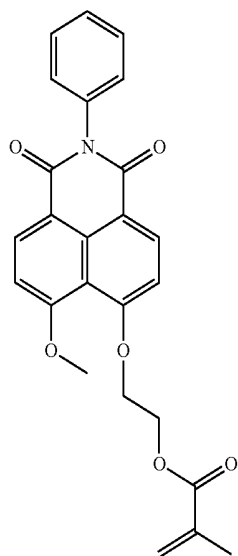

19

-continued

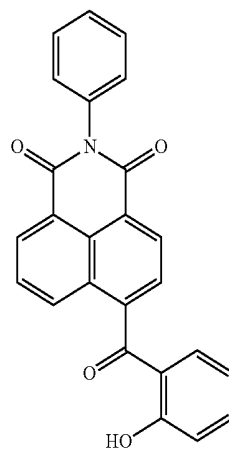

22

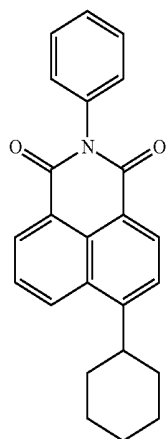

20

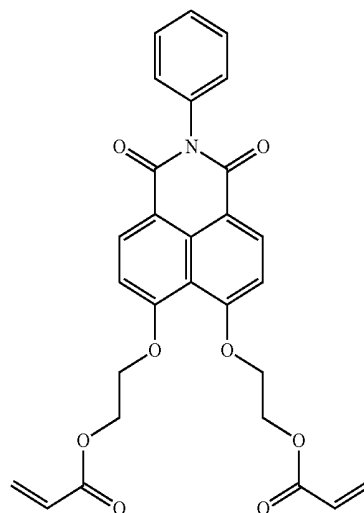

23

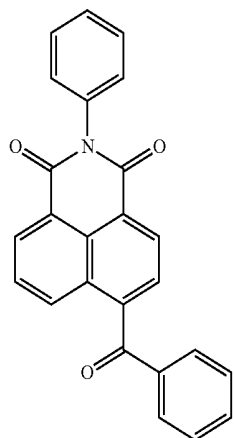

21

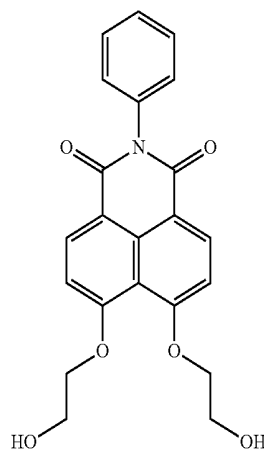

24

-continued

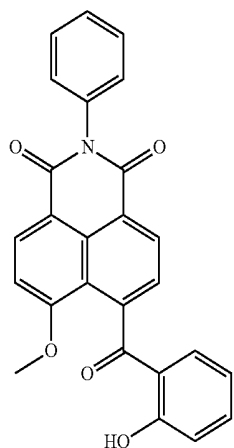

25

-continued

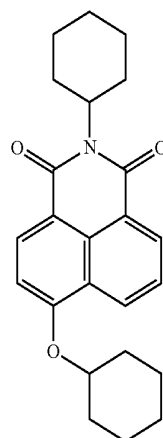

28

26

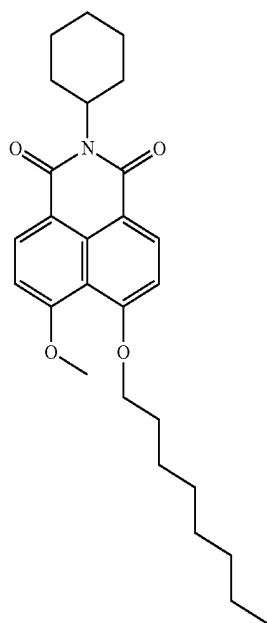

28

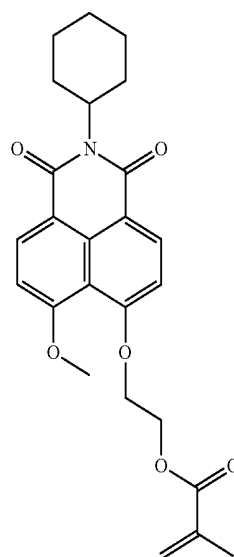

27

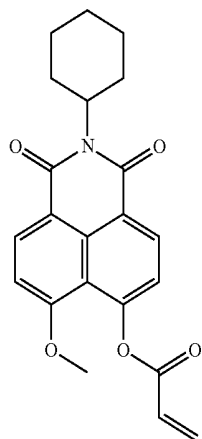

29

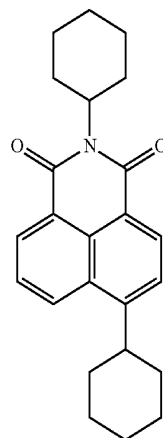

-continued

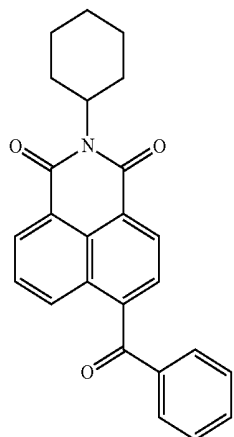

30

-continued

34

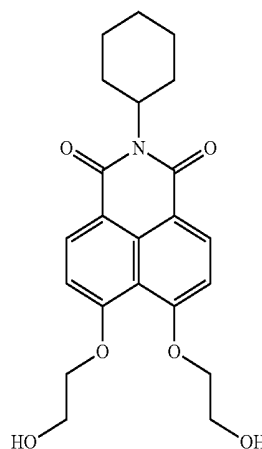

31

35

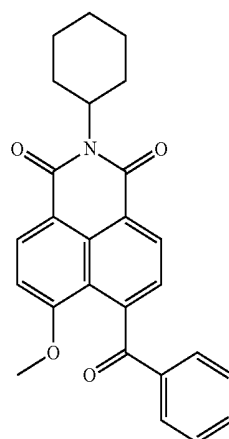
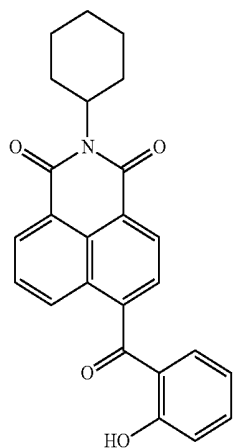

33

36

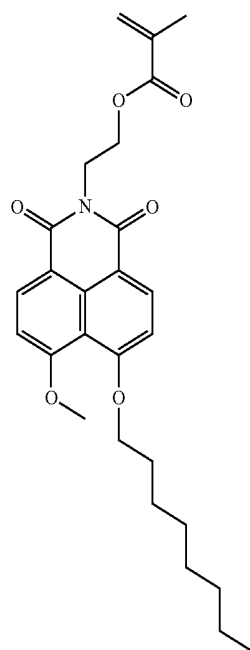
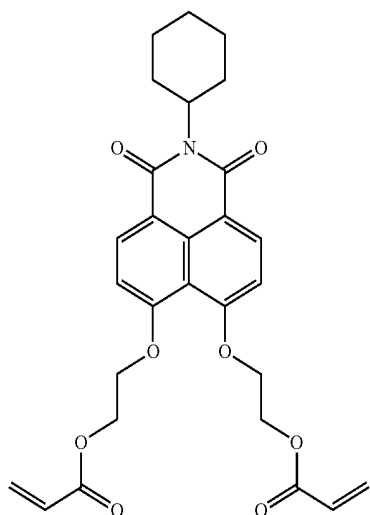

-continued

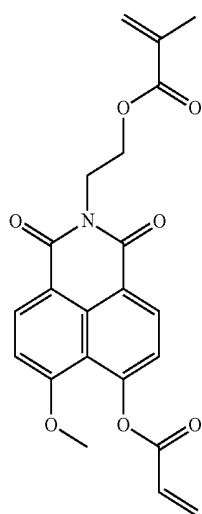

37

-continued

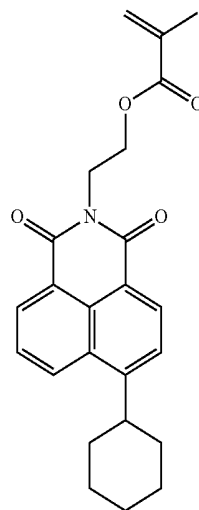

40

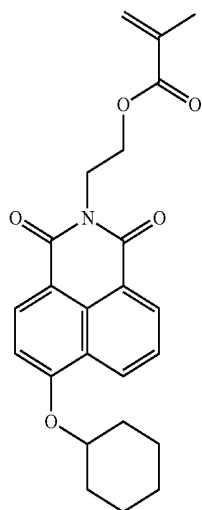

38

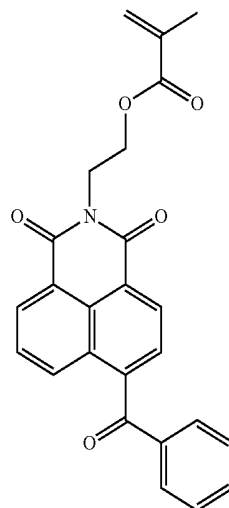

41

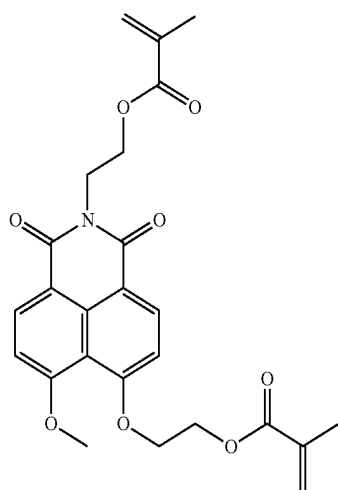

39

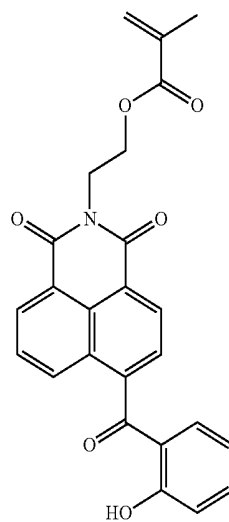

42

-continued

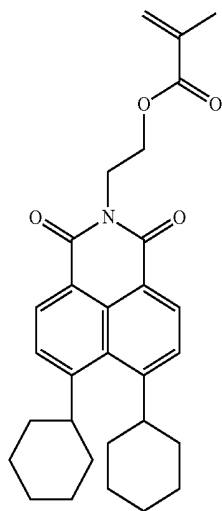

43

-continued

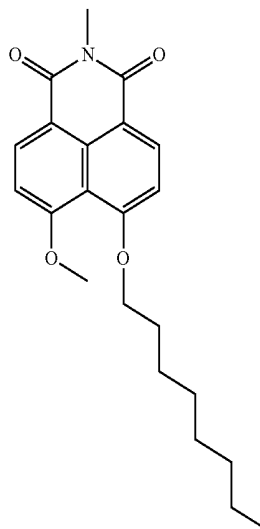

46

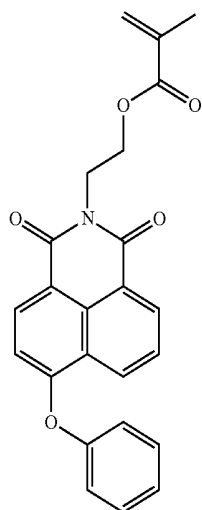

44

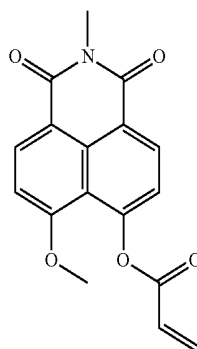

47

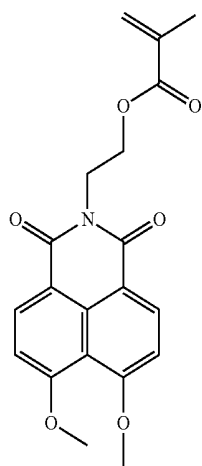

45

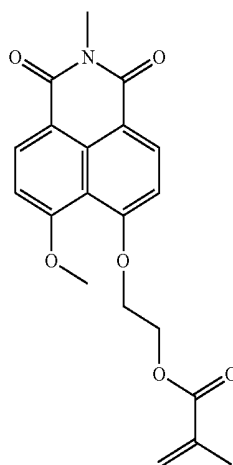

48

-continued

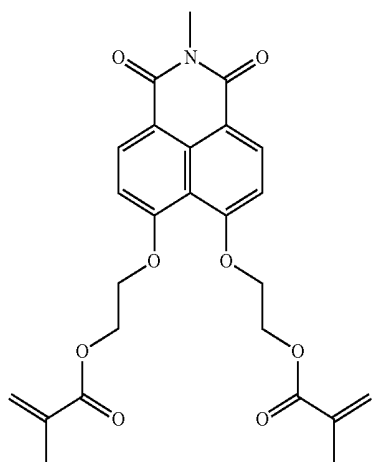

49

-continued

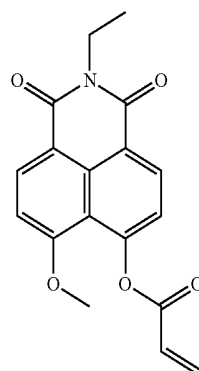

52

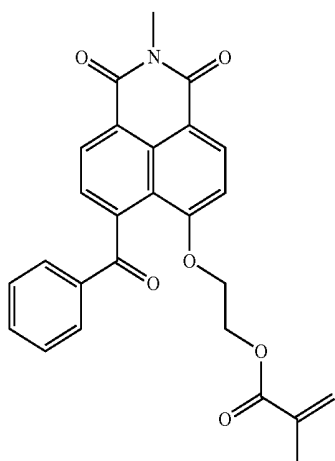

50

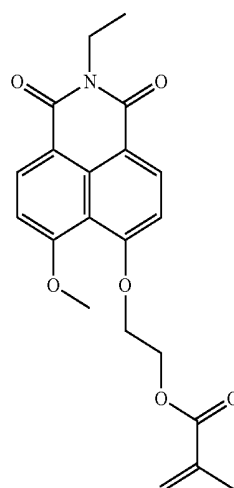

53

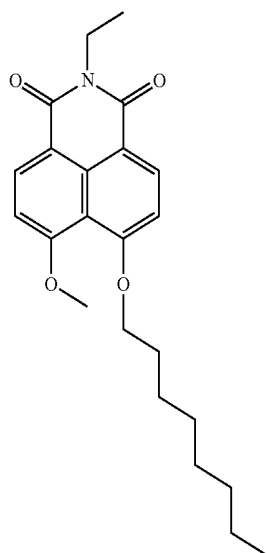

51

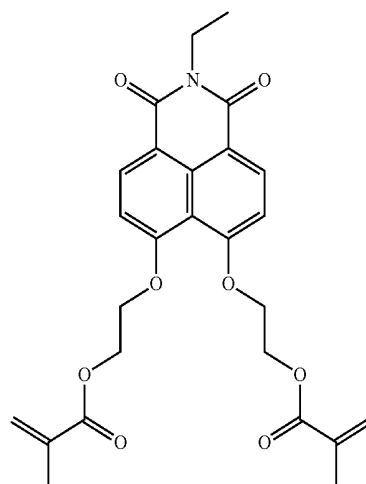

54

-continued

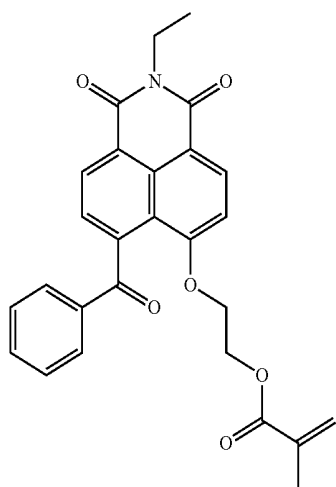

55

-continued

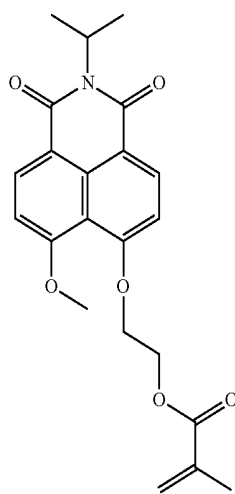

58

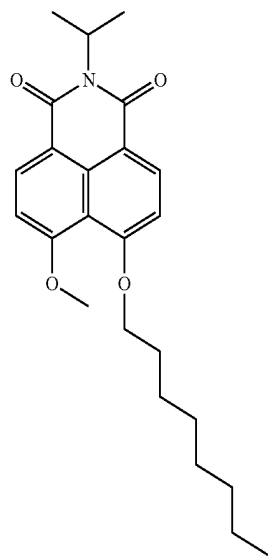

56

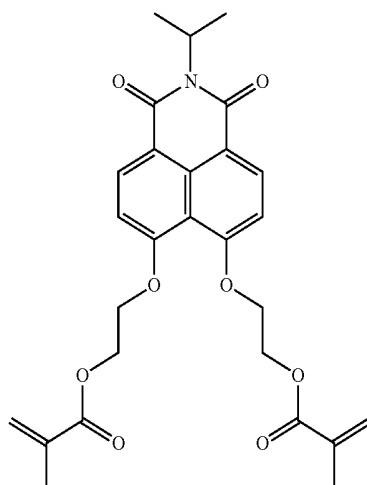

59

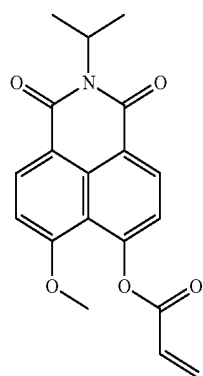

57

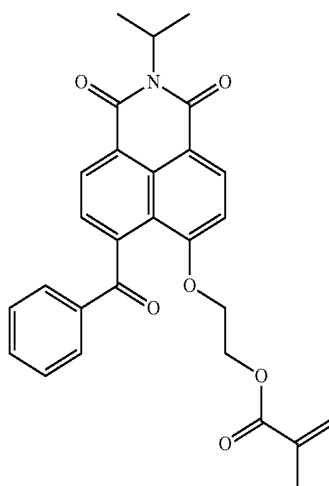

60

-continued

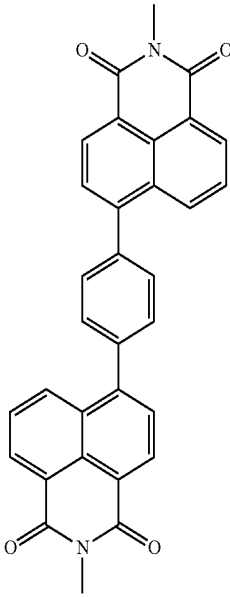

61

-continued

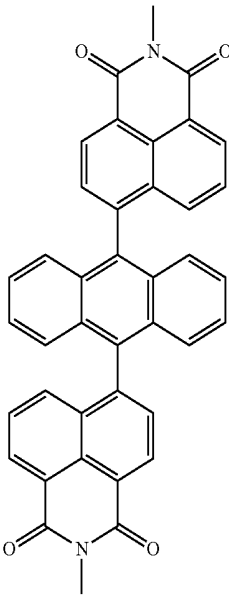

63

62

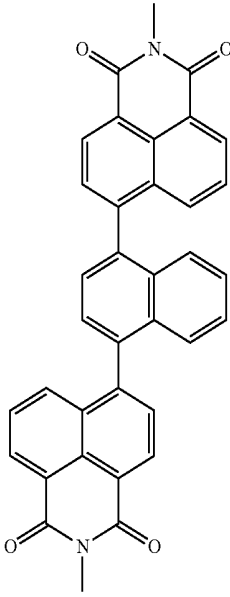

64

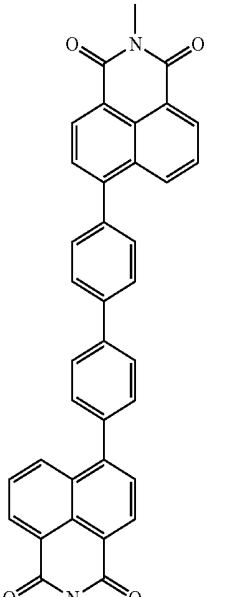

-continued

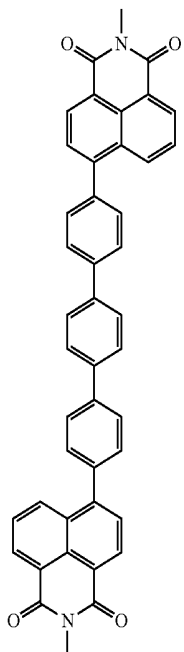

65

-continued

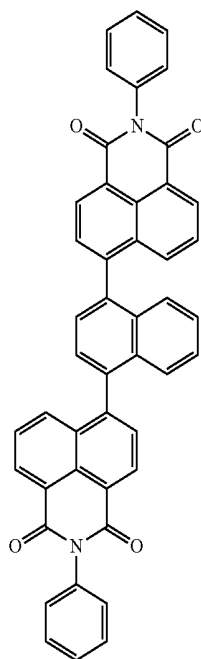

67

66

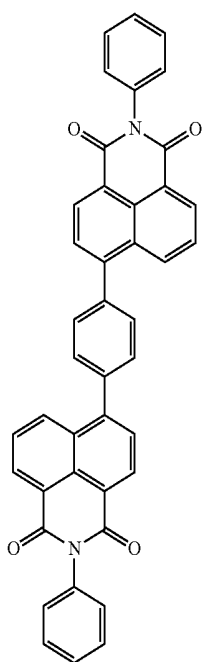

68

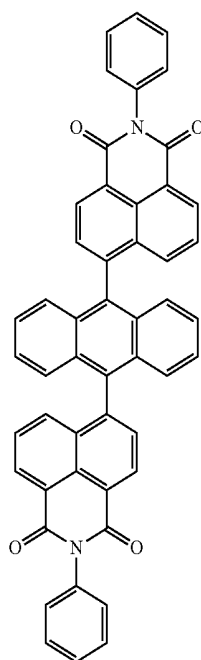

-continued

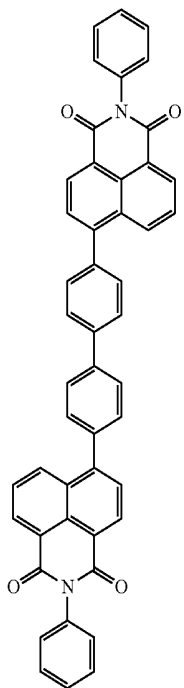

69

-continued

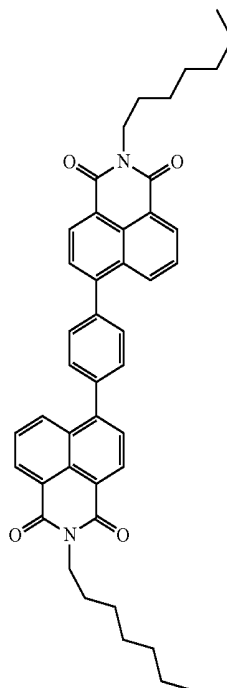

70

71

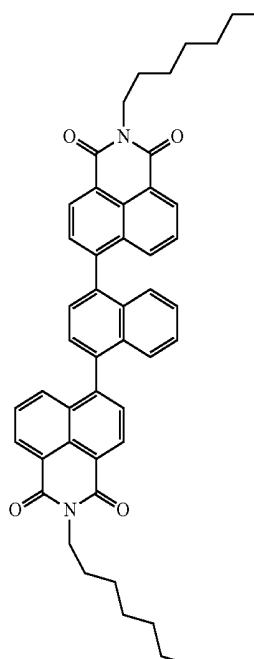
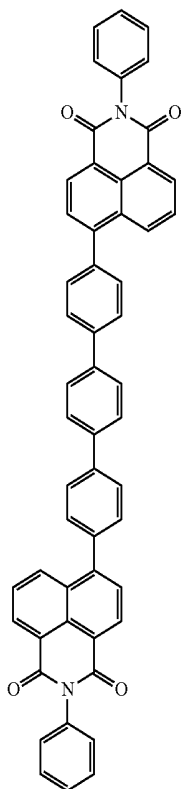

72

-continued

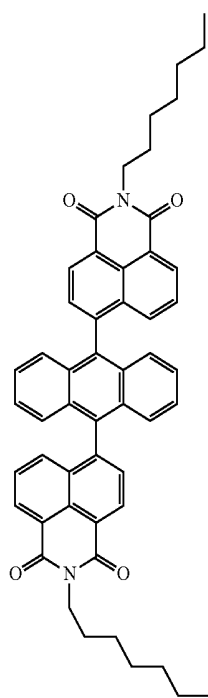

73

-continued

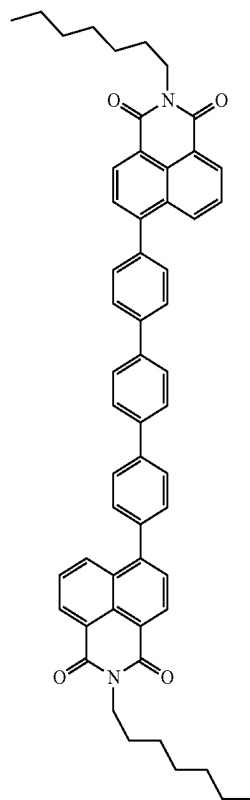

75

74

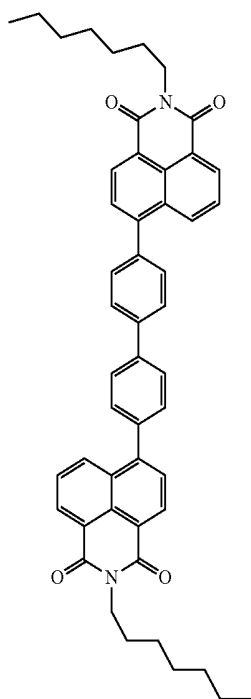

76

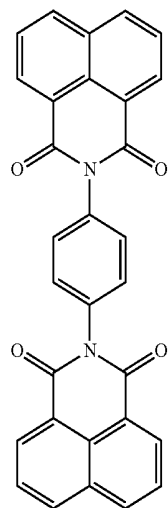

-continued

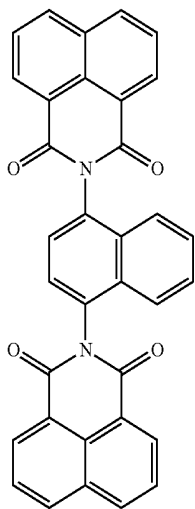

77

-continued

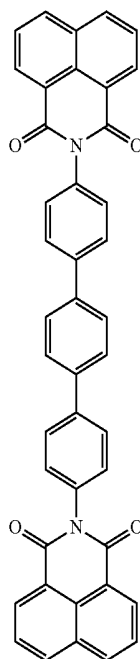

79

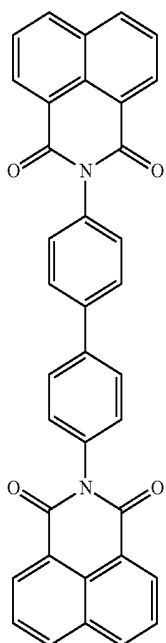

78

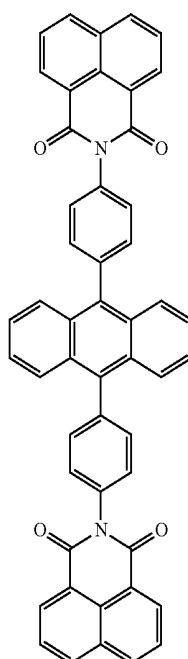

80

-continued

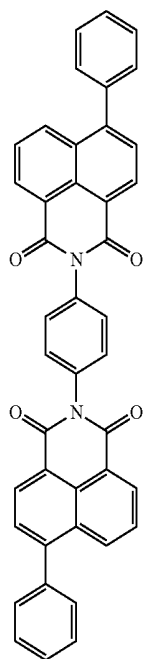

81

-continued

83

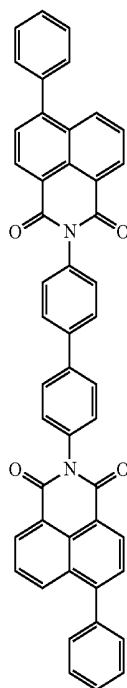

82

84

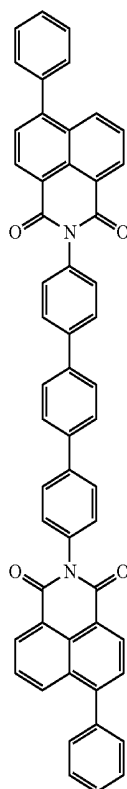
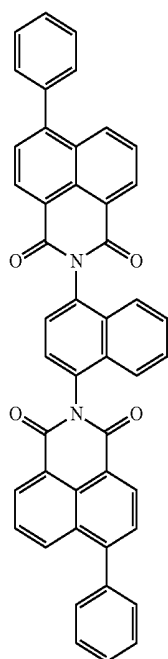

-continued

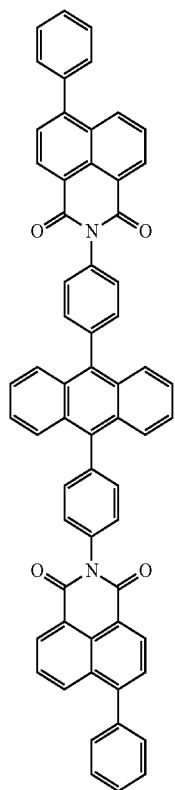

85

-continued

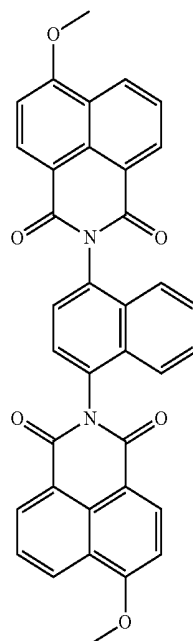

87

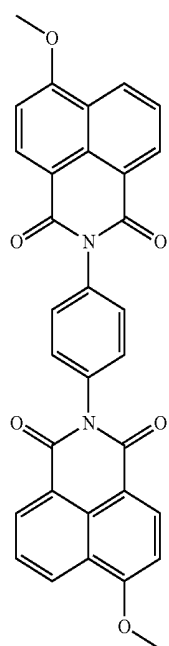

86

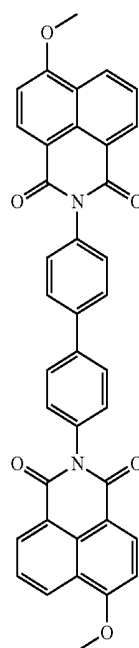

88

-continued

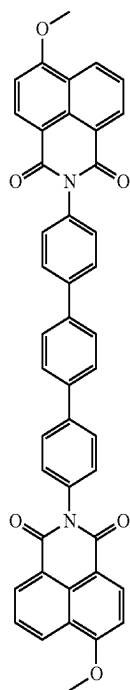

89

-continued

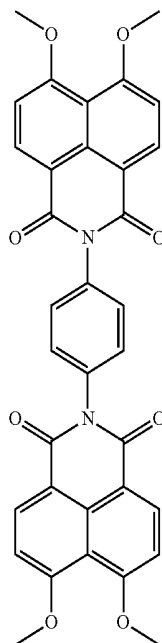

91

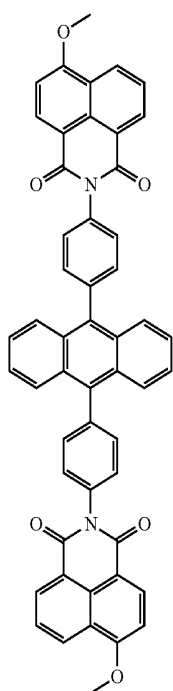

90

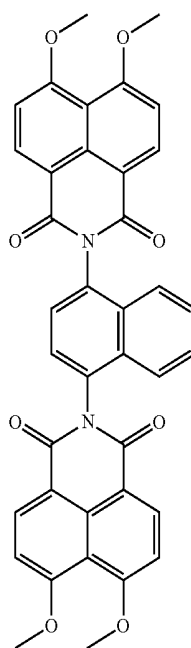

92

-continued

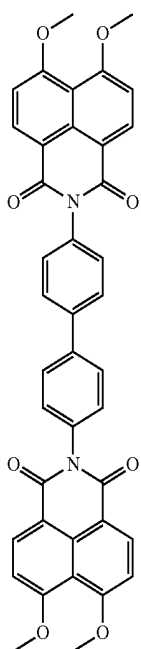

93

-continued

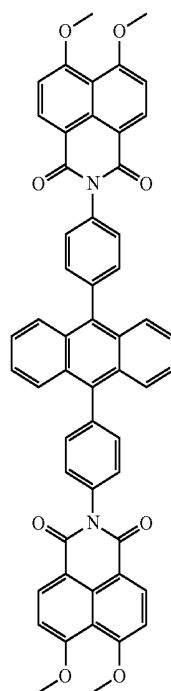

95

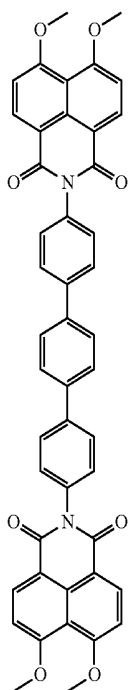

94

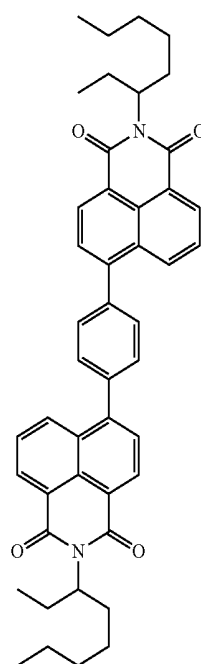

96

-continued

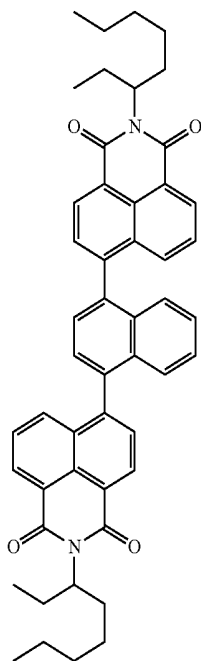

97

-continued

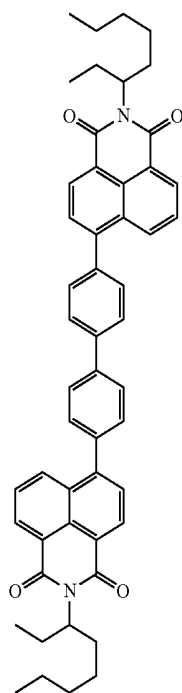

99

98

100

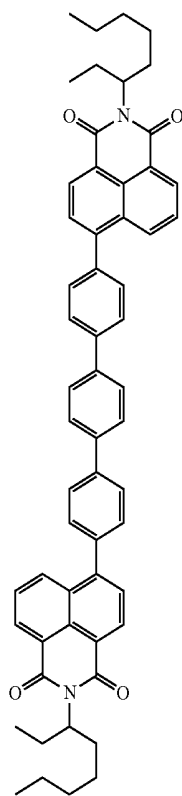
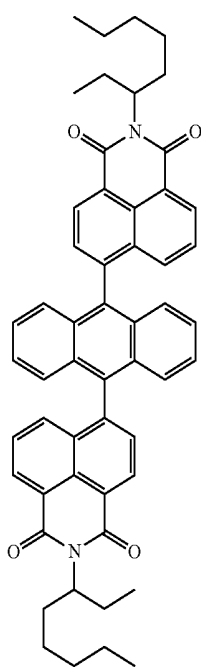

-continued

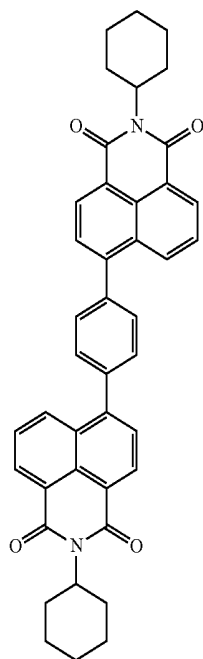

101

-continued

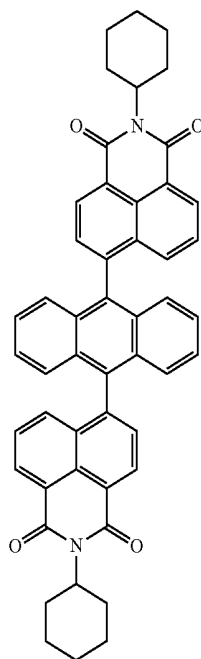

103

102

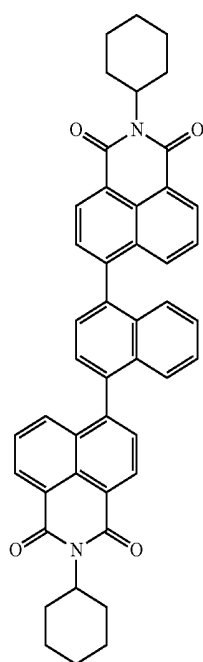

104

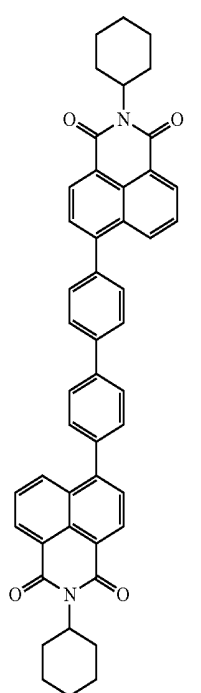

105

-continued

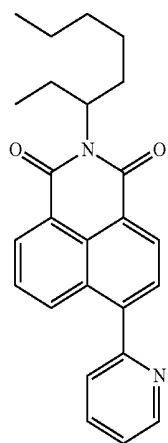
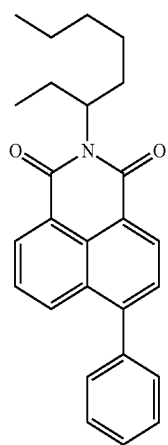
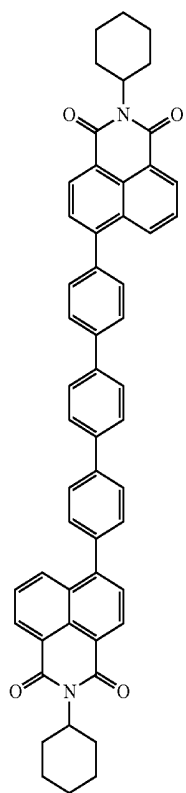

-continued

105

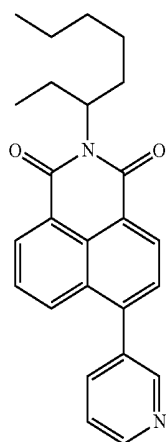

108

106

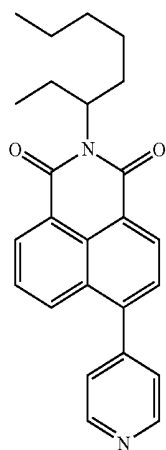

109

107

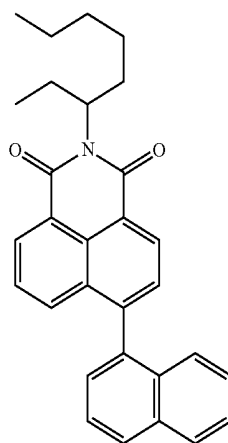

110

-continued

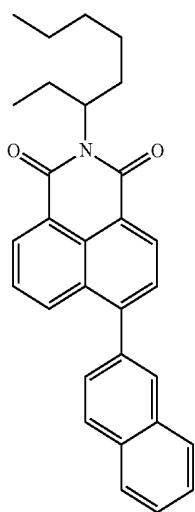

111

-continued

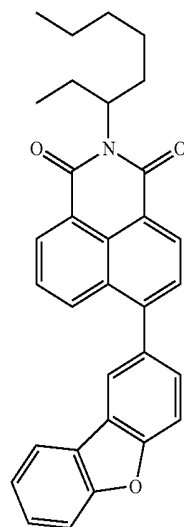

114

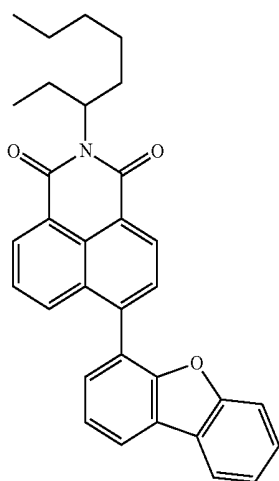

112

115

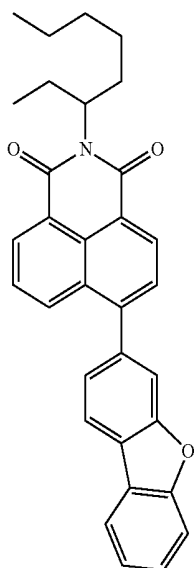
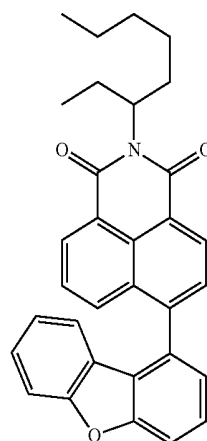

113

116

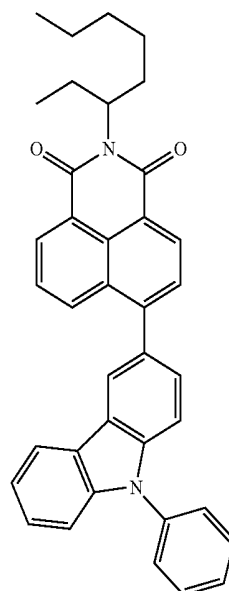

-continued

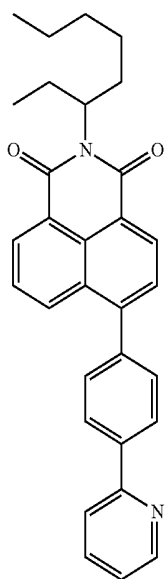

117

-continued

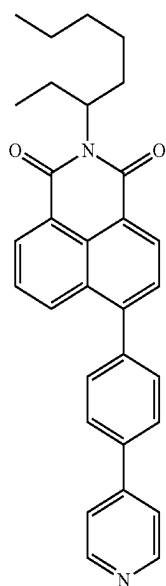

119

118

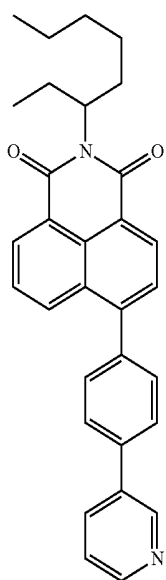

120

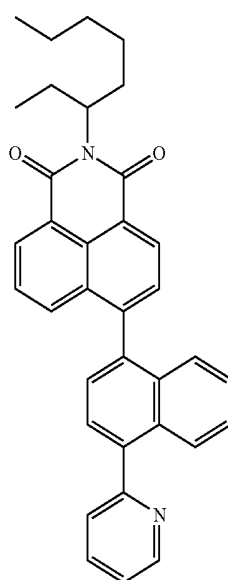

-continued

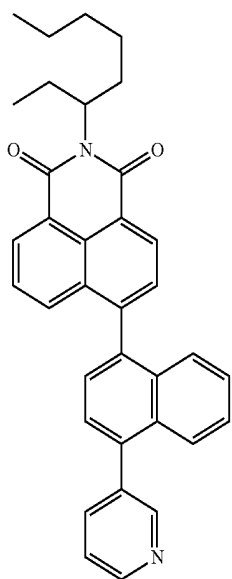

121

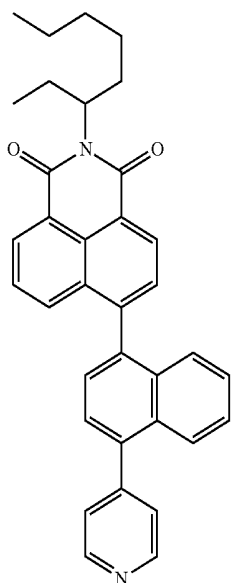

122

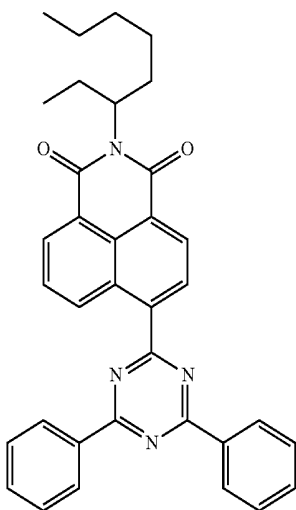

123

-continued

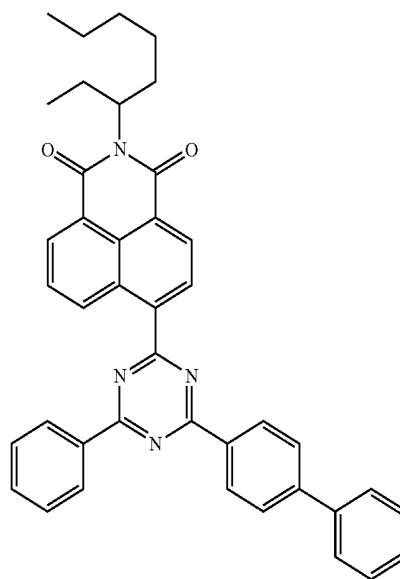

124

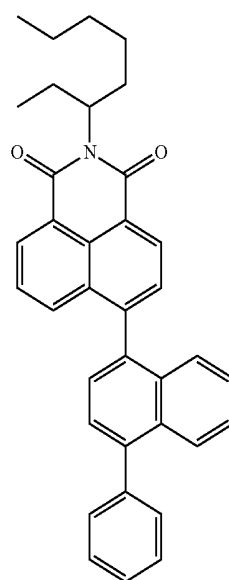

125

-continued

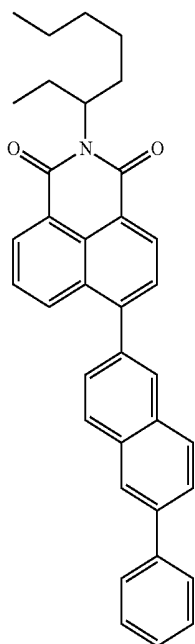

126

-continued

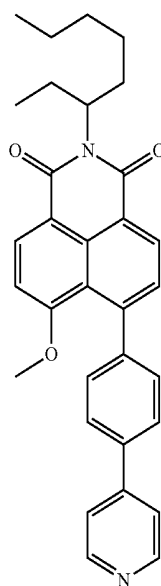

129

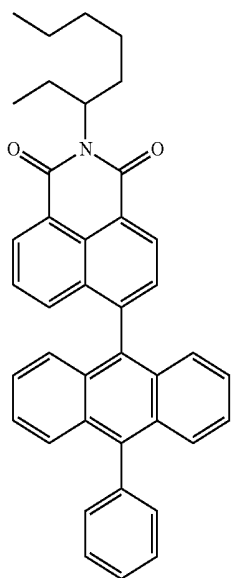

127

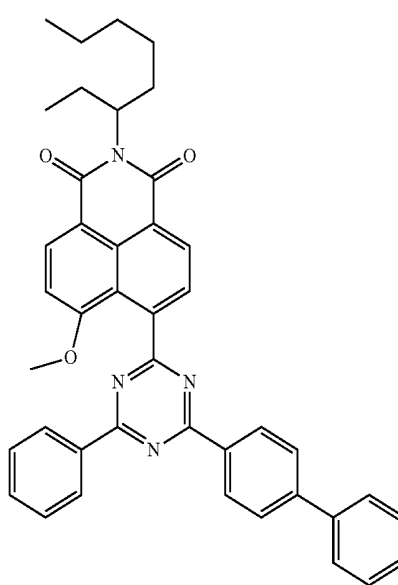

130

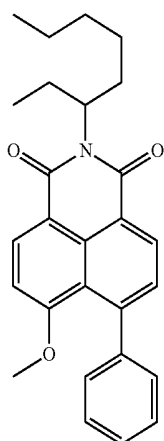

128

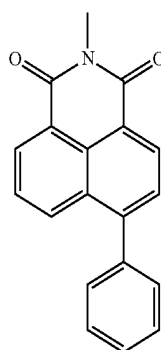

131

110

-continued

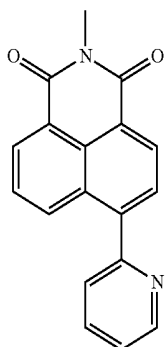

132

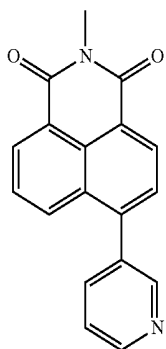

133

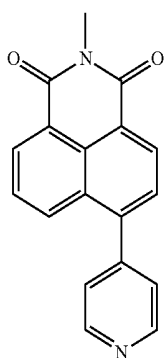

134

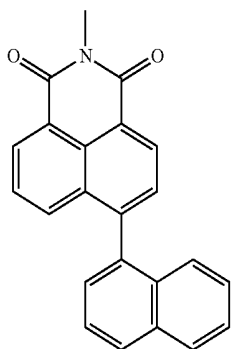

135

-continued

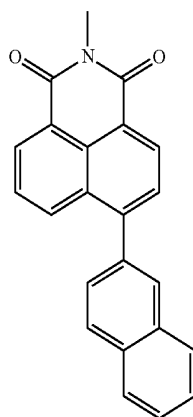

136

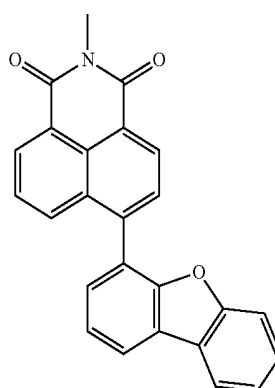

137

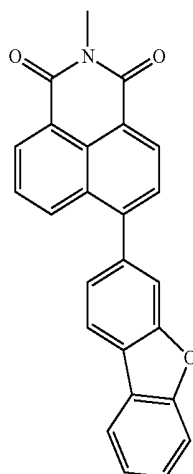

138

-continued

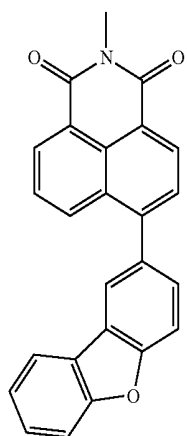

139

-continued

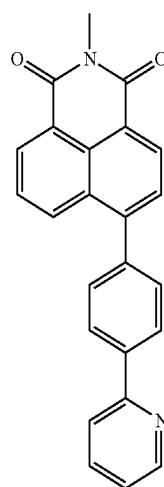

142

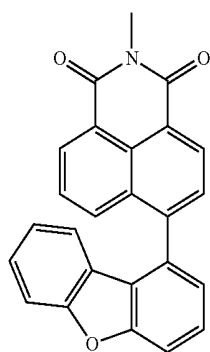

140

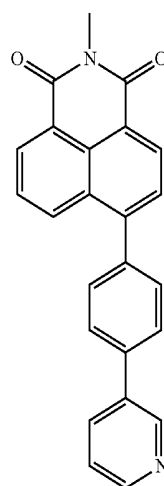

143

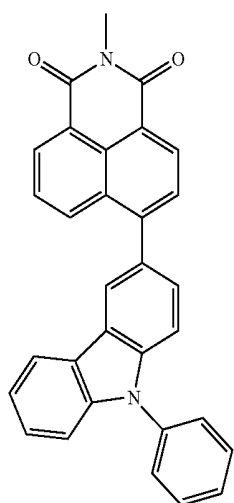

141

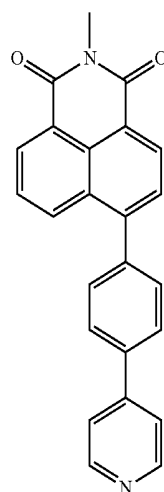

144

-continued

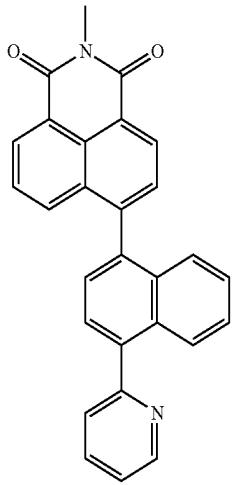

145

-continued

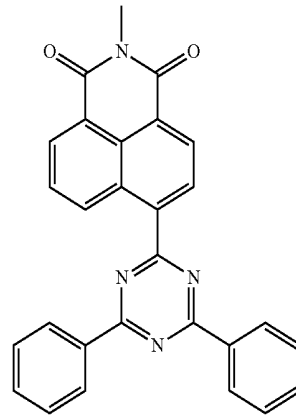

148

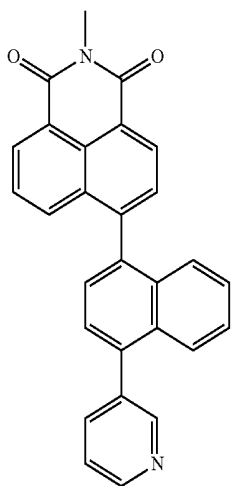

146

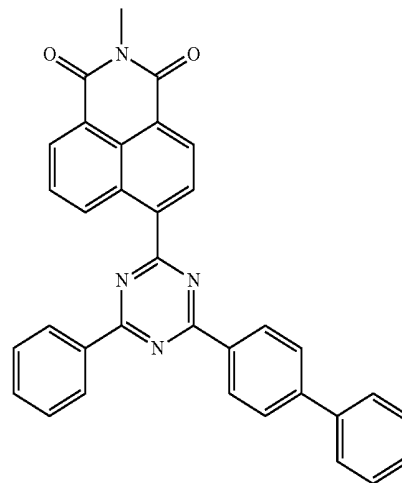

149

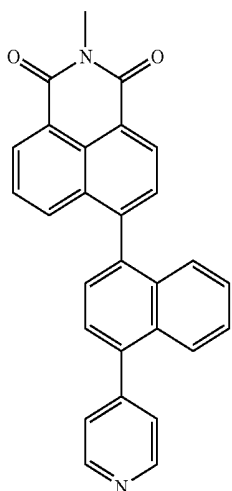

147

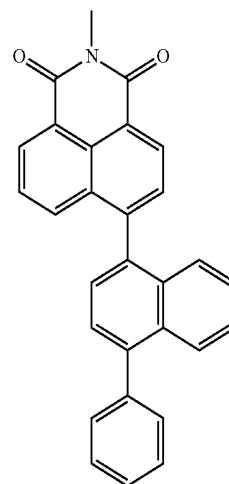

150

-continued

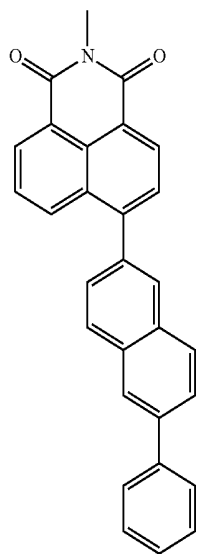

151

-continued

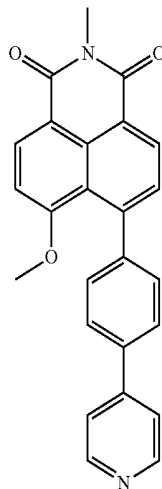

154

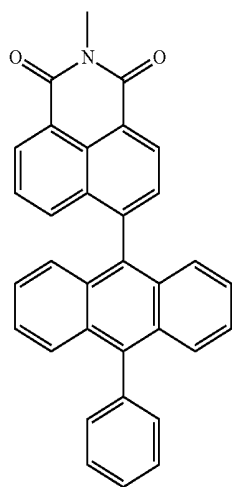

152

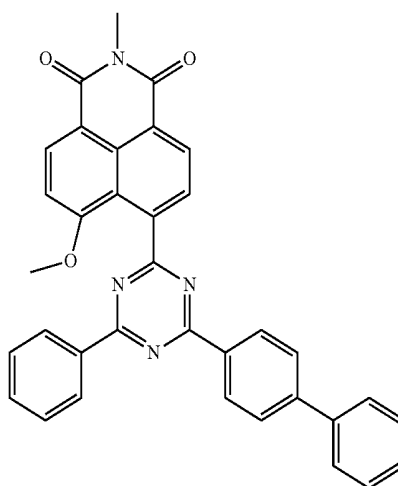

155

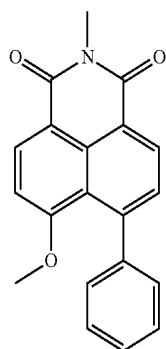

153

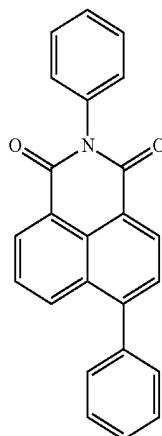

156

-continued

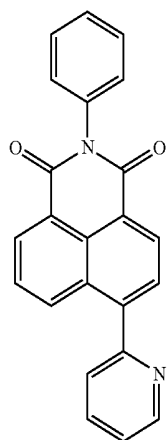

157

-continued

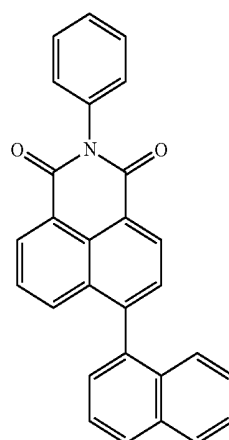

160

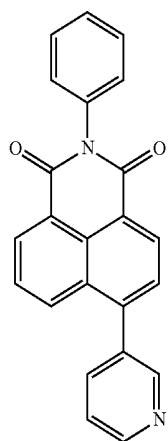

158

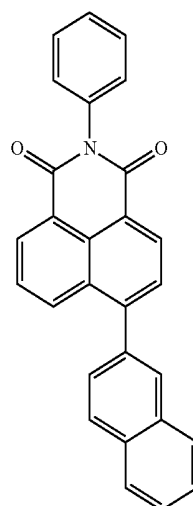

161

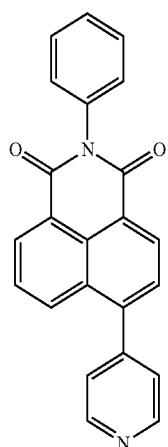

159

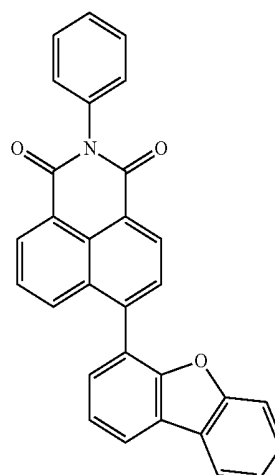

162

-continued

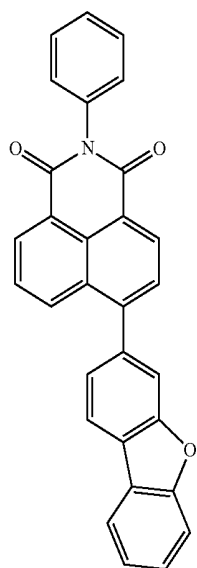

163

-continued

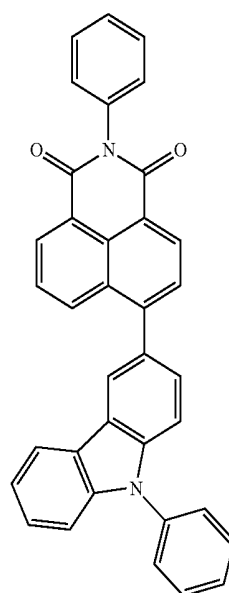

166

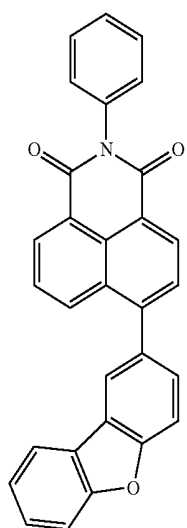

164

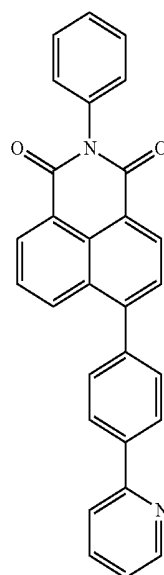

167

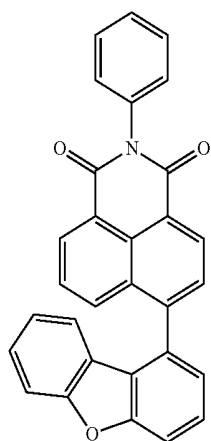

165

-continued

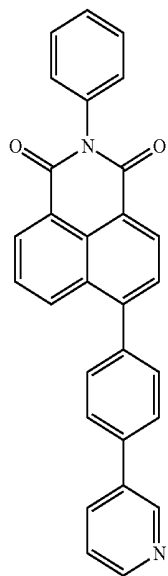

168

-continued

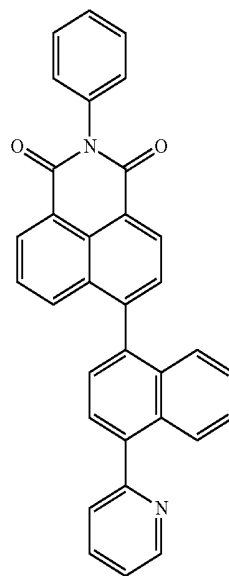

170

169

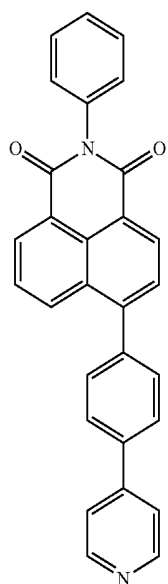

171

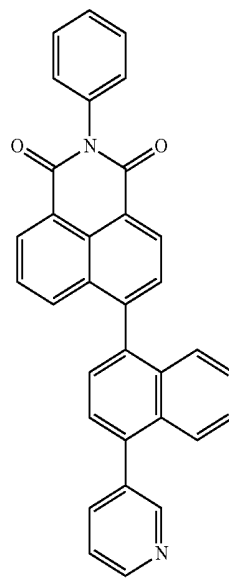

-continued

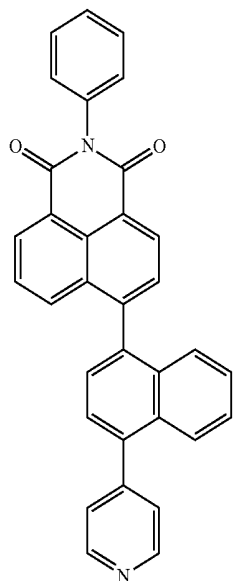

172

-continued

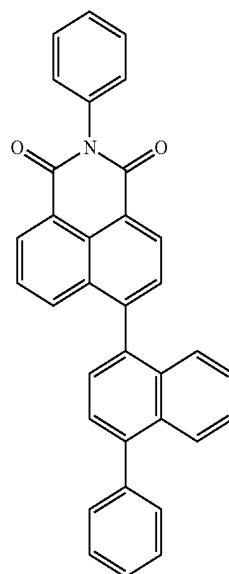

175

173

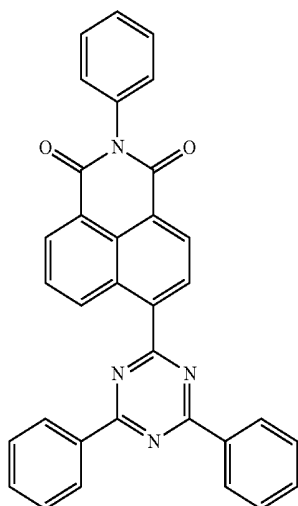

174

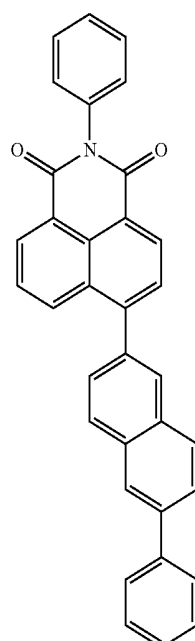
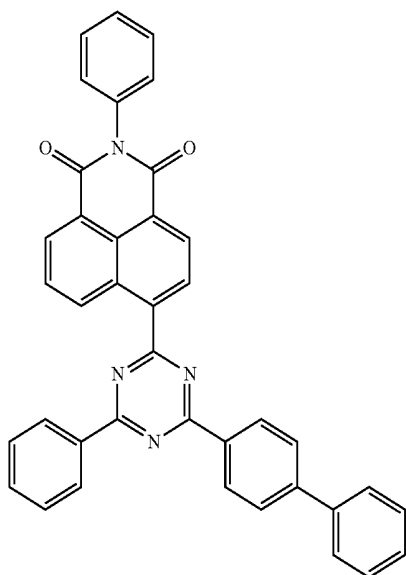

176

-continued

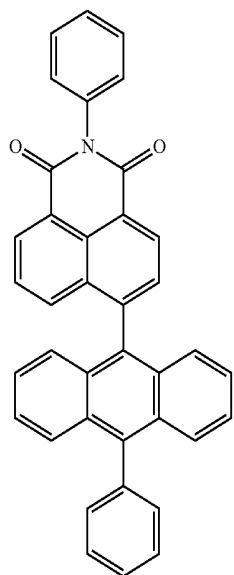

177

-continued

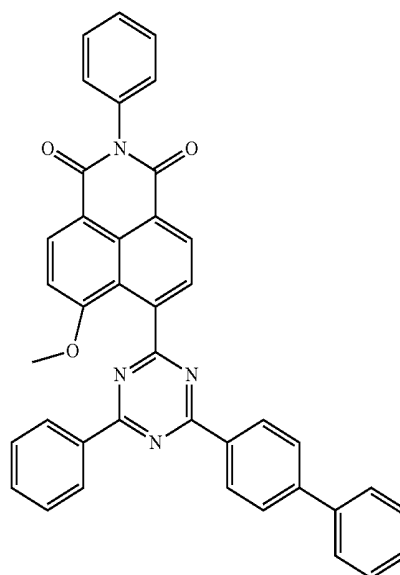

180

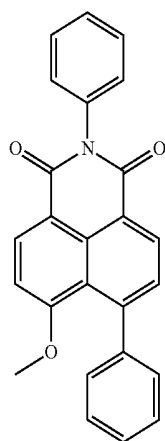

178

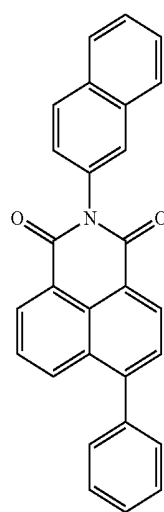

181

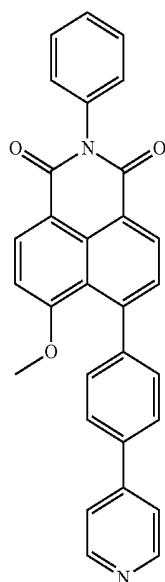

179

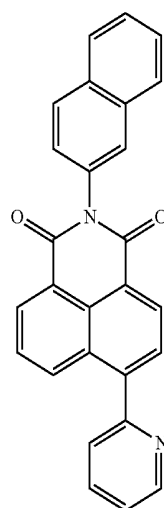

182

-continued

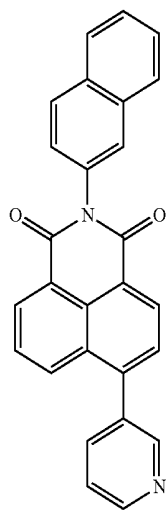

183

-continued

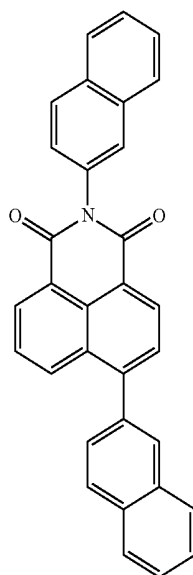

186

184

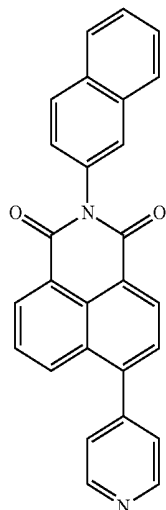

187

185

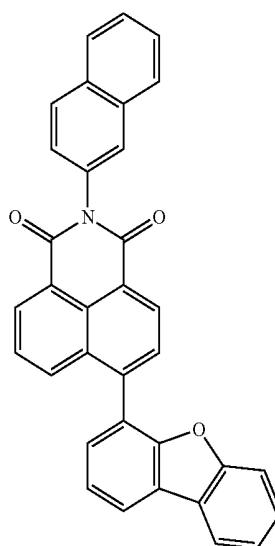
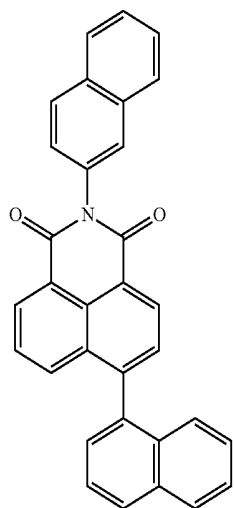

-continued

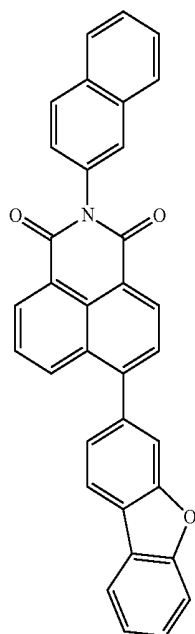

188

-continued

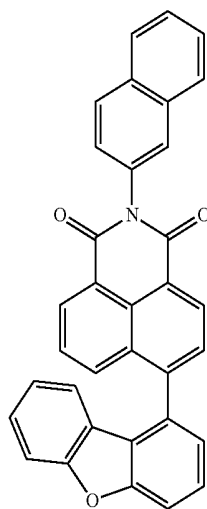

190

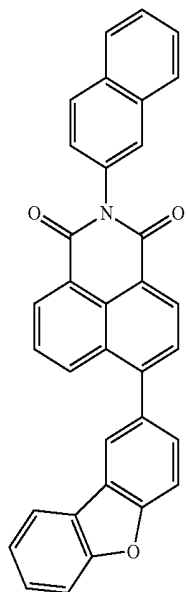

189

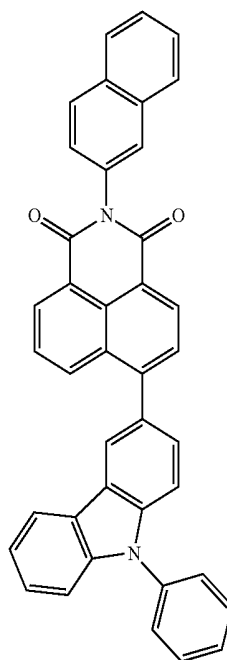

191

-continued

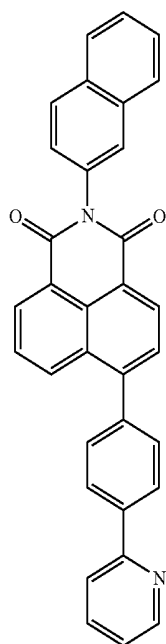

192

-continued

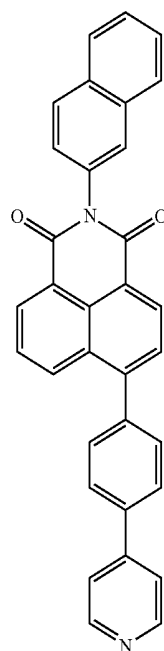

194

193

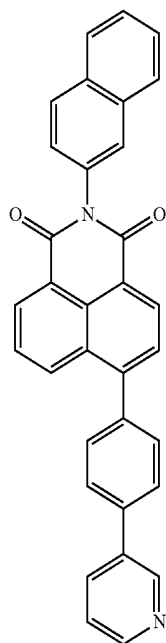

195

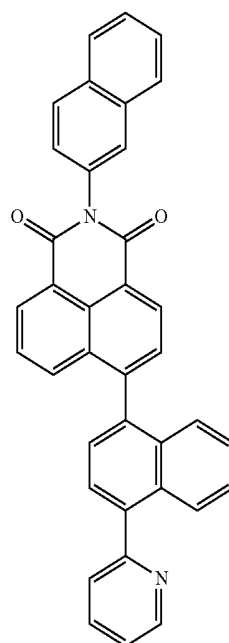

-continued

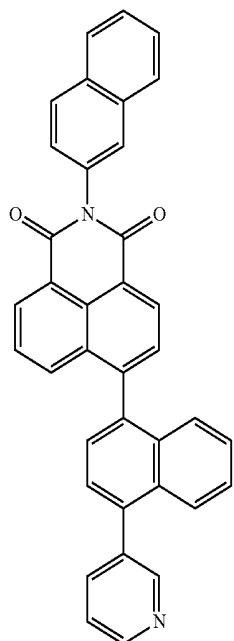

196

-continued

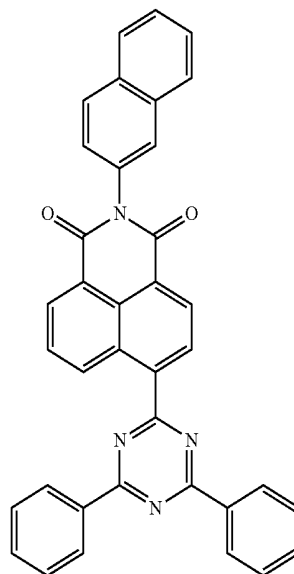

198

197

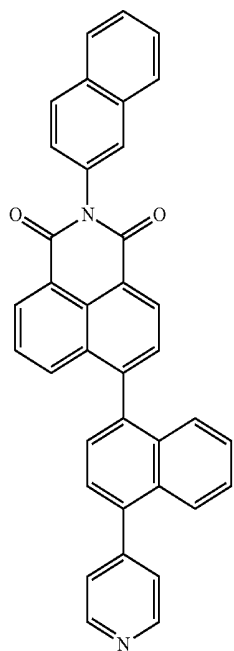

199

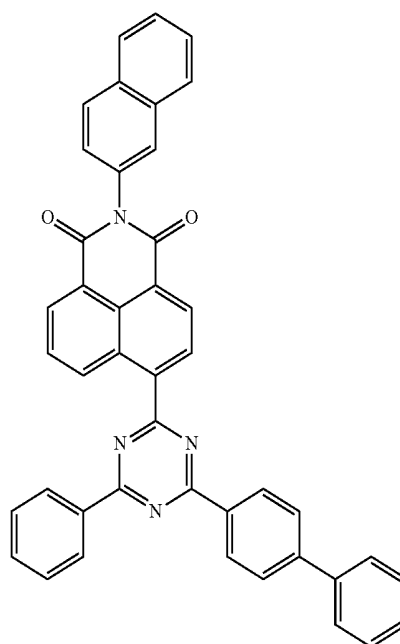

-continued

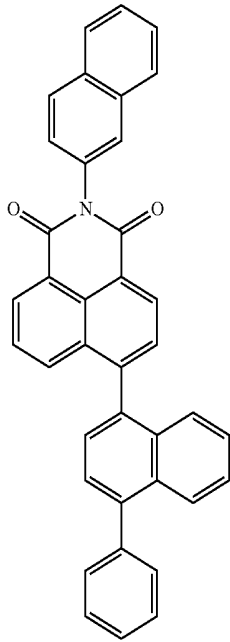

200

-continued

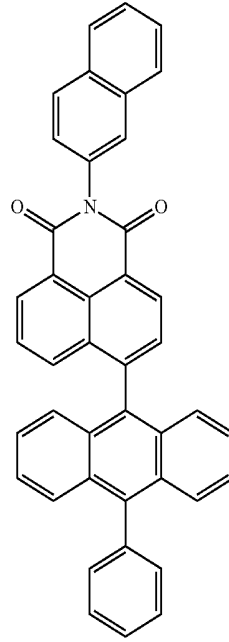

202

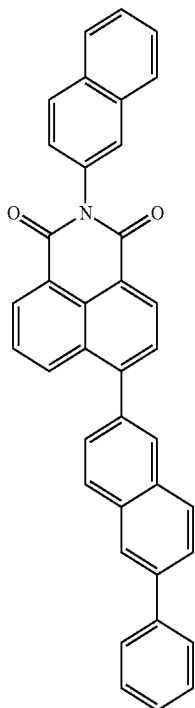

201

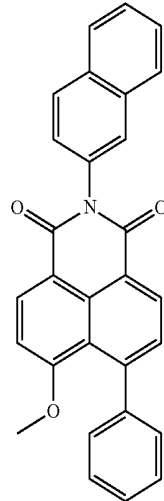

203

-continued

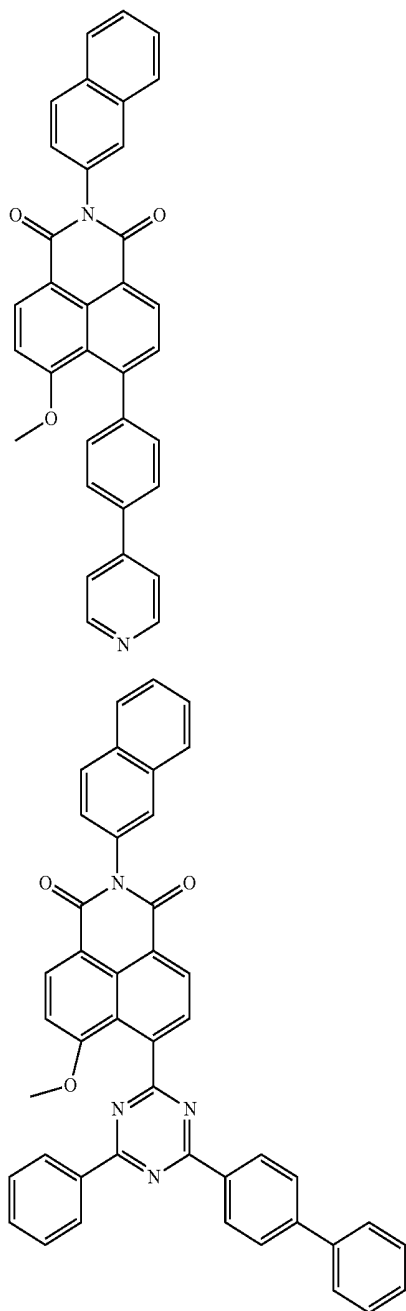

11. The organic light-emitting display apparatus of claim 1, wherein

the first compound is configured to absorb light having a wavelength of about 400 nm to about 410 nm.

12. The organic light-emitting display apparatus of claim 1, wherein

the encapsulation unit further comprises a second compound different from the first compound, and a wavelength range of light absorbed by the first compound is different from a wavelength range of light absorbed by the second compound.

13. The organic light-emitting display apparatus of claim 1, wherein

204

the encapsulation unit further comprises a third compound different from the first compound, and

the first compound is dispersed in the third compound.

14. The organic light-emitting display apparatus of claim 13, wherein

the first compound is cross-linked to the third compound.

15. The organic light-emitting display apparatus of claim 1, wherein

the encapsulation unit further comprises a metal, a metal halide, a metal nitride, a metal oxide, a metal oxynitride, a silicon nitride, a silicon oxide, and/or a silicon oxynitride.

16. The organic light-emitting display apparatus of claim 1, wherein

the encapsulation unit comprises at least one organic film and at least one inorganic film, and

the at least one organic film consists of the first compound.

17. The organic light-emitting display apparatus of claim 16, wherein

the at least one inorganic film comprises at least one selected from the group consisting of a metal, a metal halide, a metal nitride, a metal oxide, a metal oxynitride, a silicon nitride, a silicon oxide, and a silicon oxynitride.

205

18. The organic light-emitting display apparatus of claim 16, wherein

the at least one organic film comprises a first organic film, the at least one inorganic film comprises a first inorganic film, and

the first organic film is between the organic light-emitting device and the first inorganic film.

19. The organic light-emitting display apparatus of claim 16, wherein

the at least one organic film comprises a first organic film, the at least one inorganic film comprises a first inorganic film, and

the first inorganic film is between the organic light-emitting device and the first organic film.

20. An organic light-emitting display apparatus comprising:

a substrate;

an organic emission unit on the substrate and comprising a plurality of organic light-emitting devices; and

an encapsulation unit on the organic emission unit and configured to seal the organic emission unit,

wherein the encapsulation unit comprises a first compound represented by Formula 1:

Formula 1



Formula 201

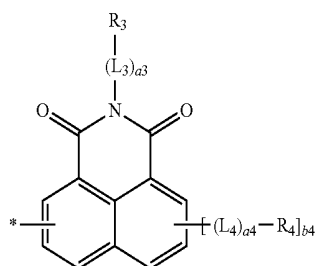

-continued

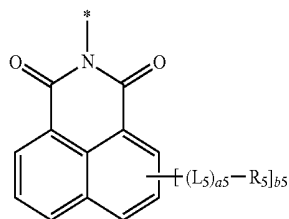

Formula 202

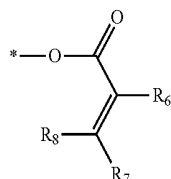

Formula 2-3

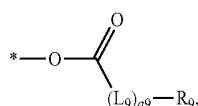

Formula 2-4

wherein, in Formulae 1 and 2-1 to 2-4,

Ar₁ is a C₅-C₆₀ carbocyclic group or a C₂-C₃₀ heterocyclic group,

c1 is 0 or 1,

L₁ to L₅ and L₉ are each independently selected from *—N(R₁₁)—*, *—B(R₁₁)—*, *—P(R₁₁)—*, *—Si(R₁₁)(R₁₂)—*, *—S—*, *—O—*, *—Se—*, *—C(=O)—*, *—S(=O)—*, *—S(=O)₂—*, *—C(R₁₁)=*, *—C(=S)—*, a substituted or unsubstituted C₁-C₆₀ alkylene group, a substituted or unsubstituted C₂-C₆₀ alkenylene group, a substituted or unsubstituted C₂-C₆₀ alkynylene group, a substituted or unsubstituted C₃-C₁₀ cycloalkylene group, a substituted or unsubstituted C₁-C₁₀ heterocycloalkylene group, a substituted or unsubstituted C₃-C₁₀ cycloalkenylene group, a substituted or unsubstituted heterocycloalkenylene group, a substituted or unsubstituted C₆-C₆₀ arylene group, a substituted or unsubstituted C₁-C₆₀ heteroarylene group, a substituted or unsubstituted divalent non-aromatic condensed polycyclic group, and a substituted or unsubstituted divalent non-aromatic condensed heteropolycyclic group,

a1 to a5 and a9 are each independently an integer from 0 to 10,

R₁ is a group represented by Formula 2-1 or a group represented by Formula 2-2,

R₂ to R₅ are each independently selected from a group represented by Formula 2-3, a group represented by Formula 2-4, hydrogen, deuterium, —F, —Cl, —Br, —I, a hydroxyl group, a cyano group, a nitro group, an amidino group, a hydrazino group, a hydrazono group, a substituted or unsubstituted C₁-C₆₀ alkyl group, a substituted or unsubstituted C₂-C₆₀ alkenyl group, a substituted or unsubstituted C₂-C₆₀ alkynyl group, a substituted or unsubstituted C₁-C₆₀ alkoxy group, a substituted or unsubstituted C₃-C₆₀ cycloalkoxy group, a substituted or unsubstituted C₃-C₁₀ cycloalkyl group, a substituted or unsubstituted C₁-C₁₀ heterocycloalkyl group, a substituted or unsubstituted C₃-C₁₀ cycloalkenyl group, a substituted or unsubstituted C₁-C₁₀ heterocycloalkenyl group, a substituted or unsubstituted

C₆-C₆₀ aryl group, a substituted or unsubstituted C₆-C₆₀ aryloxy group, a substituted or unsubstituted C₆-C₆₀ arylthio group, a substituted or unsubstituted C₁-C₆₀ heteroaryl group, a substituted or unsubstituted monovalent non-aromatic condensed polycyclic group, a substituted or unsubstituted monovalent non-aromatic condensed heteropolycyclic group, Si(Q₁)(Q₂)(Q₃), —N(Q₁)(Q₂), —B(Q₁)(Q₂), —C(=O)(Q₁), —S(=O)₂(Q₁), and —P(=O)(Q₁)(Q₂),

R₆ to R₉, R₁₁, and R₁₂ are each independently selected from hydrogen, deuterium, —F, —Cl, —Br, —I, a hydroxyl group, a cyano group, a nitro group, an amidino group, a hydrazino group, a hydrazono group, a substituted or unsubstituted C₁-C₆₀ alkyl group, a substituted or unsubstituted C₂-C₆₀ alkenyl group, a substituted or unsubstituted C₂-C₆₀ alkynyl group, a substituted or unsubstituted C₁-C₆₀ alkoxy group, a substituted or unsubstituted C₃-C₆₀ cycloalkoxy group, a substituted or unsubstituted C₃-C₁₀ cycloalkyl group, a substituted or unsubstituted C₁-C₁₀ heterocycloalkyl group, a substituted or unsubstituted C₃-C₁₀ cycloalkenyl group, a substituted or unsubstituted C₁-C₁₀ heterocycloalkenyl group, a substituted or unsubstituted C₆-C₆₀ aryl group, a substituted or unsubstituted C₆-C₆₀ aryloxy group, a substituted or unsubstituted C₆-C₆₀ arylthio group, a substituted or unsubstituted C₁-C₆₀ heteroaryl group, a substituted or unsubstituted monovalent non-aromatic condensed polycyclic group, a substituted or unsubstituted monovalent non-aromatic condensed heteropolycyclic group, Si(Q₄)(Q₅)(Q₆), —N(Q₄)(Q₅), —B(Q₄)(Q₅), —C(=O)(Q₄), —S(=O)₂(Q₄), and —P(=O)(Q₄)(Q₅),

b1 is an integer from 1 to 10, wherein, when b1 is two or more, two or more *(L₁)_{a1}-R₁(s) are identical to or different from each other,

b2 is an integer from 1 to 10, wherein, when b2 is two or more, two or more *(L₂)_{a2}-R₂(s) are identical to or different from each other,

b4 is an integer from 0 to 5, wherein, when b4 is two or more, two or more *(L₄)_{a4}-R₄(s) are identical to or different from each other,

b5 is an integer from 0 to 6, wherein, when b5 is two or more, two or more *(L₅)_{a5}-R₅(s) are identical to or different from each other,

at least one substituent of the substituted C₁-C₆₀ alkylene group, the substituted C₂-C₆₀ alkenylene group, the substituted C₂-C₆₀ alkynylene group, the substituted C₃-C₁₀ cycloalkylene group, the substituted C₁-C₁₀ heterocycloalkylene group, the substituted C₃-C₁₀ cycloalkenylene group, the substituted C₁-C₁₀ heterocycloalkenylene group, the substituted C₆-C₆₀ arylene group, the substituted C₁-C₆₀ heteroarylene group, the substituted divalent non-aromatic condensed polycyclic group, the substituted divalent non-aromatic condensed heteropolycyclic group, the substituted C₁-C₆₀ alkyl group, the substituted C₂-C₆₀ alkenyl group, the substituted C₂-C₆₀ alkynyl group, the substituted C₁-C₆₀ alkoxy group, the substituted C₃-C₆₀ cycloalkoxy group, the substituted C₃-C₁₀ cycloalkyl group, the substituted C₁-C₁₀ heterocycloalkyl group, the substituted C₃-C₁₀ cycloalkenyl group, the substituted C₁-C₁₀ heterocycloalkenyl group, the substituted C₆-C₆₀ aryl group, the substituted C₆-C₆₀ aryloxy group, the substituted C₆-C₆₀ arylthio group, the sub-

- stituted C₁-C₆₀ heteroaryl group, the substituted monovalent non-aromatic condensed polycyclic group, and the substituted monovalent non-aromatic condensed heteropolycyclic group is selected from:
- deuterium, —F, —Cl, —Br, —I, a hydroxyl group, a cyano group, a nitro group, an amidino group, a hydrazino group, a hydrazono group, a C₁-C₆₀ alkyl group, a C₂-C₆₀ alkenyl group, a C₂-C₆₀ alkynyl group, a C₁-C₆₀ alkoxy group, and a C₃-C₆₀ cycloalkoxy group;
- a C₁-C₆₀ alkyl group, a C₂-C₆₀ alkenyl group, a C₂-C₆₀ alkynyl group, a C₁-C₆₀ alkoxy group, and a C₃-C₆₀ cycloalkoxy group, each substituted with at least one selected from deuterium, —F, —Cl, —Br, —I, a hydroxyl group, a cyano group, a nitro group, an amidino group, a hydrazino group, a hydrazono group, a C₃-C₁₀ cycloalkyl group, a C₁-C₁₀ heterocycloalkyl group, a C₃-C₁₀ cycloalkenyl group, a C₁-C₁₀ heterocycloalkenyl group, a C₆-C₆₀ aryl group, a C₆-C₆₀ aryloxy group, a C₆-C₆₀ arylthio group, a C₁-C₆₀ heteroaryl group, a monovalent non-aromatic condensed polycyclic group, a monovalent non-aromatic condensed heteropolycyclic group, —Si(Q₁₁)(Q₁₂)(Q₁₃), —N(Q₁₁)(Q₁₂), —B(Q₁₁)(Q₁₂), —C(=O)(Q₁₁), —S(=O)₂(Q₁₁), and —P(=O)(Q₁₁)(Q₁₂);
- a C₃-C₁₀ cycloalkyl group, a C₁-C₁₀ heterocycloalkyl group, a C₃-C₁₀ cycloalkenyl group, a C₁-C₁₀ heterocycloalkenyl group, a C₆-C₆₀ aryl group, a C₆-C₆₀ aryloxy group, a C₆-C₆₀ arylthio group, a C₁-C₆₀ heteroaryl group, a monovalent non-aromatic condensed polycyclic group, a monovalent non-aromatic condensed heteropolycyclic group, a biphenyl group, and a terphenyl group;
- a C₃-C₁₀ cycloalkyl group, a C₁-C₁₀ heterocycloalkyl group, a C₃-C₁₀ cycloalkenyl group, a C₁-C₁₀ heterocycloalkenyl group, a C₆-C₆₀ aryl group, a C₆-C₆₀ aryloxy group, a C₆-C₆₀ arylthio group, a C₁-C₆₀ heteroaryl group, a monovalent non-aromatic condensed polycyclic group, and a monovalent non-aromatic condensed heteropolycyclic group, each substituted with at least one selected from deuterium, —F, —Cl, —Br, —I, a hydroxyl group, a cyano group, a nitro group, an amidino group, a hydrazino group, a hydrazono group, a C₇-C₁₀ heterocycloalkenyl group, a C₆-C₆₀ aryl group, a C₆-C₆₀ aryloxy group, a C₆-C₆₀ arylthio group, a C₁-C₆₀ heteroaryl group, a monovalent non-aromatic condensed polycyclic group, a monovalent non-aromatic condensed heteropolycyclic group, —Si(Q₂₁)(Q₂₂)(Q₂₃), —N(Q₂₁)(Q₂₂), —B(Q₂₁)(Q₂₂), —C(=O)(Q₂₁), —S(=O)₂(Q₂₁), and —P(=O)(Q₂₁)(Q₂₂), and —Si(Q₃₁)(Q₃₂)(Q₃₃), —N(Q₃₁)(Q₃₂), —B(Q₃₁)(Q₃₂), —C(=O)(Q₃₁), —S(=O)₂(Q₃₁), and —P(=O)(Q₃₁)(Q₃₂),
- Q₁ to Q₆, Q₁₁ to Q₁₃, Q₂₁ to Q₂₃, and Q₃₁ to Q₃₃ are each independently selected from hydrogen, deuterium, —F, —Cl, —Br, —I, a hydroxyl group, a cyano group, a nitro group, an amidino group, a hydrazino group, a hydrazono group, a C₁-C₆₀ alkyl group, a C₂-C₆₀ alkenyl group, a C₂-C₆₀ alkynyl group, a C₁-C₆₀ alkoxy group, a C₃-C₆₀ cycloalkoxy group, a C₃-C₁₀ cycloalkyl group, a C₁-C₁₀ heterocycloalkyl group, a C₃-C₁₀ cycloalkenyl group, a C₁-C₁₀ heterocycloalkenyl group, a C₆-C₆₀ aryl group, a C₆-C₆₀ aryl group substituted with a C₁-C₆₀ alkyl group, a C₆-C₆₀ aryl group substituted with a C₆-C₆₀ aryl group, a terphenyl group, a C₁-C₆₀ heteroaryl group, a C₁-C₆₀ heteroaryl group substituted with a C₁-C₆₀ alkyl group, a C₁-C₆₀ heteroaryl group substituted with a C₆-C₆₀ aryl group, a monovalent non-aromatic condensed polycyclic group, a monovalent non-aromatic condensed heteropolycyclic group, a biphenyl group, and a terphenyl group, and
- * and *' each indicate a binding site to a neighboring atom.

* * * * *

专利名称(译)	有机发光显示装置		
公开(公告)号	US20190051860A1	公开(公告)日	2019-02-14
申请号	US15/973289	申请日	2018-05-07
[标]申请(专利权)人(译)	三星显示有限公司		
申请(专利权)人(译)	三星DISPLAY CO. , LTD.		
当前申请(专利权)人(译)	三星DISPLAY CO. , LTD.		
[标]发明人	JEONG EUNJAE KIM YOUNGKOOK KIM YOCHAN KIM ESU KIM JONGWOO BAEK JANGYEOL YUN WONMIN HAN SANGHYUN HWANG SEOKHWAN		
发明人	JEONG, EUNJAE KIM, YOUNGKOOK KIM, YOCHAN KIM, ESU KIM, JONGWOO BAEK, JANGYEOL YUN, WONMIN HAN, SANGHYUN HWANG, SEOKHWAN		
IPC分类号	H01L51/52 H01L27/32 H01L51/00 C07D221/14 C07D401/10		
CPC分类号	H01L51/5253 H01L27/3244 H01L27/322 H01L51/0072 H01L51/0067 C07D221/14 C07D401/10 H01L51/5237		
优先权	1020170101347 2017-08-09 KR		
其他公开文献	US10381596		
外部链接	Espacenet USPTO		

摘要(译)

一种有机发光显示装置，包括基板，设置在基板上方的有机发光装置，以及设置在有机发光装置上方并密封有机发光装置的封装单元，其中封装单元包括化合物由式1表示。[R 1 - (L 1) A1]B1 - (AR 1) C1 - [(L 2) A2 - R 2]B2。20032003公式1

